

Noise Protected Buildings

Zoran Petrović^{1,*} - Branko Radičević¹ - Zlatan Šoškić - Momir Praščević²

¹University of Kragujevac, Faculty of Mech. Engineering Kraljevo

²University of Nis, Faculty of Occupational Safety Nis

This paper presents the example of activities to protect occupants from the noise. The analysis was made in case when the boiler for heating of the building and the surrounding colony is settled in the basement of the building. As has often been the case earlier in the design of new settlements heating boilers were housed in the annex building or basement area. As the colony grow, the changes were made in the technology of heating and to increase of heating capacity. Accordingly, there came deterioration of conditions in terms of noise in apartments. In our example, we analyzed primary and secondary sources of noise and their impact on the occupants in the building. On the basis of the analysis of noise levels and insulating capabilities of the walls and ceilings the measures for noise reduction are proposed. Combined methods of active and passive noise abatement measures have been applied in phases in order to achieve a satisfactory level of noise in the most affected dwellings. The paper also presents some results, achieved improvements, derived measures of protection against noise.

Keywords: noise reduction, boilers, fan noise control

0. INTRODUCTION

1.

The solutions of eliminating high levels of noise in these cases are particularly interesting and challenging because the space is limited and there is a greater number of devices and machines that are sources of noise. In this case the engine-room is equipped with two boilers from the 4000 kW, two radial fan for a flue gas 5.5kW and 7.5kW power, the heating pump motor power 18.5kW and pressure maintenance pump motor power 0.55kW. In addition, there are also secondary sources of noise during operation. For example, due to the flow of smoke in the chimney flue pipe noise occurs, also, the noise occurs due to attenuation and air supply to the burner so that the exploitation regimes at lower noise levels appear higher.

The poor quality of mechanical structures, loosening of ties, wear elements also cause a secondary noise. Particularly important is regular and proper maintenance.

1 ANALYSIS OF NOISE SOURCES

Boiler room equipment is housed in the basement of the residential building with five floors and is used for heating not only the building it self but the entire surrounding part of the town. All equipment is allocated in three rooms. In the first-central room are located two boilers and flue gas fans, which are the main

sources of noise. In the second (left to the entrance) room there are circulation pumps for heating and in the third room is fuel (fuel oil).

The disadvantage of this layout is that the loudest devices are just below the apartments. The chimney is physically located in the center of the building so that the sound generated from the oil burning in furnace and the operating fan transfers into the building as airborne sound and the second part as structural sound. Figure 1. shows the layout of equipment and position of the nearest apartment.

Because the equipment operates together and there is an increased level of noise, intensity is measured individually for each sound source, both in the boiler room and upstairs in the hallway outside the apartments. The results of measurements are shown in Table 1.

Table 1 View the noise level in the boiler room and the floor in dB

Noise Sources	Level in boiler room	Level in the build.
Circul.pump	83	44
Boiler 1	90	43
Boiler 2	89	43
Boiler 2 + Fan2	92	49
Fan 2	89	47
Burner Nozzle	104	is set aside

* Corr. Author's Adress: Faculty of Mech. Engineering Kraljevo, Dositejeva 19, Kraljevo, Serbia, petrovic.z@mfv.rs

The results can be concluded about the impact in each of the individual sources.

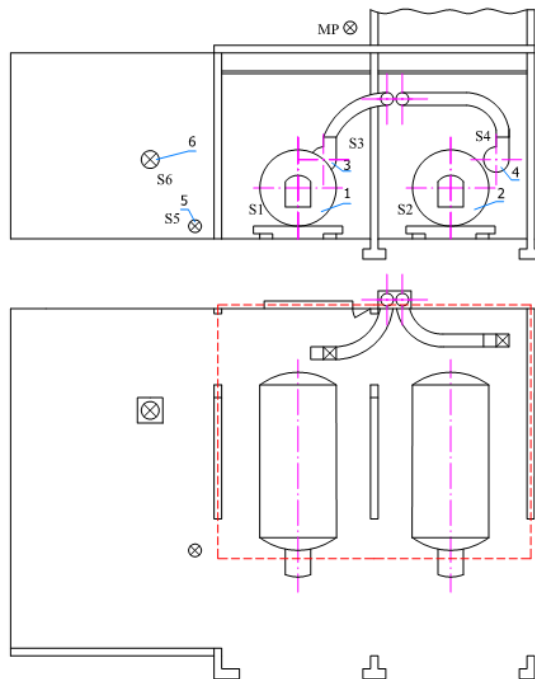

Fig.1. Layout of boiler room

1- boiler No. 1; 2 – boiler No. 2; 3 – flue gas fan (No.1); 4 - flue gas fan (No.2); 5 – pump to maintain pressure; 6 – circulation pump

Circulation pump item.6 located in room 2.(Left to the boilers room) has relatively the same effect on noise in the hallway as boilers, because it is structurally connected to the ceiling and the insulation between the room and hall is much weaker. In this case there is a transfer of airborne and structural noise. Structural noise is transmitted through the pipe and support structure.

Boilers and fans according to Table1. have a single noise level around 90dB. In case when operating both, the boiler and flue gas fan, the noise level increases from 3 to 4dB.

As the fan 2 can be switched on without activating the boiler the measured intensity noise in the boiler room is 89dB and 47dB in hallway of the building. So on the basis of Table 1. it is shown that the highest noise level was transmitted from the Fan2. to the hallway, because sum of the noise level of the boiler 2. and the fan 2 is two

decibels higher than the fan2. itself. It is clear that a fan2 is dominant noise source.

Equation (1) shows that the influence of the boiler to the level of noise in the hallway is:

$$L = 10 \cdot \log \left(10^{L_t/10} - 10^{L_f/10} \right) = 45 \text{ dBA} \quad (1)$$

where: $L_t = 49 \text{ dBA}$ - total level of noise
 $L_f = 47 \text{ dBA}$ -fan noise

The importance of eliminating noise from the fan thus becomes the most important.

Measurements in an apartment above the boiler room which were obtained by an equivalent noise level values are presented in Tab.2. It occurs when boilers operate individually and together. In both cases the circulation pump was turned on.

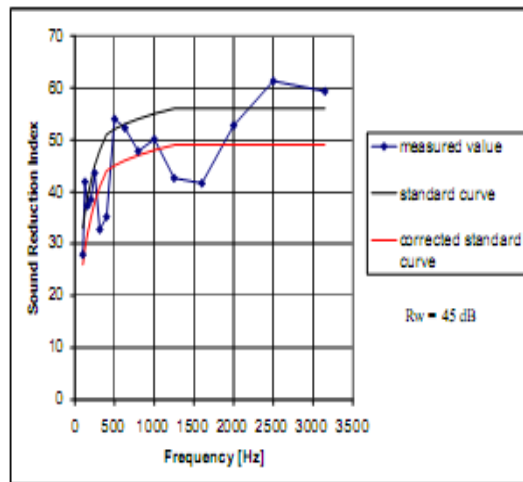

Fig. 2 Assessment of sound insulation

Table 2 Levels of noise in the apartment

Noise Sources	Living Room	Bedroom
Boiler 1	46	47
Boiler 2	41	47
Both the boiler	47	48

As can be seen from Table2. the noise levels at day and night conditions exceed the permissible limits and they are 13 dBA at daytime and 18 dBA at night.

After the measurements of equivalent noise pressure level of each individual noise sources and their third octave analysis, the following conclusions about the characteristics of noise can be defined:

- Noise is of continuous type
- Transmitted both through air and through the structure of the building
- Structural noise is transmitted through fixed connections of existing equipment and walls and floors
- Chimneys transmit noise emitted by furnace in the building .
- All sound sources have a similar intensity of noise, so it is necessary to show noise reduction of each of them .

2 REDUCING THE NOISE PROGRAM

Since success in solving the problem of noise emitted from the equipment in the boiler room depends on many parameters, so can not explicitly find the optimal solution which satisfies legal regulations without being too expensive, cannot be explicitly found. The solution is that the program performs a partial reduction of noise, activity by activity, or in this case in two phases. After each activity is done or achieved control test must be done.

The first phase would be based on the following activities:

- Eliminate all fixed connections of equipment towards the walls, ceiling and floor.
- Mechanical links are necessary to perform over the elastic washer (silencer) or rubber.
- All openings in the ceiling and walls are to close with the flexible insulating material so as to eliminate contact with the pipeline and walls.
- The ceiling set is to set for ceiling insulation against airborne sound.
- Repair or replace all mechanical components that emit high noise levels due to defects or wear and tear, such as: pumps, fans, bearings in terms of reducing noise emissions.
- Regulate fan speed with the required capacity of air.
- Install sound silencers on air intakes at the burner.

The second phase would have continuation with results achieved by the reduction of noise from the first phase and would consist of the following activities:

- Design and installation of flue silencer pipes.
- Vibration insulation of boilers.
- Additional insulation of the supporting walls and barriers.
- Design and construction of low-frequency absorbers (resonant)
- Allocation of existing equipment (transfer to the less critical area)
- Scheduling of different modes of heating.

3. PROGRAM IMPLEMENTATION

3.1. Construction Works

First steps in implementation of this program have been made to repair the building in the construction meaning. As the ceiling is covered with panels are wwcB boards that fell off are cracked in some places, measures have been taken to remove the damaged panels, and replace them with new ones. Also, all openings (eg, the passage of pipes) that were parts of the neighboring buildings are to be sealed with elastic sealing materials such as raw rubber, polyurethane foam, etc..

After setting up sound insulation area the access to the sealing must be implemented in order to reduce the impact of airborne sound influence on ceiling which is also under the nearest dwelling. Suspended ceiling is made in combination of wwcB board and layer of mineral wool in the distances given by Fig.3

3.2 Works on Mechanical Structure

Equipment like boilers, fans, engines, pipes and pumps were fixed on walls and ceiling. This fixing method enables directing the sound and vibration transmission through the construction of the building structure which is far less favorable to tenants in respect of air sound. Therefore, wherever possible it is necessary to physically separate the supporting mechanical structure of these devices from the walls and ceiling. Our supporting structure is fixed to the floor by elastic stands. In cases where it is not

possible, rigid connection is to be replaced by an elastic one. In Figures 4,5,6 the examples of such interventions are given.

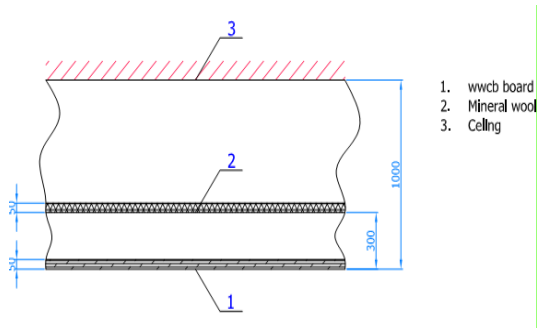

Fig.3 Suspended ceiling



Fig 4. An example of flexible connection

The pump to maintain pressure in the pipes for heating, which works constantly for 24 hours has been replaced by a new one. The reason for replacing the pump is the high level of emitted sound power, which in this case is reduced from 75 dBA to 50dBA. In this way the sound source that disturbs residents in the period when the boilers do not function is eliminated.

In addition, the activities were carried out in mechanical maintenance on equipment in boilers room. Roller bearings were replaced and all position that emit noise were greased. The balancing of the fan rotor was made in aim to reduce vibration and noise.

Circulation pumps and their motors located in room 2. were isolated by the designed enclosures, filled with absorbent material and ventilation directed to the floor. Thus the noise

emission was prevented directly towards the ceiling and apartments in the building (see Fig.4).



Fig.5 Place for enclosure



Fig. 6. changes in the way of fixing

3.3 Fan Speed Alignment

Circulation pumps and their motors are located in room 2. were isolated by the designed enclosures, filled with absorbent material and ventilation directed to the floor. Thus prevented the noise emission directly toward the ceiling and apartments in the building (see Fig.4).

Noise emitted from the fan and flue gas is of great importance to the overall noise level in the apartments. Fan noise is emitted as airborne and structural noise through the walls and ceiling expands into the building. Also we have, the noise and vibration transmitted through the flue pipe and the structure of the building to the pipe and the chimney himself.

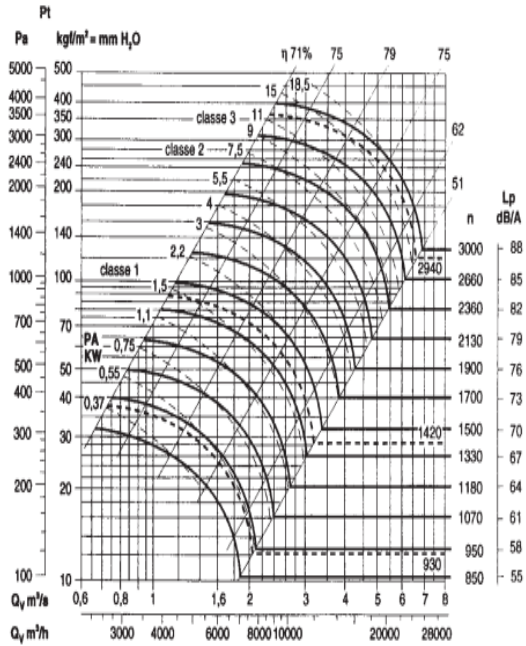

Fig.7 Fan working diagrams

The level of noise issued by fan depends on several components, primarily by the technical characteristics of design and on the other side and the maintenance and adjustment, the system itself.

According to the literature the noise associated with fans is composed of:

1. discrete tones at the fundamental blade passing frequency and integer-ordered harmonics of it: and
2. broad random aerodynamic noise due to vortex shedding from the blades.

When considering the parameters through which one can define the optimal mode of the fan, then these are: type of ventilators, installed capacity, speed, pressure, strain, number of blades, correction and form of adapter on duct. It is clear that the basic requirement to satisfy capacity and pressure. Manufacturers provide the fan working diagrams Fig.6.showing that the reduction of speed is a manner to get the optimal capacity. As is common to the design capacity of the fan system is oversized, it is clear that the reduction in speed can make quieter operation noise of fan. It can be achieved in real terms and up to 15dB.

4. EXPECTATIONS AND CONCLUSION

After the completion of construction and mechanical work, measuring of the reduction of noise levels has been done. It is shown in Fig.7. The measuring was done in 1 / 3 octave band frequency domain and it is evident that there is a significant reduction in noise levels.

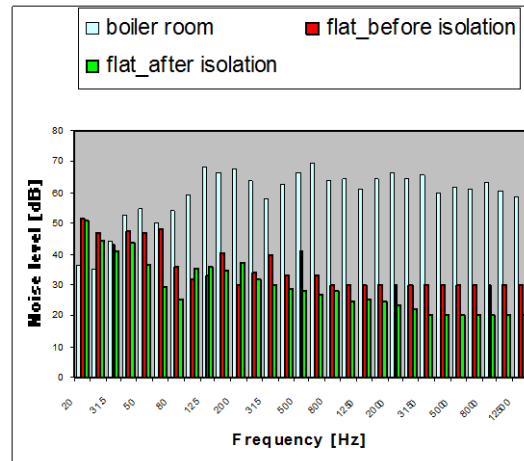

Fig.8 1/3 octave band frequency diagram

Total reduction of noise level for the first two activities is at the level of 6dBA. As the measurement was carried out in the hallway between the apartments it is realistic to expect that effective reduction is 10dBA because there is an additional insulation in the apartment such as flooring and carpets.

Expected results of the first phase of protection against noise are given in Table 3.

It is unlikely that the activities of the second stage noise abatement will be necessary when the first stage is completed.

Table.3 Inspected results of the first phase

Activiti	Noise reduction
Works on Mechanical Structure	2dB
Construction Works	5dB
Fan Speed Alignment	5dB
Burner sound silencer	2dB
Sum	15 dB

Acknowledgement

"Authors wish to acknowledge their gratitude to Ministry of Education and Science of Republic of Serbia for the support to the research through project grant TR37020."

REFERENCES

- [1] Petrović Z., Radičević B., Bijelić M.,- Designing main fan noise protection system in mine »Jarando« Baljevac-, Underground Mining Engineering 15 (2006), 133-138,2006
- [2] Petrović Z., Radičević B., Šoškić Z.,Bjelić M.,-Zaštita od buke industrijskih postrojenja-, XXI Konferencija Buka i vibracije, Tara, str.34., 2008..
- [3] Marshall Long, Arhitectural Acoustics, Elseveir Academic Press, 2006
- [4] Malcolm J. Crocker, Handbook of Noise and Vibration Control, 2007 John Wiley & Sons, Inc.
- [5] Prašćević M.,Cvetkovic D., Buka u životnoj sredini, Fakultet zaštite na radu, Niš,2005