

TRADITIONAL AND
NON-TRADITIONAL
RELIGIOSITY

PUBLISHED BY

Institute of Social Sciences, Belgrade 2019

Yugoslav Society for the Scientific Study of Religion (YSSSR), Niš.

PUBLISHER

Goran Bašić, Ph.D.

Dragan Todorović, Ph.D.

REVIEWERS

Nonka Bogomilova, Ph.D., Bulgarian Academy of Sciences, Sofia

Prof. Pavel Sergeevich Kanevskiy, Faculty of Sociology, Lomonosov Moscow State University

Prof. Zorica Kuburić, Faculty of Philosophy, University of Novi Sad

SERIES

Edited Volumes

SERIES EDITOR

Natalija Mićunović, Ph.D.

Prepared as part of the project "Social Transformations in the European Integration Process:

A Multidisciplinary Approach" supported by the Ministry of Education, Science and

Technological Development of the Republic of Serbia (III 47010)

ISBN 978-86-7093-227-2

ISBN 978-86-86957-21-4

edited volumes

TRADITIONAL AND NON-TRADITIONAL RELIGIOSITY

(A Thematic Collection of Papers of International Significance)

EDITED BY

Mirko Blagojević, Ph.D.

Dragan Todorović, Ph.D.



Institute of Social Sciences and YSSSR | Belgrade and Niš 2019

Contents

- 6**
Mirko Blagojević
Introduction: Religious Change –
Traditional and Non-traditional Religiosity
- 12**
Dragoljub B. Đorđević
New Religious Movements: Typical
Characteristics of a Cult
- 26**
Mijo Nikić, Marina Jurčić
The Challenge of New Religiosity
- 54**
Dragan Todorović
Pentecostalism in Southeastern Serbia
- 76**
Yuri Stoyanov
Contemporary Alavi and Bektashi
Religiosity in Turkey and Balkans-
Traditional Forms and Postmodern
Expressions
- 96**
Vladislav Yeryomin
Concepts of the Unity of Religions in the
Teachings of New Age and the
Traditionalism of R. Guénon
- 114**
Vladimir Bakrač, Predrag Živković, Emil
Hilton Saggau
Some Sociological Aspects of Religiosity
(Religiosity in Contemporary Societies
Between Neo-liberalism and Globalization)
- 136**
Zora Hesová
The Paradoxes of a Return of Religion to
Public Debates and Political Discourses
- 156**
Kjell Magnusson
Religion and Nationalism in Bosnia,
Croatia and Serbia – A Structural Equation
Model
- 184**
Nada Novaković, Marijana Maksimović
Social Development, Traditional Religion
Movements and Migrants in Europe
- 206**
Nataša Jovanović Ajzenhamer
Max Weber on Russia and Orthodoxy: An
Analysis of the Collectivist Ethical Basis of
Eastern Christianity
- 226**
Ольга Смолина
Культурологические проблемы
религиозной жизни украинских земель
В X – XVII вв.
- 248**
Vladimir Mentus
Religiosity and Life Satisfaction in
Economically Developed European
Countries
- 262**
Neven Cvetičanin, Ivana Arsić
New Religiosity, Postmodern Age and
Post-materialistic Values
- 276**
Златко Матич
Пост-традиционное христианство:
православная церковь между
ностальгией и антиципацией

MIRKO BLAGOJEVIĆ
Institute of Social Sciences, Belgrade

Introduction: Religious Change - Traditional and Non-traditional Religiosity

■ Religious life and the connection between people and social groups with religion and church are subject to constant change and different social influences. The history of the Balkans undoubtedly testifies to how out-religious and out-ecclesiastical circumstances (concentrated around the believers' salvation) contribute to the *changes* in the religious and ecclesiastical life of individuals and social groups. These changes are so remarkably strong and obvious that, after a certain period, it is difficult not to highlight social and even political and international factors as inevitable in their explanation, although we are, therefore, exposed to the danger of falling into a kind of sociology. However, between the assertion that the entire religious and ecclesiastical life depends on the constellation of ambient and social circumstances, and the claim that these circumstances affect the spiritual and ecclesiastical sphere, there is an evident difference. Social sciences are the most competent to analyze and explain how and to what extent the social events of the 1970s in Europe and the world have influenced changes in the connection between people and social groups, both with established religions that have existed for centuries, as well as new religious ideas, expressions and practices. These differences also influenced the changed social position of religions and churches in the world. Therefore, the ambient influence on religions and churches is not one-way, since the changed religious situation afterwards influences social roles, culture, politics, morality and general social values.

This approach to religious changes has certain features of methodological reductionism. In this approach, religion does not have, as in the theological, a major but an auxiliary role, because what is primarily sought through religious events is not a religious explanation, but the explanation of the behavior of people and the interaction of social groups as carriers of a certain confessional self-awareness. For instance, the historical circumstances in the

Balkans show clearly that the relations of people and nations cannot be understood without a religious factor. Because this factor is intertwined with the social and public sphere, societies and their mutual relations cannot be understood without their religious and confessional course. Hence, although social factors are important for the explanation of religious phenomena, this phenomenon is not only a social product - there are also gnoseological, anthropological and psychological factors of religion and religiousness.

The deterministic framework of religious changes is made more complex by a number of significant social changes around which there is an agreement as events that paradigmatically confirmed the influence on the change of the position of the religion itself and religious institutions in society, but also the spiritual atmosphere in culture. At work is, on the one hand, gaining the political significance of religious traditions, and on the other, the traditions, while announcing their return, deprivatize the adopted, syncretic beliefs and behaviors, which are essential elements of the process of desecularization of religious life. These events showed that religion did not lose, that is, that it again resurfaced the potentials to inspire great, collective efforts of people for change that relate to the very essence of their political and religious life. In particular, these are the following events: 1. The strengthening of fundamentalism in Islamic countries in the late 1970s, first in the face of Iranian Islamic revolutions, and then in series of Islamic political movements in other countries, Al-Qaeda's so-called "Islamic states"; then 2. The change in the religious situation in a number of Western countries, such as the rise of Christian conservatism in the USA, or the strengthening of radical Christianity in Latin America, as well as the change in the strategy of Catholicism in Europe from the adaptation to the modern world to re-evangelization of that same world, especially with incentives that were supposed to come from Catholicism in the East, mostly from Polish Catholicism as the most effective model. 3. Therefore, as the next important deterministic framework of the religious twist, there is certainly an active or at least a supporting role of religion and church in the destruction of the communist order in Central and Eastern Europe in the late 1980s. On this basis, a religious situation emerged that can be described by terms like radical de-atheization of these societies in the process of

returning or bringing the broad population closer to the suppressed and stigmatized religion and church; 4. On the territory of the former Socialist Federal Republic Yugoslavia and the present Republic of Serbia, in the 1980s, and especially during the wars in 1990s, regardless of the confessions, the growth of public, or more precisely, political abuse of religion, and calming in religious stabilization during the first decade of the 21st century, after wanderings of identity throughout the entire crisis period, for which even today we can not say that it is only a distant memory. 5. The acquisition of the public importance of Orthodoxy in the past year in the Eastern Ukraine and Russia as an identifier, homogenizer and a way to defend the culture in a crisis situation (Blagojević, 2015).

The forecasts of some theoreticians, philosophers and social scientists who advocated the theory of secularization, namely the inevitable disappearance or marginalization of religion and religiosity in the process of modernization of society - were simply not realized. Actually, the exact opposite became visible at the end of the 1980s and in the early 1990s even on the European, the most secularized soil, along with events related to the demolition of the Berlin Wall. Religion and religiosity survived not only as individual-psychological but also as social facts. In other words, religion and religiosity exhibit influence not only on individual consciousness and behavior, but also on collective views and actions. The complex deterministic framework of the reversibility of these phenomena is made up of a number of important changes in social life in the last forty years, both in Europe and in the rest of the world (e.g. the decline of communism, the process of globalization and rise of migration, the decline of postcolonial secular nationalism in the Middle East and North Africa and the rise of the spiritual revolution /Iran/ and various forms of radical Islam). On the one hand, religious traditions in many societies acquire extrareligious, political significance and thereby, on the other hand, deprivatize the accepted, often syncretic, religious ideas and behaviors. Thus, the deprivatization of religious apprehension represents the crucial moment in the desecularization of social life, primarily in some

transitioning, post-socialist societies. Although there is significant (mis)use of religion for non-religious purposes in such circumstances, it is precisely this influence of religious consciousness and the social significance of religions and their hierarchies that points to the moments of desecularization of social life. However, the revitalization of tradition is not the only source of the potential significance of the religious sphere for social life. Pluralization and diffusion of religious expression, especially in developed democracies, are certainly one of the important sources of vitality of religion in the modern world.

In addition to the visible action of different religions in the world (rivalry among them, missionary and the emergence of fundamentalism – (Habermas, 2008) several moments further reinforce their contemporary position (Turner, 2011): the globalization of devotion, the transformation of religion into goods in the market of religious ideas and practices and the occurrence of spirituality, especially in the West. The globalization of religion, therefore, has three forms: global revivalism that concerns traditional forms of religion with orthodox beliefs and practices - either in churches, mosques, temples or monasteries - which include traditional fundamentalism, Pentecostalism and charismatic churches. The second form concerns national and traditional religions that gather those who seek solace, healing, and various kinds of compensation; and, finally, we are witnessing the emergence and spreading of a *new kind of spirituality (of religiousness)*, as heterodox, urban and commercialized form of religiosity, namely, the other side of *traditional, institutionalized* churches (Karpov, 2010). Thus, world religions grow and express their social significance, mostly in relation to identity politics in different parts of the world, while *new religious expressions* and independent churches, originated from the United States, on the other hand, are multiplying and globalizing (Синелина, 2014). By becoming, in part, goods in the market of spiritual products, in some parts of the world the conflict between religion and the secular society is getting milder, as religion enters the framework of the consumerist culture of modern capitalism.

Literature

- Blagojević Mirko. (2015). *Vitalnost religije u (de)sekularizovanom društvu*, Institut društvenih nauka, Beograd.
- Karpov Vjaceslav. (2010). „Desekularization: A Conceptual Framework“, *Journal of Church and State*, Vol 52., No. 2., P. 232-270.
- Синелина Юлия. (2014). „Концепции секуляризации в социологической теории“, в: Памяти Юлии Юрьевны Синелиной, (Научные труды, воспоминания), РАН, Москва.
- Turner B.S. (2011). *Religion in a Post-secular Society*// The New Blackwell Companion to the Sociology of Religion / Turner B. S. (ed.). Wiley-Blackwell.

DRAGOLJUB B. ĐORĐEVIĆ
Faculty of Mechanical Engineering
University of Niš

New Religious Movements: Typical Characteristics of a Cult¹

Abstract

New religious movements – new sects and cults – in comparison with the sects and cults that have been around for several centuries, are considered “new” because they first began to appear in the 1950s, or more significantly at the end of the 1960s, in North America. They act in line with the slogan “Every cult would like to become a sect, and the latter, through denomination, a church” and the practice of “All and everything for the leader, the leader for no one, only for himself”; they possess and require: a charismatic leader, a strict hierarchy of relations, complete separation from the society, complete separation from the family, a small number of members, usually young believers, property and work for the leader, manipulative means and techniques of programming, economic, psychological (and sexual) abuse, and the existence bordering on legality (on the edge of crime).

Keywords: new religious movements, new sects, new cults, North America, typical characteristics.

The religious answers that satisfied our parents do not always satisfy our children. A world-view that can satisfy an agricultural worker in rural Poland will not necessarily satisfy a university professor in Belgrade or a baker in Niš.

Eileen Barker

Introduction: my contribution to the study of new religious movements

■ I hope that it will not be interpreted as my own arrogance if I briefly focus on my actions that have greatly contributed to the

¹ Prepared as a part of the project *Sustainability of the Identity of Serbs and National Minorities in the Border Municipalities of Eastern and Southeastern Serbia* (179013), conducted at the University of Niš – Faculty of Mechanical Engineering, and supported by the Ministry of Science and Technological Development of the Republic of Serbia.

study of cults and sects and new religious movements in the Serbian sociology of religion.

In the now distant 1987, I prepared a special issue on new religious movements, sects and cults for *Marksističke teme* (*Marxist Topics*, 1987, 11[3–4]), a journal of the University of Niš. The issue was received with a warm welcome in the academic community and literally snapped up from Triglav to Gevgelija. As far as domestic authors were concerned, I would like to draw the attention to the articles by Juraj Kolarić, a professor of the Catholic Theological Faculty in Zagreb, then a new-comer from Sarajevo and today a renowned Croatian sociologist of religion Ivan Markešić, and the late Željko Mardešić, alias Jakov Jukić. However, the novelty lay in the translated text by Dmitrij Ugrinovich, a professor from Lomonosov, whose lectures I attended during my post-doctoral stay in Moscow; the article by Roland Robertson from the University of Pittsburgh, who later became famous for his analysis of globalization, and the acclaimed paper by Rodney Stark and William S. Bainbridge (1987, 1979) “*Of churches, sects, and cults: preliminary concepts for a theory of religious movements*”. On the basis of the latter paper, the two authors soon developed a *new theory of religious movements* and an original theory of religion in the spirit of rational choice theory, presented in the celebrated book *A theory of religion*, 1987a.

For ten years I struggled to secure the translation and publication of that book. However, I failed – I was bitten to it by the Slovenians. I still claim if that book had been translated on time, the Serbian sociology of religion would have looked quite differently today!

Ten years after – 1998 – I published a book titled *Prophets of the “new truth”: sects and cults – what should we know about new religious movements?*

As part of the fifth conference of the Yugoslav Society for the Scientific Study of Religion (YSSSR) – 2001 – I published a conference proceedings, titled *Teachings, organization and activities of religious communities and movements*.

And then in 2003 in Belgrade, Žarko Albulj published my book *Sects and cults*, as some sort of a career peak in my dealing with new religious movements. I am very proud of it.

I am also proud of the fact, it being of a much further-reaching importance, that in 1997, I managed to bring Eileen Barker,

from the London School of Economics and Politics, then and now a leading global authority on new religious movements, to Serbia, i.e. Niška Banja, to the fourth international YSSSR conference *Ethnic, religious and confessional relations in the Balkans*. In 2004, I managed to secure the translation and publication of her book *New religious movements: a practical introduction*, which exerted a vast influence on a global scale and which has been published, apart from six editions in Great Britain, in Italian, Dutch, Russian, Polish, Bulgarian, Czech, Hungarian, Spanish and Japanese.

To be fair, new religious movements were also scrutinized in Croatia. In addition to the studies by the unmatched Jakov Jukić, of importance was the 1986 book *New religious movements* by Otto Bischofberger, and a collection of texts under the same title edited by Mijo Nikić in 1997. In 2014 my colleague Josip Blažević also edited a substantial volume titled *New religious movements, sects and cults*.

Typical characteristics of a cult

In our country, even the educated, let alone laypeople, confuse sects (small religious communities) with *cults*, thereby causing the former harm. Cults, as the lowest level of religious organization from the sociological perspective, have recently begun to appear and disappear, light up and die out in turn, with tens of thousands of them existing in North America. Rare are those cults that linger on, gather numerous followers around a “charismatic” leader, establish an organization and begin to spread outside their place of origin. A lot has been written on and talked about how many Americans suddenly experience a “vision”, “become enlightened” and start recruiting members, first within their family and at work, and as soon as they get down on the corner of the block in which they live, the “mercy of God” vanishes and the cult is no longer. For the sake of rarity, it is not strange that in that “land of dreams” one can encounter the Atheist church as well.

This is, indeed, the case of closed small groups with an authoritarian and hierarchical structure, headed by a charismatic leader – to whom members yield completely. The most often recruited are young people, who leave their families, renounce their individu-

ality and private property, succumb to the draconian rules of life, work and missionarying. Roughly speaking, members of a cult live and abide by the rule: *"All and everything for the leader, the leader for no one, only for himself."* Cult leaders are, in fact, very rich people, some of them even magnates of global proportions.

The first thing to remember is that among cults, such as: Ordo Templi Orientis, Aum Shinrikyo, Rosicrucianism, the Children of God, the Baha'i and Computer Sect, the Peoples Temple, the Waco group, Scientologists, Raëlians, Bhagwan Shree Rajneesh²..., there are also those with Satanic teachings and rites, totalitarian and with destructive consequences. Cults possess and require:

A charismatic leader;
A strict hierarchy of relations;
Complete separation from the society;
Complete separation from the family;
A small number of members;
Usually young believers;
Property and work for the leader;
Manipulative means and techniques of programming;
Economic, psychological (and sexual) exploitation of members;

and

The existence bordering on legality (on the edge of crime)
 (Ђорђевић, 2003:34).

This is what partially differentiates a cult from the more dispersed forms of religious organization, even though one should mention here that certain cults, with higher complexity, diverge from the ideal-typical scheme and transform into sects.

Definition and efficacy of new religious movements

In the last couple of decades, this phrase has, indeed, been massively used in discussing sects and cults. It is so prevailing in the

² As a curiosity, when it comes to this cult, little known in our country, there is a popular six-part documentary called "Wild Wild Country", filmed as a story about "a bizarre cult, sex and Rolls-Royces" (Arežina, 2018:49).

western literature that sometimes even the words “sect” and “cult” are absent from the conversation, even though these are nothing more than sects and cults. This threatens to obscure what is happening in those religious bodies.

Therefore, it is advisable to clarify the phrase “new religious movements”: “*New religious movements* (new sects and cults), in comparison with sects up to several centuries old, are truly ‘new’ because they first appeared at the beginning of the 1950s, or more significantly at the end of the 1960s, in North America (Đorđević, 1998:12).” They are partly a result of the democratic processes in the western hemisphere: in every society they support the renewal, development and blooming of religion and religious communities. This is particularly the case, albeit slightly paradoxical, when democratization is performed on the *secular* basis.³ In a civil and democratic, secular and market society there are established rules of conduct and everyone is in obligation to follow them. Success depends only on their ability, adaptability, effort and resourcefulness. This is also the case with religions and religious institutions, thus the following statement does not sound surprising, despite being a well-known fact in sciences on religion and perhaps contrary to our emotional attitude – all religious communities are launched on the market, they are a matter of choice, and they can be chosen, but need not to. One travels the path from the “religion of fate” to the “religion of choice”. (The data shows that some American converts or changes their religious group three times during their life.)

They are surely “effective”: some of them genuinely, because they spread, grow and become more complex, while others are notorious for tragic incidents and constantly occupy newspaper columns and television programs. Certainly, most examples come from the United States of America. In that pluralistic pit, the young are increasing turning to new religious forms of gathering, seeking the answers to contemporary socio-psychological questions. These young souls, sensitive to any kind of problem, are being dragged into certain new religious movement by employing the manipulation technique – particularly the so-called brainwashing, and further

³ The same standpoint was taken by Peter Berger in his early, secularist phase.

programmed and transformed into obedient “soldiers” of cults and new sects. Most them, sociologists claim, become dysfunctional for the more immediate and wider community, and face many difficulties when subjected to “deprogramming” and reintegration.

There are also numerous incidents and tragic events. We are regularly reminded of Charles Manson, the killer of Sharon Tate – a rising film star and wife of director Roman Polanski – and his group from the “crazy sixties”; the three and a half decades old mass suicide of the members of Jim Jones’s “Peoples Temple” cult in French Guiana⁴; the death of the followers of David Koresh, a cult leader from the small place in Texas called Waco, some twenty years ago; the latest passing of a “computer” sect in California; the famous poisoning in the Tokyo subway⁵; and the collective immolation of the “Ten Commandments of God” sect in Uganda. I am conveying two accounts here:

The tragedy of the “Branch Davidians” cult – Bearing in mind that the group was armed to the teeth, equipped with explosives and completely isolated on a ranch near Waco, it attracted the attention of the FBI and the Bureau of Alcohol, Tobacco and Firearms (ATF). After a marathon siege of the community, which lasted for 51 days, as well as an unsuccessful attempt to enter its main building, the final showdown resulted in the death of the total of 86 members of the cult, including David Koresh himself and more than twenty children (Vukomanović, 1998:88–96).

Kampala – “More than two hundred people, members of a Christian sect in Uganda, committed a mass suicide by immolation on Friday”, the police said yesterday. “The members of the ‘Ten Commandments of God’ sect was closed in the church, and there are a lot of dead people in there, including children”, said the police public relations officer Eric Naigambi. The tragedy happened in the town of Kanunga, some 320 kilometers southwest from Kampala,

⁴ The tragedy was masterfully analyzed by the greatest contemporary Italian sociologist Franco Ferrarotti in his essay “Religion and chaos: the case of the ‘Peoples Temple’” (Ђорђевић, 2001:194-198).

⁵ In 1995, the followers of the “Aum Shinrikyo” cult carried out a deadly sarin attack on a subway station in Tokyo and killed 13 people, which is considered the deadliest terrorist attack in the history of Japan. It was not until this year that the seven leaders of the cult were executed, including the founder Shoko Asahara (Аноним, 2018:23).

following the predictions of the imminent apocalypse by a group of excommunicated priests and nuns. The members locked themselves in the church, with the windows boarded up, and later set it on fire.

The completely charred bodies were found in the middle of the church, and the police did not find any traces of struggle. Before the collective suicide, the second in the world in terms of the number of victims, the members of the sect gave away all of their property to the poor (AFP, 20 March 2000).

Anti-cult and procult movement

The destructiveness of such religious groups, along with the demands from the wider citizenry and especially parents, led to the formation of a strong *anti-cult movement* in America, followed by other western countries – and more recently in Russia as well.⁶ Within this movement, voluntary activity and expert council is provided by numerous representatives of appropriate professions: psychiatrists and psychologists, sociologists and social workers, jurists and lawyers, university professors and scientists, politicians, priests, etc. These people do not merely use the theoretical means, i.e. a determined public campaign, to unmask the inhumane and criminal behavior of certain cults and new sects, but also work practically on deprogramming the people who have left them and who wish to be reintegrated into the 'normal' social and family life. It is precisely these new religious movements that can be responsibly marked as being dangerous both for the individuals and the community.

Western countries neither help nor hinder the activities of anti-cult movements. They protect the freedom of conscience, the freedom of religion and the freedom of religious gathering and ensure equality for all religious bodies: large and small, developed and undeveloped, institutionalized and newly-established, millennia-old and newborn, sects and cults, denominations and churches.

⁶ In the last several years the most prominent figure has been "father Alexander Novopashin, hegumen of the Alexander Nevsky Cathedral in Novosibirsk, consultant and associate of the Ministry of Interior of the Russian Federation, associate of the Prosecutor's Office for the fight against organized crime, expert in issues concerning totalitarian sects and destructive cults..." (Јовановић, 2017:38–42).

No one is excluded from monitoring and control, but the state reacts only in those cases where laws are broken, and criminal activity is present. Even then court proceedings can last for years.

Truth be told, let us note here the death sentence of Jeffrey Lundgren, better known as the “Kirtland killer” and the leader of the “Lundgren group” from Missouri, a cult related to the Reorganized Church of Latter Day Saints, for having viciously murdered several of his followers: “On April 17, 1989, the Averys were invited to the farm, fed a last supper, and then enticed one by one into the barn where first the parents and then the children were shot by Lundgren using his ‘favorite’ weapon. The order of execution was designed to minimize resistance. The bodies were placed in a shallow, prepared grave. Damon Lundgren (Jeffrey’s son – D.B.Đ. comment) was appointed look-out, but performed relatively ineptly, becoming physically ill. Back at the farmhouse, the women pretended not to know what was taking place and facilitated the ‘delivery’ of victims. Gregory Winship ran a chainsaw to muffle the sounds of the shots” (Mekfirson, 1998:99).

Furthermore, an adequate sentence was also passed on the parents of an adult woman, member of the religious community the Way Ministry, for having taken her from the community by force, not voluntarily, and subjecting her to deprogramming:

“One form of alleged manipulation has been that of preying on susceptible subjects. For example, in *Peterson v. Sorlien* (1980), a Minnesota Supreme Court case, a 21-year-old woman brought charges against her parents after they tried to have her deprogrammed from a group called The Way Ministry” (Jang & Grifit, 1998:82–83).

In addition, a doctor-deprogrammer was also sentenced for knowingly subjecting a young person to treatment without their consent:

“An example is the case of *People v. Patrick* (1982) from the California Court of Appeal, 4th district. The well-known deprogrammer, Theodore Patrick, appealed against a kidnapping conviction for his actions in helping a family’s attempts to abduct their daughter. He had made a defense of necessity, asserting that his unlawful conduct should be excused because it was directed against an emergency that threatened greater harm than did his behavior...

The trial court, seeing this argument as having the effect of putting the victim's beliefs on trial, refused to go along. Pointing out that no danger of imminent physical harm to the alleged victim had been claimed by the defendant, the court also had a problem defining psychological harm to a consenting victim who spent 6 years with the religious group. The Appeals Court agreed, and Patrick's conviction stood" (Jang & Grifit, 1998:80).

Similarly to this, there are cases where a damaged adult person does not want to submit to psychotherapy, 'getting out of the clutches', or taking a witness stand during a trial of a prosecuted group leader. This is exactly what has been going on with India Oxenberg, our fellow countrywoman, daughter of the Hollywood actress Catherine Oxenberg and granddaughter of princess Jelisaveta Karađorđević:

India Oxenberg (26)... continues to show loyalty to the NX-IVM sect even after an investigation of its leaders has been launched under serious charges of human trafficking and sexual exploitation of girls... Jelisaveta has spoken to India several times and visited her at the restaurant where she works because she wants to help her. The restaurant owner also wants to hire a psychotherapist to help India, but that will be a difficult process due to her being brainwashed" (Чарнић, 2018:10).

Along with the anti-cult movement, by definition, there immediately rises a *procult movement*, which often trumps its counterpart in terms of visibility on the public scene, strength and influence. Its existence in democratic systems is fully legitimate, thus it also includes, as in the former case, a number of experts and powerful individuals of all sorts. This is supposedly not an anecdote: the first thing that madam Madeleine Albright, former US Secretary of State, despised in our country for performing this function during the NATO bombing, said at the airport upon meeting Mr. Klaus Kinkel, German foreign minister, went along the lines of – "What are you in Germany doing with the Church of Scientology?" Namely, the Germans were about to ban this very influential cult from operating when they saw through their scheme by which their members had been cunningly infiltrating company managements and state administration, creating a personal union and parallel power structures. The Austrians also had to assemble their parliament on a

short notice and officially declare, until then unacknowledged, Scientological cult as a church before the visit of Bill Clinton, former US president, as much stigmatized in our country as madam Al-bright. This cult, which I have already classified as a developed religious movement, but with suspicious business transactions – informers claim that it operates just like any other multinational company – has powerful protectors among politicians, business-people and, perhaps crucially, Hollywood stars (for example, the cult receives much care and attention, incidentally or following the ‘from cult to cult’ motto, from John Travolta and Tom Cruise – cult actors): “Irrespective of the ‘real’ motives, the CoS operates as a commercial enterprise. It provides goods and services that are in demand, it caters for the needs of particular sections of the population, a good number of its activities are geared toward profit, and many of the CoS’s troubles with the law are typical of those found in the commercial world” (Pasas & Kastiljo, 1998:108).

Conclusion: from a cult to a developed religious movement

While sects are developed religious organizations and movements, cults do not have to necessarily grow into a developed religious movement. This depends on the level of organizational complexity, as I explained earlier. Stark and Bainbridge (1979:117-131) write about cults existing at the level of an *audience*, a *client cult* and a *cult movement*. Whereas a cult as an audience possesses almost no organization and membership is reduced to consumer activities, in the client cult type “the relationship between those promulgating cult doctrine and those partaking of it most closely resembles the relationship between therapist and patient, or between consultant and client”, with a cult movement being a true religion “which can be distinguished from other religious movements only in terms of the distinctions between cults and sects developed above”; or more precisely, “audience cults provide *mythology*, client cults add serious *magic*, cult movements are *true religions*.”

It somehow appears that in our country, for example, the Silva Method would be a cult of audience, i.e. a popular consumer my-

thology, Transcendental Meditation a client cult, in other words - modern magic, and the Church of Scientology a cult movement, i.e. a true religion.

Furthermore, cults, as non-schismatic phenomena, can be divided into *cultural novelties* and *imported constructs*. In Serbia, it seems that, excluding the traditional churches and old Protestant communities, i.e. sects in the sociological sense, the tens of new religious groups are nothing more than imported constructs. We do not have, as far as I am aware, a domestic cult, an original religious group as a cultural novelty.

Some of these new religious movements have grown roots here as well, albeit not to the extent to which we are being overwhelmed by means of mass communication. The latter, especially newspapers and television, are rather prone to incidents and exclusive headlines, instead of vehemently supporting the formation of an anti-cult movement (providing room for a procult movement as well).⁷

Unfortunately, we do not possess any valid data on small religious communities – old sects, new sects and cults – that operate legally or covertly in Serbia. The data that is available, and I emphasize this, is practically unusable. The major shortcoming of the studies on small religious organizations stems from the non-existence of experiential background. Instead of being grounded in authors' empirical insights and first-hand observations of the life of these religious bodies, they are far too 'theoretical', mainly based on other people's frequently suspicious reports, inauthentic and brimming with incorrect information. This is the same malady from which other publications of our writers on religion also suffer.

⁷ I have already recommended that "the society can act in three permitted ways: 1) by passing legislation on religious communities and a separate by-law, which would be used to regulate the area of quasi-religious expression, i.e. the existence of occult, Satanic, totalitarian, destructive and semi-secret groups and associations, those that possess no religious flavor in the civilized sense of the word 'religion', and finally separate "the wheat from the chaff", religious organizations from quasi-religious and proto-religious ones; 2) by providing a favorable atmosphere for the development of a cultivated anticult movement, without prohibiting the operation of its procult counterpart; and 3) by establishing humane institutions for the reintegration of those returning from and escaping the above stigmatized (quasi-)religious movements, by respecting the freedom of conscience and personal decisions of all adult citizens in the field of faith" (Đorđević, 1999:257-258).

I proclaim that we lack *the research 'from within'* the concrete religious groups and that is why we do not know enough about old sects, for example – the Church of the Nazarene⁸, the Christian Baptist Church or the Seventh-day Adventist Church⁹, let alone about new sects and cults, such as the various Pentecostal currents¹⁰, Ordo Templi Orientis, the Hare Krishna movement, Scientologists or the White Rose. That is why we receive basic information on them from police officers and tabloid journalists, people unlearned and unskilled for such a responsible job.¹¹

Literature

- Аноним. (2018). „Погубљено седам вођа култа Аум Шимрикио, међу њима и главни лидер Шоко Асахара“, *Народне новине*, 7–8. July, pp. 23.
- Arežina, Luka. (2018). “Wild Wild Country”, *Nedeljnik*, 12. April, p. 49.
- Barker, Eileen. (1989). *New Religious Movements*. London: Home Office.
- Barker, Ajlin. (2004). *Novi religiozni pokreti*. Niš: Zograf.
- Bischofberger, O. (1986). *Novi religiozni pokreti*. Đakovo: Biskupski ordinarijat.
- Blažević, Josip. (ed.) (2014). *Novi religiozni pokreti, sekte i kultovi*. Zagreb: Veritas.
- Vukomanović, Milan. (1998). Dejvid Koreš i kult „Davidovog izdanka“ – učenje, odbrana i poslednji dani, u Đorđević, Dragoljub B. *Proroci „nove istine“: Sekte i kultovi – Šta treba da znamo o novim religioznim pokretima?*, pp 88–96. Niš: JUNIR, Društvo za zaštitu i unapređenje mentalnog zdravlja dece i omladine.
- Ђорђевић, Драгољуб. Б. (1987). „Зашто ‘православци’ прелазе у адвентисте?“ *Марксистичке теме*, 11(3–4):141–149.
- Ђорђевић, Драгољуб В. (1998). *Proroci „nove istine“: Sekte i kultovi – Šta treba da znamo o novim religioznim pokretima?* Niš: JUNIR, Društvo za zaštitu i unapređenje mentalnog zdravlja dece i omladine.

⁸ See: *The Church of the Nazarene* (Ђорђевић, 2003).

⁹ Consult the original attempt: “Why do the ‘Orthodox’ convert to Adventists?” (Ђорђевић, 1987:141–149).

¹⁰ Praise should be given to Dragan Todorović’s study (2011) *The protestantization of the Roma in southeastern Serbia*.

¹¹ The most recent example is the article by Igor Milosavljević (2018:9) “Legal advice: protect yourself from sects!”

- Đorđević, Dragoljub B. (1999). "Anti-Cult Movement: A Possible Expression of Religious Intolerance", *Facta Universitatis Series: Philosophy and Sociology* 6(2):257–270.
- Ђорђевић, Драгољуб Б. (2001). *Социологија forever*. Ниш: Пунта.
- Ђорђевић, Драгољуб Б. (2003). *Секте и култови*. Београд: Жарко Албуљ.
- Ђорђевић, Сања. (2003). *Хришћанска назаренска заједница*. Ниш: ЈУНИР, Пунта.
- Јовановић, Наташа. (2017). „Отац Александар Новопашин.“ *Печат*, 6. October, pp. 38–42.
- Jang, Džon L., Grifit, Ezra I. H. (1998). Kultovi i vrbovanje članstva, u Đorđević, Dragoljub B. *Proroci „nove istine“ Sekte i kultovi – Šta treba da znamo o novim religioznim pokretima?*, pp. 79–88. Niš: JUNIR, Društvo za zaštitu i unapređenje mentalnog zdravlja dece i omladine.
- Ljosa, Mario Vargas. (2018). „Mala Španjolka i princ Gurdijev.“ *Nedeljnik*, 19. July, pp. 15–16.
- Mekfirson, Sandra B. (1998). Ubistvo u kultu i smrtna kazna, u Đorđević, Dragoljub B. *Proroci „nove istine“: Sekte i kultovi – Šta treba da znamo o novim religioznim pokretima?*, pp. 96–102. Niš: JUNIR, Društvo za zaštitu i unapređenje mentalnog zdravlja dece i omladine.
- Милосављевић, Игор. (2018). „Правни савети: заштитите се од секти!“ *Народне новине*, 18. June, p. 8.
- Nikić, Mijo. (ed.) (1997). *Novi religiozni pokreti*. Zagreb: Filozofski fakultet Družbe Isusove.
- Pasas, Nikos, Kastiljo, Manuel Eskamila. (1998). Sajentologija i njeno „čisto“ poslovanje, u Đorđević, Dragoljub B. *Proroci „nove istine“: Sekte i kultovi – Šta treba da znamo o novim religioznim pokretima?*, pp. 103–112. Niš: JUNIR, Društvo za zaštitu i unapređenje mentalnog zdravlja dece i omladine.
- Stark, Rodney & William Sims Bainbridge. (1979). „Of Churches, Sects, and Cults: Preliminary Concepts for a Theory of Religious Movements.“ *JSSR*, 18(1):117–131.
- Старк, Родни, Бејнбриџ, Вилијам С. (1987). „О црквима, сектама и култовима: уводни појмови за једну теорију верских покрета.“ *Марксистичке теме* 11(3-4):182–199.
- Stark, Rodney & William Sims Bainbridge. 1987a. *A Theory of Religion*. New York: Peter Lang.
- Тодоровић, Драган. (2011). *Протестантизација Рома југоисточне Србије*. Београд: Филозофски факултет (doctoral dissertation).
- Чарнић, Доротеа. (2018). „Индија Оксенберг не жели да изађе из канци секте.“ *Политика*, 29. April, p. 10

MIJO NIKIĆ

Faculty of Philosophy and Religious Sciences
University of Zagreb, Croatia

MARINA JURČIĆ

Foundation „Biskup Josip Lang”, Zagreb, Croatia

The Challenge of New Religiosity

Abstract

The new religious movements are community of believers who have separated themselves from their already existing large religious communities and continue their own way by creating new beliefs for themselves. Unlike the movement, these followers are better organized and have a firmer internal hierarchical structure. The slogans often radically interrupt all ties with the larger religious community they used to belong. New religious movements and religious sects represent a great challenge for society and the church, and we cannot remain indifferent towards them. This phenomenon is a double challenge for us: on the one hand, it causes us to seriously reconsider ourselves, our faith which has perhaps lost the power of yeast, which for many is no longer the salt of the earth and the light of the world. If that is not the case, then it is no wonder that new religious movements are successful because they offer exactly what true Christians should be. Another challenge is the need to critically examine new religious movements and religious sects and discover obvious or, as is often the case, hidden pitfalls and dangers in the form of new addictions that lie in them. New religiosity mostly gives preference to emotions over reason and relativises what is absolute, and it absolutizes what is relative. The followers largely nurture the fundamental, uncritical interpretation of the Bible. The Church and the state must defend the youth and protect them from destructive sects and new religious movements that manipulate them. Sects that serve the methods that endanger the mental integrity of a person or encourage young people to some criminal offenses must be prevented and sanctioned.

Keywords: new religiosity, sects, religious dependence, church, society

Introduction

■ It is difficult to define the notion of religion since its dynamic reality escapes statistical data and strictly scientific classification. Đuro Šušnjić rightly says that “every definition suffers from an inevitable disadvantage: the static form of definition is the betrayal of the dynamic nature of the process that this definition can not fully express nor describe. If we have a definition - there is no more process, and if we have a process, there is no definitive definition” (Šušnjić, 1988: 36). Therefore, this author considers that “science should leave its definitions permanently open for a new experience” (Šušnjić, 1988:36). Bearing that in mind, alongside the standpoint of the aforementioned author, we are considering that religion is going to be defined in the end as the sheer openness of a men’s spirit towards the Transcendence. This is, indeed, a general statement, but it expresses the true essence of religiosity. It consists of the deepest need of a man to meet the Absolute One and find the answers to the most troubled questions: the meaning of life and death, and the possibility of a life after death. Philosophy issues these questions, but the religion provides the answers. These answers are only to be accepted by faith. Faith is the acceptance of the God’s authority. A religious man becomes a believer only when he is obedient to the God and when he accepts God’s revelation and reconciles his life with the will of God.

Religion, yet, may be defined as “the system of beliefs, ethical values, and the acts by which man expresses his relationship with the sacred” (Rebić, 2002:798). This relationship can be subjective and objective. In subjective relationships, an individual expresses his respect and adoration toward God’s personally, and such relationship is called religiosity. When this relationship is expressed in the religious community through words (prayer, belief, etc.) and various rituals using sacred objects, we may talk about religion or a religious institution. In 20th and 21st century, new religions, which promote new religiosity, have emerged, spreading through various religious or pseudo-religious sects and new religious movements. They are most often deployed from some of the existing religions and have a strong charismatic leader. Religious followers have a firm structure and often undefined obedience to their leader. New

religious movements are less structured and therefore, they involve a big number of believers because they allow greater freedom of belief and behaviour. At the Consistory of Cardinals, held in 1991 Rome, Cardinal Arinze talked about four types of new religious movements: 1) the Christian movements based on the Scriptures; 2) New religious movements that originated in other religions, such as Hinduism, Buddhism or other traditional religions; 3) Movements in which the elements of paganism are more present than elements of true religiosity; 4) The gnostic sects offering Enlightenment in their naturalistic searches (1).

Man had long sought for answers to the existential questions which had found in those great traditional religions. However, recently, a new religiosity emerges tremendously and rapidly through the above-mentioned new religious and pseudo-religious sects and new religious movements, becoming a major challenge for society and traditional religions. In this new religiosity, there is a lot of syncretism and uncritical acceptance of various beliefs that are sometimes contradictory. In this paper we will strive to clarify this statement and will show how religious beliefs and new religious movements emerge, how they gain new members, what methods of advertising they use and what impact they have on the society as a whole. Finally, we will bring the strategy of the Roman Catholic Church in a response to the challenge of the new religiosity. Note that the phenomenon of this new religiosity within religious sects and new religious movements will be approached from the scientific point of view and the focus of Catholic theology.

The Preoccupation of the Roman Catholic Church

The Roman Catholic church has expressed the preoccupation about the sects and new religious movements in the document VATICAN REPORT: SECTS OR NEW RELIGIOUS MOVEMENTS: A PASTORAL CHALLENGE, issued on May 3, 1986 (2). "As a first step in this study project, a questionnaire was sent out in February 1984, to Episcopal Conferences and similar bodies by the Secretariat for Promoting Christian Unity in the name of the aforemen-

tioned departments of the Holy See, with the aim of gathering reliable information and indications for pastoral action, and exploring further lines of research. To date (October 1985), many replies have been received by Episcopal Conferences on all continents, as well as from regional Episcopal bodies.”

1. Reasons for the Emergence and Dissemination of Sects and New Religious Movements

According to this interdisciplinary document, these are the reasons of the appearance of the sects and the new religious movements:

1.1. Quest for Belonging (Sense of Community)

The fabric of many communities has been destroyed; traditional lifestyles have been disrupted; homes are broken up; people feel uprooted and lonely. Thus, they need to belong.

The sects appear to offer: human warmth, care and support in small and close-knit communities; sharing of purpose and fellowship; attention for the individual; protection and security, especially in crisis situations; resocialization of marginalized individuals (for instance, the divorced or immigrants).

1.2. Search for Answers

In complex and confused situations people naturally search for answers and solutions. The sects appear to offer: simple and ready-made answers to complicated questions and situations.

1.3. Search for Wholeness (Holism)

Many people feel that they are out of touch with themselves, with others, with their culture and environment. They experience brokenness. They have been hurt by parents or teachers, by the church or the society. They feel left out. The sects appear to offer: a gratifying religious experience; room for feelings and emotions, for spontaneity (e.g., in religious celebrations); bodily and

spiritual healing; help with drugs or drinking problems; relevance to the life situation.

1.4 Search for Cultural Identity

This aspect is very closely linked with the previous one. In many third world countries the society finds itself greatly dissociated from the traditional cultural, social, and religious values; and traditional believers share this feeling. The sect appears to offer: plenty of room for traditional cultural and religious heritage, creativity, spontaneity, participation, a style of prayer and preaching closer to the cultural traits and aspirations of people.

1.5. Need to be Recognized, to be Special

People feel a need to rise out of anonymity, to build an identity, to feel that they are in some way special and not just one more face in the crowd. The sects appear to offer: concern for the individual; equal opportunities for ministry and leadership, for participation, for witnessing, for expression; awakening to one's own potential, the chance to be part of an elite group.

1.6. Search for Transcendence

This expresses a deeply spiritual need, a God-inspired motivation to seek something beyond the obvious, the immediate, the familiar, the controllable, and the material to find an answer to the ultimate questions of life and to believe in something which can change one's life in a significant way. The sects appear to offer: The Bible and Bible education, a sense of salvation, gifts of the Spirit, meditation, spiritual achievement.

1.7. Need of Spiritual Guidance

There may be a lack of parental support in the seeker's family or lack of leadership, patience, and personal commitment on the part of church leaders or educators. The sects appear to offer: guidance and orientation through strong and charismatic leader-

ship. The master, leader or guru of the sect plays an important role in binding of the disciples.

1.8 Need of Vision

The world of today is an interdependent world of hostility and conflict, violence and fear of destruction. People feel worried about the future, often despairing, helpless, hopeless, and powerless. The sects appear to offer: a “new vision” of oneself, of humanity, of history, of the cosmos. They promise the beginning of a new age, a new era.

1.9 Need of Participation and Involvement

This aspect is closely linked with the previous one. Many seekers not only feel the need of a vision in the present world society and toward the future, but they also want to participate in decision making, in planning, in realizing. The sects appear to offer: a concrete mission for a better world, a call for total dedication and participation on most levels.

By way of summary, one can say that the sects seem to live by what they believe, with powerful (often magnetic) conviction, devotion, and commitment; going out of their way to meet people where they are, warmly, personally, and directly, pulling the individual out of anonymity, promoting participation, spontaneity, responsibility, commitment, etc., and practicing an intensive follow-up through multiple contacts, home visits, and continuing support and guidance. They help to reinterpret one’s experience, to reassess one’s values and to approach ultimate issues in an all-embracing system. They usually make convincing use of the word: preaching, literature, and mass media (for Christian groups, strong emphasis on the Bible). Therefore, they present themselves as the only answer, the “good news” in a chaotic world.

However, although all these counts mostly for the success of the sects, other reasons also exist, such as the recruitment and training techniques and indoctrination procedures used by certain sects.

Understanding the New Age Movement's Ideas and Techniques

According to Joseph Hopkins, the religious movements and religious encounters created in the New Age ambiance are presented as spiritual, social and political movements that have the power to transform the individual as well as the global society. Various techniques of mystical enlightenment, that include mind, body, and spirit are offered for this transformation. Most successful examples of such divine transformation techniques are: yoga, prayer, creative visualization, hypnosis, and an undefiant service to the guru (3). Since every human by its nature is inclined to always seek for an easy solution to the many difficult problems, it is no wonder that it is readily caught in the wide spread net of these offerings, rather selecting meditation and visualization than a true conversion of the mind and heart to become a new man.

Depersonalized Relations and Apocalyptic Mentality

In addition to authentic religious motivation, the reasons for new religiosity may be economic and political interests, and in some cases: just ordinary curiosity. Depersonalized relationships in the family, as well as in the society, often motivate young people to seek protection and acceptance in the ambiance of religious enslavement and new age movements. Stefaan van Calster, in his psychological and sociological reflection on the phenomenon of religious enslavements and movements, cites an example of a woman from Munich who was in the process of experiencing a sense of protection, which she lacked in her own family: "... a man of warm heart is accepted and immediately embedded in the life of the community ... I felt very much at home very quickly." On the basis of her thinking, the author concludes that it should not be surprising that there are those who leave their parishes and enter sects and new religious movements where they feel protected and experience human warmth (Vaan Calster, 1992:42-43). The apocalyptic mentality of the 20th and 21st century is only one of the reasons for the emergence and the spread out of these religious sects and new religious movements. The rise of the new millennium has the power to awaken the mythical content of consciousness in people

that is prone to apocalyptic vision of the world. Many modern prophecies announce the partial ruin of the world. It's not a pure speculation, it's a real danger. Namely, accumulated atomic weapons have the power to destroy this planet. "The awareness that an erroneous move by an individual is sufficient for the full end of everything that exists is not just a matter of literary film speculation, but also the cognition of millions of people." (Grakalić, 1994:31).

Religious Relativism

Postmodern society is reluctant to ignore a rational explanation of reality, emphasizing the emotional assessment, and holding it more to the affective, rather than reason. In such an atmosphere, a lush religious relativism that equate all religious attitudes thus give legitimacy to any religious experience and religious attitude. According to the principle of religious relativism, no religion alone has a monopoly over the truth, nor it alone has the means of salvation of the man himself or the society in general. According to Jean Verette, a well-known new religionist, religious relativism has led to awakening of paganism, magic, and other forms of religious expression different from the values offered by the Bible and Christianity (4).

Religious Sects and Movements as a Phenomenon of Desecularization of Society

Religious sects and new religious movements appear just as equally in the poor and endangered, as much as in the highly civilized rich societies. It is therefore a universal phenomenon that could be interpreted as an expression of "religious awakening" in post-modern society. Namely, the secularization of society has led to the breaking up of traditional social structures that have given the individual its security and protection. In this empty space, now, loose religious beliefs, which create the emotional state of the group, protect their members from the outside world, presenting themselves as an ideal refuge in the face of catastrophes that threaten the entire mankind.

Magic and Occult in the Emergence and Spread of Some Sects

There is not always a clear line of delimitation between religion and magic in religious denominations and new religious movements. Magic seeks, irrespective of the deity, to reach out to the hidden knowledge and the authority over the human kind, by the embracement of which one could influence the higher powers, secret forces or divinity itself. Many sects use magic and occult elements in various ways. In addition, bizarre occurrences, unexplained murders, and collective suicides in the ambience of new religious movements and sects profoundly demonstrate the influence of satanic forces. Cardinal Francis Arinze was convinced of this: "We must not exclude devotional activity among the various interpretations of the emergence and spread of enslavement or of new religious movements, although it is hidden from the persons involved in these convictions. The enemy sows the weeds while people are sleeping." (5)

Unconscious Motivation as a Driving Force for Entering Religious Beliefs

Unconscious motivation is an integral part of every human psyche and is present in many human activities. It is especially strong in the youth, while choosing the profession as a young person and in the selection of various religions and new religious movements they may enter. Some researches have shown that many young people are driven by the unconscious motivation to take revenge on their parents who did not like them or did not care enough for them, so they join some bizarre sects to revitalize their parents (6).

Religious Sects and New Religious Movements as the Universal Phenomenon

Religious, or pseudo-religious sects, as well as new religious movements, are a universal phenomenon. Today they are present on all continents of the world. It can be said that from around one hundred thousand people in the city centre, about one thousand

young people are directly affected by the new religious groups. It is estimated that almost three-quarters of all those who have only once accessed a trace of a religious movement of some sort, later seek another or completely abandon a new type of religiosity. According to the Catholic Church Institution's survey (7), the greatest enslavement at present is happening today in South America where well-organized and financially strong new religious movements from North America, who are often very hostile to the Catholic Church, which is still the most numerous, come and recruit their followers. In some rich circles, the Catholic doctrine of faith, especially the Christian social doctrine of the Catholic Church, which is devoted to the poor, strives to be eliminated as just as the influence of the Church in people and as much as possible through the use of powerful means of public communication thrown in the hands of the new age movements leaderships. When it comes to the exact number of religious beliefs and their followers, it is difficult to give accurate data as they change on a daily basis. It is estimated that in the US alone there are over 20,000 movements. There are also over one hundred of them in Croatia. It is estimated that the new religiosity nowadays encompasses nearly 500 million people worldwide.

The Fundamental Aspects of Sects and New Religious Movements

New religious movements and religious sects as a phenomenon of the modern society, mostly give preference to affectivity over reason, meaning that most of them are dominated by various enthusiasms, some weird mysteriousness and subjective visions and twisting, often at the border of the hysterical behaviour.

The sects largely nurture the so-called fundamental, uncritical interpretation of the Bible, drawing words out of the context and interpreting it subjectively and spontaneously at their own will, often altering them in the opposite direction – side lines into the ones of the main importance and vice versa. There is no recognition of validity of any other road to Salvation but their own, since, by the interpretation of the sect, only their doctrine leads to the fi-

nal goal unconditionally and unmistakably, and those who join them are 'elected ones' (8). Devotion based experience is highly valued in their circles, as well as personal dedication.

In the high number of sects, the private declarations, various visions and prophecies, ecstatic phenomena and obsession with clairaudient plays a decisive role. Most sects neglect the objective and deny every scientific interpretation of the religious experience, but rather call for more attentiveness and the will power, ignoring or excluding every reasoning and pure common sense. They are utterly convinced that they are the only ones "elected" to be saved. Although there are many peace-loving and tolerant sects, there are also those that represent a great danger to the freedom of people, especially the young and our society in general. By their structure, the sects are authoritarian; used to functioning with a well-established brain drain and mental control, collective coercion, exacerbate feelings of guilt and an overwhelming fear among their followers. Renata Sprung, the disciple of Jehovah's Witnesses, testifies in her book "Bez zatvora" ("Without a prison"), that after this nice and friendly reception, another side to the medal is quickly shown. She literally says: "The spying in pursuit is very widespread among Jehovah's. That's what we learned well on our own skin. Any deviation from the Line of the Guard Watchers was passed up in the written message to the Assembly. It is tragic that some of the Jehovah's are not aware of their own business, but denounce it in good faith, holding that as if they are making a God pleasant act of mercy, so that their brothers and sisters may be rescued from their spiritual death" (Sprung, 1996:30). In Society, we have not felt anything from the divine freedom enjoyed by the children of God. Jehovah's witnesses are mostly living in constant fear before the Armageddon, literally trembling before it, while some other members are overwhelmed with vanity, for they are so terribly sure to be saved...

Movements that have their living charismatic leader are completely subordinate to him, and he is very authoritative and often requires total obedience. The program of these movements is different and varies from non-Christian to anti-Christian attitudes. The number of followers ranges from several hundred to several million. There are movements with predominantly male and those

with predominantly female members. Some integrate into society, others isolate. Some are aggressive in their propaganda, others are passive. The most vulnerable and the most popular group involved in a religious affiliation are young people who are out of work, inactive in the life of their parish or religious community, coming from an unusual family environment, troubled in a certain way or belonging to ethnic minorities and living in places largely away from the influence of the Church.

Promotion and the Process of Winning New Members

Victims of religious sects and new religious movements are most commonly slightly ill and insecure persons that usually suffer from certain conscious or unconscious fear of self-reliance. Such people are looking for any kind of falsified reality that could offer them some, although temporary, emotional refuge that provides the sensation of security they so much long for. The process of recruiting members can be seen in the following four stages:

The First Degree – a potential follower is attracted most often by a member of the opposite sex who invites the candidate to a meeting that occurs mostly at the end of the week. The old member then speaks of how he had serious problems before in his life, but since his sect is at his hand, everything is fine all over again, and he is now happy and successful in his business. When potential sectarians find their sanctuary in a religious ensemble or in a guru, then the transformation phase occurs.

The Second Degree – the other sectarian members, now fellows of the new candidate, treat him with great care and love, so that he is bombarded by their affections ('love bombing'). They keep praising the new member who has chosen their society, sharing the necessary medicines and food with him.

The Third Degree – most often, a new member through various seminars or other forms of initiation, will be further 'informed' and formed. Meanwhile, the ambience is tightly controlled by the sectarians and they try to separate their new member from his parents and friends, to be able to quickly adopt a new way of thinking

and behaviour as soon as possible. In this environment of a great isolation there is a kind of 'brainwashing' going on in order for the recruited to abandon not only his old beliefs, but also old friends, even parents and closest relatives, should they oppose his sect's choice. New members are kept in constant tension and must always deal with something new, so that they would never be left alone to themselves and their own lucid thinking. For this purpose, they are incentives and persuasions of the leader, constant formation, the destruction of inner resistance, the provocation of fears that the candidate cannot overcome without the help of the leader or the guru to whom he must be obedient. Founder and leader of the unification Church Sun Myung Moon explicitly told his followers: "I am your brain".

The Fourth Degree – the new member is fully embedded in the sect and he is now beginning to be a missionary himself. He starts out and begins to gain new members and occupy certain positions in the sectorial hierarchy. The Guardian of the Child of God, David Berg, has asked members of his family to deal with prostitution in order to gain new members and raise money for the needs of the followers. American academician Larry D. Shinn, investigating the reasons for his hostile attitude to the tragedy of Hare Krishna, concludes that it is no wonder people think that this 'brainwashing' is happening, since young people who become Krishna fans must make a radical and traumatic way of making a jump from Western culture into a completely new, full-fledged, strictly hierarchical ensemble, which greatly frightens the parents of young followers of this religious movement (Cf. Shinn, Larry D.).

New Religion - a Challenge for the Church and the Society

New religiosity is a great challenge for all Christian churches proclaiming Jesus Christ as the Son of God and the Saviour of the whole World. Namely, new religiosity is an alternative to the Christian message of salvation by Jesus Christ, who is, for a Christian believer, the only Saviour of the world. New religious movements of non-Christian origin do not believe that Jesus is the Son of God, but

one of the avatars, or the embodiment of the deity, but not the only and not the greatest. These movements explicitly say that man does not need salvation by Christ, but needs only enlightenment, need only a guru, a leader, a teacher, who will bring him to the enlightenment in which salvation is in the far end. Even some followers of Christian orientation do not proclaim Christ as the only Saviour any more.

1. The Challenge for the Church:

The Interpretation of Jesus Christ in New Religion

According to Christians' belief, more precisely, according to the doctrine and belief of the great traditional Churches: Roman Catholic, Orthodox, and Protestant, Jesus Christ is the God's Only Begotten Son, the true God, who became the true man, who died and rose from the dead for the salvation of the world. Commitment to Jesus brings eternal salvation, and God offers eternal happiness to those who accept His Son. Jesus claimed for himself that He was 'resurrection and life', and on that occasion proclaimed that all those who accepted him would share his destiny: "He, who believes in me, even if he dies, will live." (Jn 11:25).

It should be said that the true truth about Jesus began to distort itself already in the first centuries of the emergence and development of Christianity. The so-called Apocryphal Gospel as well as some heretic texts about Jesus were "always copied again" (Barišić, 2017, 22). The new religiosity that spreads today through various enslavements and new religious movements, when speaking of Jesus Christ, takes many elements from the Apocryphal Gospels, especially from Gnostic Heredity. According to Ivan Karlič, "many (Christian) Gnostics distort or accept the core message of New Testament announcement, i.e. the reality of the incarnation of the Son of God, Jesus Christ, diminish or completely deny his human right as well as his saving torment, death and resurrection" (Karlič, 2017:33). The author in question rightly claims that the character of Jesus Christ is present in new religiosity "in a truly specific and weird way, sometimes as a figure of fantasy, sometimes in a glorious manner, depending on which circle and which ideology (called spirituality!) a certain follow-up stands." (9)

Many religious encounters in the New Age ambience, when they speak of Jesus Christ, seem to be inspired by the learning of Hinduism and Buddhism. According to Hinduism, Jesus Christ is one of the incarnations of the deity. He is therefore an avatar (10). It is a mythological perception of the deity that is embodied on the earth to teach people to go through in order to avoid various catastrophes. "When Hinduism connects Jesus and the concept of avatars, it usually does with the avatars of the Godhead: Krishna and Rama, while Buddha are sometimes added to them as the most prominent Vishnu avatar" (Mršić Felbar, 2017:51).

The Buddhism of Jesus is most perceived as the exalted Master who is in harmony with the Buddha when he teaches these themes: love of enemies; returning to the good of human beings; advocacy of generosity; self-criticism instead of condemning others; a life devoted to acquiring virtue through humility. Islam as well as some sects and movements derived from the ambience of Islamic faith are considered by Jesus as the forerunner of God's Messenger. "To Him is the Almighty Allah revealed the Gospel (Good News). He was a Muslim, which means obedient to Allah, and Allah's choice" (Mešić, 2017:65).

The Qur'an confirms that Jesus (Isa) was born without a father, but he does not admit it to the Son of God, or to God, as the Christians believe. "The Qur'an in more than one place sharply denies such a claim as untruthful and blasphemous" (Mešić, 2017:69).

Joseph Smith, the founder of Mormon, or the Church of Jesus Christ of Latter-day Saints, has seen the Holy Trinity as three gods. Biblical anthropomorphism is often misunderstood by the Mormons. Thus, their sacred record *Doctrine and Covenants* (130:22) says: "The Father (God) has a body of flesh and bones, equally tangible as the human body."

Jehovah's Witnesses maintain that the doctrine of God as the Trinity (Trinitarian learning) is pure human fabrication and the left over from the old pagan perception of the divine in the Christian understanding of God (Gelo, 2018:85). According to their doctrine, Jesus Christ is not the Son of God, and His Immortality has only been acquired by His resurrection.

According to the doctrine of the Universal Life, Jesus Christ is the Son of God the Father and the first female non-human being.

The mentioned sect is a pure New Age product that takes on all religions from all religions and attributes them to God the Father and Jesus Christ.

Adventists of the Seventh Day or believers of the Christian Adventist Church honour Saturday as the biblical day of rest and Christ's second coming. According to one disciple of this church, they are very anti-Catholic: "Adventists have an anti-Catholic attitude very pronounced" (Žiga, 2017: 148). The unification church founded by Sun Myung Moon (1954), according to the Catholic Church's conviction, is not a Christian church because there is no proper doctrine of the Holy Trinity (11).

There could be many more examples that confirm that new religiosity is present in various sects and new religious movements are a great danger to the doctrine of the Catholic Church in terms of preserving the purity of its faith.

2. Religious Struggling and New Religious Movements - a Challenge for Society

Except for the Church, new religious movements and religious or pseudo-religious encounters are a great challenge, and sometimes a real danger to society as such, regardless of whether they are believers or unbelievers. Namely, there are known cases of murders or suicides that occurred in the ambience of destructive sects and new religious movements. Let's just mention some:

On November 18th, 1978, a serious crime occurred in the Sect of the Temple of Nations. Namely, over 900 members of this bizarre American sect committed suicide in Guyana or were violently killed, at the command of their founder and leader Jim Jones, (12).

On the night of October 4th and 5th, 1994, 16 burned corpses were found in France and Switzerland, amongst them three of the children who belonged to the religious movement of the Sun Temple.

In Japan in 1995 there was a case of the mass poisoning in the Tihi subway, ordered by the members of the Aum Shinrikyo family. The aftermath of 13 people killed and more than 5,500 injured, while Shoko Asahara, the leader of the cult responsible for this sarin gas attack, got sentenced and executed by hanging, alongside six more of his followers.

In 1997, at the invitation of their professor, 39 young people killed themselves in Heaven's Gate sect. Although these young people were very capable in computing and made websites for various companies, they were, yet, completely naive and utterly convinced that some spacecrafts would take them to the higher spheres of consciousness if they are ready to leave this world by committing a collective suicide, which is exactly what they all did. Their motive for this act of collective suicide was a singular wrong conviction that the kingdom of heaven, as an evolutionary level above every human being, is a physical place located in the Universe that can be easily reached by their own forces, i.e. by abandoning their physical body, and so they left their bodies behind (Introvigne, 1997).

That is why it is not surprising that the newspaper *L'Express* on December, 28 1995, writing on the Sect of the Sun Temple chose the headline of the article as: "Secte: le récit de l'enfer" – "Sect – a tail from the Inferno". The words belong to Jean Vuarnet, Edith Bonlieu's husband, after she took her own life in a mass suicide with other cult members from the Solar Temple Sect. Of course, this title cannot be strictly used as to refer to all of the followings. Namely, they are not all so aggressive and destructive, but it is true that some of them are very pernicious, not only for the Church, but also for the society in general, that continues to nurture them, not only from the world afar, but also in our midst.

New religious movements and religious sects are a real challenge, towards which the society and the Church cannot remain indifferent. This phenomenon is a double challenge: on the one hand, it causes Christians to seriously re-examine themselves, especially their faith that may have lost the strength of the yeast, and is no longer the salt of the earth and the light of the world for many more of them and around them, as it should be, according to the words of Jesus (13). If Christians are no longer true Christians, then is no wonder that these new religious movements are successful because they seem to offer exactly what true Christians should be and reflect in the world. Another challenge is the need to sincerely, but also critically, examine new religious movements and religious sects, discovering the obvious as well as, more often, hidden traps and dangers in the form of new addictions occurring in certain religious sects.

Declaration on Religious Freedom of the Second Vatican Council solemnly proclaims that every human being, in a private or public, individual or common form, has the right to a religious freedom. It is necessary to respect that freedom, but also the right of every person to know the truth. Here is the question for the state: What kind of relationship should it nurture with religious movements and ensembles? We believe that the state should take on this phenomenon with the same attitude as all other civic associations. This means that the state law should respect the freedom of conscience and religious affiliation of every citizen. However, the state is obliged to react when threatened by the freedom of its citizens, when families affected are unable to cope with the problems created by their own children that became members of some traitor's sects, seeking money or other valuable things. Then, the state must defend young people and protect them from methods used as raids that endanger mental integrity of a person or encourage young people to commit some criminal acts punishable by the law of the same State.

The Church's Attitude Towards New Religion and Religious Consequences

The Extraordinary Synod of the Bishops held in 1985 noted that some people are seeking answers to their questions in the following because they do not find them in the Church in the way they would like to and therefore representing a challenge and a call for the restoration of the whole Church. The so called 'following' are signs of time and therefore "must be constantly analyzed". The document entitled Evangelizing 'secularized' Europe, issued by the Council of the Episcopal Conferences of Europe (Rome, 7-11 October 1985), speaks of the spiritual void the people of our times experience, especially the young who are in danger of becoming victims of radical and fundamentalist ideologies of some new religious movements. In this context, the document speaks of the masters of wisdom who, through religious sects and movements, offer their own therapy for the problems of our time. Also, the extraordinary consistory of Cardinals, held in April 1991 in the Vatican, discussed

about the present religious convictions. One of the topics of this cardinal set, according to the wish of St. John Paul II himself, was “The Annunciation of Jesus Christ Before the Challenge of Success”. In the concluding statement of the Cardinal, it is said that the appearance of the enslavement is worrisome to the Catholic Church since believers are not always able to withstand the attractiveness that religious communities of this kind have and the fact that they fascinate people all over the world, on all continents.

While maintaining a dialectical attitude towards religious convictions, Pope John Paul II has made it clear that one of the important reasons for the propagation of the new age movements is the great economic and financial aid received by those who spread the confusion and preach deception while at the same time attracting simple and unlearned people to a religious experience.

1. Religious Sects and New Religious Movements are the Signs of Time

In fulfilling its mission, the Church must know how to read and recognize the signs of time and to do so in the light of the Gospel. In his speech to the bishops of Ghana in 1993, Pope John Paul II speaks of the signs of time and explicitly states that “those who have accepted the work of preaching must read the signs of time, both positive and negative.” In the same speech, the Pope cites the negative signs of our time in the form of the emergence of the ensembles and the new religious movements that are referred to the alleged apparitions, prophecies, and miraculous healing. The attractiveness of these movements, the Pope stated, sometimes comes from their apparent ability to respond to the spiritual need of people and the hunger in their hearts for something deeper, like curing, comforting and meeting the Transcendent.

2. Pastoral Guidelines of the Church

2.1. Develop a Living Faith through Small Communities

The Church invites to re-examine the traditional parish community system and find models of lesser communities in which believers will be better acquainted and more experienced, as true brothers and sisters and close neighbours.

2.2. To Enliven the Liturgical Participation in the Eucharist

The Eucharist is the strongest force that should connect and guard believers in communion with Christ. In other words, intensive Eucharistic life should help believers to preserve their faith and not become victims of various religious movements that endanger their faith in Christ - the only Saviour. The Phenomena Sect (3.3) notes that special attention has to be devoted to the dimension of experience, or to the personal disclosure of Christ, happening mostly in prayer, the Eucharist, and engaging one's life in the service of the Gospel. There is a personal encounter with the living Christ in the Eucharist, which becomes the power of the believer to endure and overcome all the temptations he is exposed to in the modern world.

2.3. Strengthen the Participation of Lay People in the Duty of Evangelization

Pope John Paul II calls on bishops to ensure that believers get authentic catechesis and form smaller communities that will exercise the function of evangelizing the world. Some bishops have set up information centres to study work and spread religious beliefs and provide timely information and pastoral support on individual cases occurring in the ambience of new religious movements and enslavement.

2.4. Develop a Systematic Biblical Upbringing in Faith

The basic religious document on religious followings made up as the response of the Episcopal Conferences in the World on the phenomenon of new religiosity warns all those in charge of the Church to emphasize the teaching of the biblical, theological and ecumenical plan. Encouraged by alternative methods of treatment, meditative techniques of prayer, and the teaching of various religious movements, people do not stand alone and therefore we need to help them in critical evaluation of the new religiosity that spreads today through various sects and new religious movements. The return of paganism, superstition, and religious syncretism en-

dangers the faith of many Catholics. That is why catechetical education in faith is needed not only amongst the young, but also for elderly people. The Church is aware that the unfamiliarity with the essential truths of one's own faith is a great enemy of the faith itself. Therefore, a demand is laid on its officials that their faithful receive a solid biblical education. A very solid dogmatic-biblical upbringing in your faith can be achieved by serious study and adoption of religious truths from the latest Catechism of the Catholic Church (Cf. Nikić, 2010:291-325).

Conclusion

New religiosity, as we have seen, is indeed a great challenge for all traditional Christian churches, as well as the entire society. Over the last two centuries religious relics and new religious and pseudo religious movements are the symptom of the modern society state. Many people who opt for a new religiosity in religious denominations and new religious movements are most likely to sincerely seek God, even in the wrong places. Cardinal Arinze claims that new religious movements are a reflection of the spiritual need of an individual whom the Church or other religious institutions have not perceived or do not know how to respond to, regarding their needs and rising demands (Arinze, 1994, 128). However, the sects are not the right solution and they cannot respond to the basic need of a human heart seeking truth and authentic happiness. Sects capture freedom and create addictions in their subjects. The image of the Most Holy Trinity, especially the image of God the Father and Jesus Christ offered by the new religiosity, presented at the ensembles and by the religious movements, is largely distorted, consciously or unconsciously. It could be said that the sects are not quite so guilty about it, but the society that produced the need for such forms of conjuring worship and religious movements. Speaking in a metaphorical way, we might say that we have no need for replacing the sick fish in the stale water but replacing the water itself with a bucket of fresh pour. Society needs to change its mentality, its ideology, its power centres. The Mankind needs to change the spirit of this world. In other words - we must once again

evangelize Europe and the earth, becoming the salt and shining the light.

The necessity of this action was clearly outspoken by the Roman Catholic Church in its document "Jesus Christ - the bearer of living water". The Church has devoted this document to believers and to all people of good will with the intention of giving them Christian reflection or a more precise Catholic view of the ideology and spirituality of the new age that, through various religious sects and new religious movements, touches all of the palms of the society. New Age is seductive because it promises a lot. That is why serious thinkers put it into utopian movements. On the one hand, it is a symptom of society and culture that is in a deep crisis and on the other hand New Age is, according to the Church's understanding, the wrong answer to the deepest desire of the human heart for happiness and the universal peace. This document correctly addresses Christ and New Age, clearly outlining the fundamental truth, which the Church believes in, remaining strong in the conviction that Christ is the bearer of the living water, which every human heart longs for. Anyone who drinks from the wells of the New Age and various sects will go thirsty again and be tempted, but whoever is drinking from the water that Jesus Christ will give him, will certainly never need to search for another well. But whoever drinks the water I give him will "But whoever drinks of the water that I will give him will never be thirsty again. The water that I will give him will become in him a spring of water welling up to eternal life" (John 4:14), says Jesus in a conversation with Samaria, who long wandered for happiness in the wrong places until he met Jesus who offered her water flowing into eternal life.

Notes

1. Cf. Kard. Arinze , F. „Izazov sljedbi i novih religijskih pokreta: pastoralni pristup“ (Challenging Sects and New Religious Movements: A Pastoral Approach. General Report). Rome: April 5. 1991, generalno izvješće, Rim, 5. travnja 1991.
2. Challenging Sects and New Religious Movements: A Pastoral Approach. General Report. Rome: April 5. 1991.

3. In response to the concern expressed by Episcopal Conferences throughout the world, a study on the presence and activity of "sects," "new religious movements," [and] "cults" has been undertaken by the Vatican Secretariat for Promoting Christian Unity, the Secretariat for Non-Christians, the Secretariat for Non-Believers and the Pontifical Council for Culture. These departments, along with the Secretariat of State, have shared this concern for quite some time and then made this document together (<https://www.ewtn.com/library/NEWAGE/VATREPERT.TXT>. September 10, 2018).
4. Cf. Hopkins Joseph M. Experts on Nontraditional Religions Try to Pin Down the New Age Movement. In: *Christianity Today*. May 17. 1985; Washington D.C: 68-69.
5. According to this author, four elements are associated with the emergence of new religiosity: 1) restoration of elements of archaic religiosity such as magic, superstition, witchcraft; 2) revival of some myths and elevation of idols associated with various forms of religiosity; 3) enacting Christianity to a purely cultural level, emphasizing only the subsidiary elements of Christian religiosity; 4) the restoration of Gnosticism by which man is saved by his knowledge. Cf. Néopaganisme. In: Poupard Paul (ed.). *Dictionnaire des religions*. Paris; PUF; 1993:1420-1423.
6. Arinze kard. Francix. The Challenge of the Sects or New Religious Movements: A Pastoral Approach", u: *Sects and Religions - Quarterly Review of Religious Culture*. GRIS. 13, January-March 1 1994:130.
7. Otto Bischoferberger brings the conviction of a journalist from Stern who studied the followers of Hare Krishna in Germany, who concluded that it is not India's wisdom that attracts young people, but the desire to revenge their parents: "What they mumble is an adventure, a challenge. May them be a religious crap, which considers all the reasonableness, enlightenment and advancement of the world of their parents as stupid." (Bischofberger Otto. *New Religious Movements*. Đakovo; UPT; 1986:16).
8. Compare document Phenomenon Sects or New Religious Movements, a Pastoral Challenge.
9. "The sect usually closes into itself, pulls itself to" the wicked world, "and establishes only the most profound relationships with society. In general, the outside world is demonizing, and it sacralizes its own life in a community of like-minded people. The sect in the wilderness of the world strives to be an oasis. It is understood that in such a mechanism of black-and-white projection of the world, only good is seen in itself, and in the other, only evil and danger" (Tadić Katarina, Stipe Tadic. *Jesus Christ in the Interpretation of the Universal*

Movement of the Religious Movement. In: Blažević Josip, Šimunović Josip (ed.). Interpretation of Jesus Christ outside Christianity. Zagreb; Veritas; 2017:100.

10. Karlić Ivan. Op. cit. p. 38. According to this author, there are three basic ways of understanding Jesus Christ in new religiosity: a) sects of Jewish-Christian provenance; b) sects and movements created in New Age ideology and c) esoteric sects. Representatives of Jewish Christian sects advocate a return to the so-called "Original Jesus and Christianity". These "sects" of Jesus are considered by the Messiah, the Savior and the Son of God, but they completely obliterate his humanity. It seems as if some of the Christian chivalry of gnostic orientation from the early centuries of the Church has been stirred up (Ivan Karlić, op. cit. p. 38). The New Age Movement is considered by Jesus as the Enlightened Teacher, the Great Guru, Yogis, but not the Single-born Son of God. In other words, he denies Jesus' divine identity and his single role in the history of the salvation of mankind. Looking at Jesus in a cosmic perspective, the New Age provides a picture of Jesus who would be a manifestation of the divine, one of the many incarnations of God that helps man to better acquaint himself with himself and to activate in himself his own psychic energy and thus spread his consciousness and reach the divine world within himself. "Obviously, the historical person of Jesus of Nazareth, Christ, the incarnate Son of God, remains marginalized there. In addition, in the sects of such a direction is felt a (new) gnostic trace" (I. Karlić, 38). Finally, sects from the esoteric environment teach that Jesus was a wizard who was as young as he went to Egypt where he learned the techniques of hypnosis and suggestions, which later helped him in his miraculous work in Palestine. Such an approach reduces Jesus to the character of a wanderer, a wizard, a shaman, or a psychotherapeutic healer. (More on this subject can be found in Gramaglia P. A. Gesù Cristo in esoterism and masonry. Giaveno (TO): 1992). The classic example of esoteric biographies of Jesus Christ was given by Notovitch Nicola. The Buddhist Gospel of the Way of Jesus. Paris: 1894.
11. "The word avatar literally means 'descent' and signifies the appearance of a deity in human form." (Jan Peter Schouten, Jesus as Guru.) The image of Christ among Hindus and Christians, Amsterdam-New York: 2008:274.
12. In its Declaration on the Moon's Church, the unification of the bishop of Japan, this explains his attitude to Moon's teaching: The basic beliefs of the Church of Unity are published in the book of Divine Principles. The teaching proposed by this book denies the fundamental dogma of the Catholic Church; the revelation that reaches its peak in Christ, the deity of Christ and his re-

- demption on the Cross. A) According to our faith, the revelation has its fullness in Christ. According to the Unification Church, Christ's revelation is incomplete, so Sun Myung Moon, sent by God, is the true Messiah who completes the revelation, and he and the final Savior of mankind ... "(Declaration of the Bishops' Conference of Japan in the Holy Spirit Community for the Unity of World Christianity of 22 June 1985. According to the Veritas, Blažević Josip. The Church of the United Rev. Moon. In: Veritas 9 2001: 19.
13. <https://www.historytoday.com/richard-cavendish/jonestown-mass-suicide> (30. 8. 2018)
14. "You are the salt of the earth; but if salt has lost its taste, how shall its saltiness be restored? ... You are the light of the world. A city set on a hill cannot be hid" "(Mt 5: 13-14).

Literature

- Arinze kard. Francix. (1994). The Challenge of the Sects or New Religious Movements: A Pastoral Approach", u: Sects and Religions - Quarterly Review of Religious Culture. GRIS. 13, January-March 1.
- Barišić, Anto. (2017). Isus Krist u apokrifnoj literaturi (Jesus Christ in the Apocryphal Literature), in: Josip Blažević – Josip Šimunović (ed.), Interpretacija Isusa Krista izvan kršćanstva (Interpretation of Jesus Christ outside Christianity). Zagreb.
- Bischofberger, Otto. (1986). Novi religiozni pokreti (New Religious Movements), Đakovo; UPT.
- Deklaracija Biskupske konferencije Japana u pogledu Zajednice Svetoga Duha za ujedinjenje svjetskog kršćanstva od 22. lipnja 1985. godine. Navedeno prema pisanju u listu Veritas. Blažević, Josip, „Crkva Ujedinjenja velečasnog Moon“, u: Veritas 9(2001) 19.*
- /The Declaration of the Japanese Bishops' Conference on the Holy Spirit Community for the Unity of World Christianity of 22 June 1985. According to the review Veritas, Blažević, Josip, "The Unification Church of the Rev. Moon", in Veritas 9 (2001) 19/.
- Gelo, Milan. (2017). Isus Krist u učenju Jehovinih svjedoka (Jesus Christ in the Teaching of Jehovah's Witnesses). In: Blažević Josip, Šimunović Josip (ed.). Interpretacija Isusa Krista izvan kršćanstva (Interpretation of Jesus Christ outside Christianity). Zagreb; Veritas.

- Grakalić, Marijan. (1994). Duhovnosti novog doba, historiozofska monografija (Spirituality of the New Age. Historical Monograph). Zagreb; Arkadia.
- Gramaglia, P.A. (1992). Gesù Cristo nell'esoterismo e nella masoneria, Giaveno (TO).
- Hopkins Joseph, M. (1985). Experts on Nontraditional Religions Try to Pin Down the New Age Movement. In: Christianity Today. May 17.; Washington D.C: 68-69.
- Introvigne, Massimo. (1997) Heaven's Gate. Collana Religioni e Movimenti. Leumann/Torino; Editrice elle Di Ci.
- Karlič, Ivan. (2017). Kristološke hereze tijekom povijesti Crkve (The Christian Hereses in the History of the Church). In: Blažević Josip, Šimunović Josip (ed.). Interpretacija Isusa Krista izvan kršćanstva (Interpretation of Jesus Christ outside Christianity). Zagreb; Veritas.
- Mešić, Mirza. (2017). Jesus, Isa, Mesih, Sin Merjemin/Isus, Mesija, Sin Marijin – Poslanik Islama (The Messiah, the Son of Mary / Jesus, the Messiah, the Son of Mary - the Prophet of Islam). In: Blažević Josip, Šimunović Josip (ed.). Interpretacija Isusa Krista izvan kršćanstva (Interpretation of Jesus Christ outside Christianity). Zagreb; Veritas.
- Mršić Felbar, Iva. (2019). Isus Krist u velikim svjetskim religijama (Jesus Christ in Great World Religions). In: Blažević Josip, Šimunović Josip (ed.). Interpretacija Isusa Krista izvan kršćanstva (Interpretation of Jesus Christ outside Christianity). Zagreb; Veritas.
- Nikić, Mijo. (2010). Slika Boga u vjerskim sljedbama i novim religijskim pokretima (Image of God in religious sects and new religious movements), Filofofsko-teološki institut DI, Zagreb.
- Notovitch, Nicola. (1894). The Buddhist Gospel of the Way of Jesus. Paris.
- Poupard, Paul. (1993). (ed.). Dictionnaire des religions. Paris; PUF.
- Rebić, Adalbert. (2002). (ed.). *Opći religijski leksikon* (General Religious Lexicon). Leksikografski zavod Miroslav Krlež. Zagreb.
- Schouten Jan, Peter. (2008). Jesus as Guru. The Image of Christ among Hindus and Christians, Amsterdam-New York.
- Shinn Larry, D. (1987). The Dark Lord: Cult Images and the Hare Krishnas in America. Philadelphia; Westminster Press.
- Sprung, Renata. (1996). Zatvor bez zidova - bili smo Jehovini svjedoci (Prison without walls - we were Jehovah's Witnesses). Knjižnica „Marije“, Split.
- Šušnjić Đuro. (1988). *Znati i vjerovati* (Know and believe). Stvarnost - Kršćanska sadašnjost. Zagreb.
- Tadić, Katarina.; Stipe, Tadic. (2017). Isus Krist u interpretaciji religijskog pokreta Universalni život (Jesus Christ in the Interpretation of the Religious Movement Universal Movement). in: Josip Blažević – Josip Šimunović (ed.), Interpretaci-

ja Isusa Krista izvan kršćanstva (Interpretation of Jesus Christ outside Christianity). Zagreb; Veritas.

Van Calster, Stefaan. (1992). „Ljudi bez doma“ (People Without Home). in: *Svesci* 2-4(1992) 42-43.

Žiga, Robert. (2017). Svjedočanstvo bivšeg starješine Adventista Sedmog dana (Testimony of Ex-Seventh-day Adventist Elder). In: Blažević Josip, Šimunović Josip (ed.). *Interpretacija Isusa Krista izvan kršćanstva (Interpretation of Jesus Christ outside Christianity)*. Zagreb; Veritas.

DRAGAN TODORVIĆ
University of Niš,
Faculty of Philosophy

Pentecostalism in Southeastern Serbia¹

Abstract

The paper gives a survey of the history of the Serbian evangelist movement, significantly influenced by Roma participation: the greatest religious communities are concentrated in Roma *mahalas* in Niš, Leskovac, Vranje and other towns in Southeastern Serbia. Leskovac, which boasts an exclusively Roma Pentecostal Church (better known as “The Church under the Tent”, with a few hundred baptized believers), is considered as the center of Evangelical Christianity. In conclusion, we are discussing the potentials of evangelism of Southern Serbia for encouraging ethnic reaffirmation by cultural rebirth and by advocating for political dialogue and praxis.

Keywords: Pentecostalism, Serbia, Southeastern Serbia, Roma People.

55

edited volumes

The Basic Characteristics and Development of Pentecostalism²

■ Though popularized in the early twentieth century in the USA (Charles Fox Parham and William J. Seymour), the Pentecostal Movement³ is founded on the perfectionist and charismatic

¹ Prepared as part of the project *Sustainability of the Identity of Serbs and National Minorities in the Border Municipalities of East and Southeast Serbia (179013)*, carried out at the University of Niš – Faculty of Mechanical Engineering, and supported by the Ministry of Education, Science and Technological Development of the Republic of Serbia.

² More extensively on the development of the Pentecostal religious communities on the Balkans and in Serbia in Тодоровић 2011b, 2012a.

³ Pentecost (Greek Πεντηκοστή (Pentēkostē) meaning “fiftieth,” the Feast of Weeks or the Feast of 50 days); the Christian festival celebrating the descent of the Holy Spirit on the disciples of Jesus after his Ascension, held on the seventh Sunday after Easter. It refers to the final Jewish festival celebrated on the fiftieth day after Passover – celebration of the Mosaic covenant at Mount Sinai.

movements of the nineteenth century, most of all the Methodist Holiness movement and the Catholic Apostolic Movement after Edward Irving (Anderson 2005). This led to many teachers and students turning to the study of the Holy Scripture in order to find the evidence for baptism by the Holy Spirit.

As a world movement, Pentecostalism passed through three periods in its historical development: 1. *Classical Pentecostalism* (at the time of its origin, it attracted socially, economically and psychologically deprived persons while the contents of their gatherings included prayers, intense physical manifestations, healings, glossolalia); 2. *Neo-Pentecostalism* or *Charismatic Renewal* (in the fifties of the twentieth century spread among middle and high classes; independent groups were formed; stressed is life in the Spirit and practice of special spiritual gifts; schooling of pastors started in their own schools); and 3. *The third wave* (in the eighties of the twentieth century); insistence on the experience of the Power of the Holy Spirit in healing the sick, exorcising demons, receiving prophecies and participating in other manifestations of the Pentecostal type) (Marinović Bobinac 1999).

In time three different traditions of the Pentecostal denominations became crystallized: 1. denomination of Holiness-Pentecostal tradition (continuing the original Azusa Street views); 2. denominations of the Baptist-Pentecostal tradition (denomination of the *Assemblies of God*); and 3. denominations of the Oneness Pentecostal tradition (denomination formed out of the doctrinal divisions within the *Assemblies of God* between 1914 and 1916 that refuse to believe in the Holy Trinity). Nine more important characteristics of the Pentecostal movement are: 1. focus on Jesus Christ; 2. stress on the celebration of God the Father and Son Jesus Christ; 3. love for the Word of God; 4. belief that God speaks to his people even today; 5. preaching of the Gospels; 6. awareness of evil; 7. stress on the use of spiritual gifts (gifts of speaking in tongues, of prophesy and healing); 8. eschatological waiting for the second coming of Christ; 9. works within the Power of the Holy Spirit (celebration, preaching of the Gospels, service of healing, exorcism and conquering evil and service with spiritual gifts) (Jambrek 2007, 286).

The Pentecostals, like other Protestants, have two main rituals that most of them would refer to as *ordinances*, the ordinance of baptism and the ordinance of Holy Communion or the Lord's Supper as well as three subsidiary ones: ritual of dedicating children (parents together with the communion pray for the health of their children), wedding and funeral service. In the Pentecostal movement of the greatest importance is glossolalia or speaking in tongues when people appear to speak in languages unknown to them as well as "baptism in the Holy Spirit", as a sign that the Holy Spirit "poured out upon" the believer. After the first water baptism, the phenomenon of "speaking in tongues", expressed in incomprehensible utterances, shouts and sighs, is considered as a clear sign of baptism in the Holy Spirit.

Soon the message of the Gospels preached in the Power of the Holy Spirit spread across North America to Europe, namely, Scandinavian countries, Italy, as well as Middle and South America, Africa and Asia. The movement also grew in Russia, Bulgaria and Romania, mostly thanks to returnees from America.⁴ Referring to the latest world research, Jambrek (2007, 183) states that in mid-2000, out of 1,999,564,000 Christians in the world, 523,767,000 participated in the Pentecostal Charismatic movement.⁵ Using the data from the World Christian Encyclopedia (2001), Anderson (2005) presents the data that the overall number of the Pentecostals of all kinds is 535 million, out of which 65 million are Pentecostals, 175 million Charismatics and 295 million followers of the "third wave" or so-called Neo-Charismatics. The overall number of followers of these three groups (in millions) is estimated as 79,6 in North America, 37,5 in Europe, 141,4 in South America, 126 in Africa, 134,8 in Asia and 4,2 in Oceania. Since 1947 there has been *The World Federa-*

⁴ Robert Mapes Anderson (2005, 7029) states that "Pentecostalism was brought to Bulgaria, Romania and Russia in the early twenties of the past century by Ivan E. Voronaev, founder of the First Russian Pentecostal Church in New York in 1919."

⁵ The greatest Pentecostal local church communion in the world is in South Korea. It is Yoido Full Gospel Church in Seoul; it has more than 800,000 members; it has its own state-acknowledged university and publishes its daily paper selling million copies.

tion of Pentecostal Churches as a common world network of Pentecostal churches.

Already an extensive literature has been collected about the activities of the most populous component within the evangelistic booming in the world with hundreds of millions of followers from virtually every world region (Anderson 2004; Korten 2001; Cox 1995; Martin 1990; 2002; Nazo 2006; Hunt 2003). Moreover, the demographic center that all the Pentecostals gravitate toward has shifted from the Western countries to Africa, Latin America and some parts of Asia. More and more of South Korean and Latin American Christian missionaries are in Africa as well as African Christians who re-evangelize Western Europe and North America (Бејеп 2010). "Christians in Africa, in 1900, made up only one tenth of the population while today they form 46%... Among the ten most populous Christian states are only three European countries – a century ago there were nine. Nigeria and former Zaire are on the ninth and tenth place while in China there are more Christians than in the united Germany. Data about population growth suggest that, in 2050, on the list of the ten most populous Christian countries there will be not a single European state – the place of Germany and Russia will be taken by Uganda and Ethiopia (Ђирјаковић 2011, 62-3)."

The leading experts on the evangelical boom are drawing attention to its *organizational simplicity* that comprises: *easy carrying* (it is focused on the contents rather than the places of worship), *transmission* (converts themselves take up the role of evangelizers) and *accessibility* (informal atmosphere, emotionally harmonious community and individual acts of the Holy Spirit) (Nazo 2006).⁶

Pentecostalism in Serbia

A married couple, Franjo and Žužana Racz, baptized in the Holy Spirit in Beška (Croatia) moved, in 1936, to Subotica and brought with them a whiff of Pentecostalism („malokršteni“ or

⁶ On theological and cultural causes of Roma Protestantization in Serbia in Todorović 2012b, 2013, 2014a.

baptized infant). The movement spread to Zrenjanin and other cities in Vojvodina and finally to Zemun and Belgrade.⁷ On the eve of the Second World War there were more than 20 Pentecostal communities and groups divided among German, Hungarian and Serbian population (Бјелajaц 2010, 161).

The postwar period was characterized by almost dying away of the German speaking population due to its moving out together with the German army, expulsions and forcing people into military and labor camps. One name stands out, that of Dragutin Volf, an influential preacher in Novi Sad's Church, who was the President of the Pentecostal Assembly for many years. In the fifties, after an initiative launched to unite the Infant-baptizing Church, the Adult-baptizing Church and the Footwashing Spiritual Church, the Christ's Spiritual Church in FNRJ (the Federation of the People's Republic of Yugoslavia) was officially registered with the authorities; it was later renamed into the Association of Christ Spiritual Churches. Its poor hierarchical structure, along with endless rivalry of charismatic leaders, caused new divisions and spilling-over of the members in the following decades.

In the fifties of the twentieth century a church was founded in Karanovac while in the sixties established were communities in Lebane and Leskovac; renewed were activities in Kruševac otherwise initiated in 1942 when Smilja Beljin married Jovan Martić (Бјелajaц 2010, 175). After 1963, groups were formed in Vojlovica near Pančevo, Bela Crkva, Plandište, Pančevo, Kragujevac (1968) and Sombor (1966). The first Pentecostal Church in Kosovo started its activities in 1985 (Бјелajaц 2003; Kuzmič 2007, 228).

On the eve of the breakup of the Socialist Federative Republic of Yugoslavia (SFRY), in the late 1989, at the church synod of Christ Pentecostal Church and Christ Spiritual Evangelical Church in Belgrade, it was decided that the official name of the church should be Evangelical church in SFRY which, as it was

⁷ Arapović (2003, 109) mentions how one of the most important representatives of the Croatian Pentecostal movement, Pet ar Dautermann, between 1938 and 1944, passionately evangelized between Novi Sad and Belgrade thus contributing to the foundation of the first Pentecostal church of Adult-baptizing in 1932 in the capital of Serbia.

soon found out, was not sufficient for establishing so much sought-for unity. In the nineties, the first Neo-Pentecostal (Charismatic) communities also started their activities (Calvary Chapel, Community of Faith, Addiction Treatment Center Crossroads, Christian Community "New Horizon"). Finally, different Pentecostal churches in Serbia changed their name, in 1998, into Protestant Evangelical Churches (PEC). Today their number is estimated to be between seven and eight thousand.

Pentecostals in Southeastern Serbia

A small number of believers in the area of Lebane held their original meetings in the village of Šumane, half-way between Lebane and Gornji Vranovac in a modest village house of Slobodan Stanković.⁸ Impassioned villagers, orchestrated by the State Security forces, on two occasions demolished the pulpit and forced the believers to move to Lebane, to the home of Vera Ranđelović, born Stanković. At the time two additional church premises were added, while in the early eighties another separate building was erected at 16 Pane Đukića Street; it is still today the place of common Sunday church service of Serbs and Roma (Roma in a greater number).

The first evangelical Christians in Leskovac, apart from Vera Davidović, were the married couple Mitković, Ćirilo and Mirolava. Ćirilo later becoming the first pastor in Leskovac, and as he grew old, he retreated to the service in Lebane, while in 1976 ordained for pastor was Miodrag Stanković. In 1964, a building was purchased at 22 Maksima Gorkog Street while an old pre-war villa was also acquired in the early 1980s, which was the family home of the trader Dimitrijević, at number 21. The old building at number 22 had served for Roma religious service before a tent was set up in the "Slavko Zlatanović" quarter, a dona-

⁸ Precious facts about the beginnings of the religious organizing in Southeastern Serbia were given, in a special interview, by Stefan Stanković, a younger son of the founder of Pentecostalism Miodrag-Mija Stanković (Mija's sudden death on February, 24, 2009, just before the scheduled interview in Leskovac deprived us of many authentic evidence about what the preaching of the Biblical doctrine looked like almost half a century ago).

tion from the French Roma Sinti, well known across Europe as the “Church under the Tent”. In 2005, the church was divided into the Protestant Evangelical Church “Community of Roma” and the Spiritual Centre of the Evangelical Church “Light”. Since 2007 the Chinese believers have also started to hold their religious services at the “Light”.

It is a multifunctional center, equipped for proper responses to various needs of the believing population. There is a refectory and a room for daily recreation, a sleeping room with a dozen beds for guests, radio station “Šalom Romalen” for broadcasting programs of spiritual character and a meeting room.

The germ for activities of the Holy Spirit in Niš was an effort invested by Miodrag Stanković from the early seventies of the twentieth century into a sort of parallel support to reinforcement of Niš, Leskovac and Kruševac communities. Another also modest in its contribution was an attempt by pastor Goran Maksimović from the first half of the last decade of the twentieth century. Established formally was the Evangelical Church “Good News” in 1996 while the building at 82 Episkopska Street it got into its ownership not earlier than 2005. The core of the believers at the services was initially made up of some thirty of former students – today the community has about forty baptized believers, mainly Serbs.

Roma Pentecostals in Southeastern Serbia⁹

In Serbia, likewise, the transformation of the Roma minority religious-confessional status in the majority religions into the majority presence in the minority religions and religious communities is the most evident in the example of Evangelical Pentecostalism (Đorđević 2005).

In Leskovac, the first Roma family that have received Christ was that of the Roma woman Sevda, a servant in the household of Ćirilo Mitković. Back in the sixties of the past century Mitković was a Pentecostal pastor. A rare picture was it,

⁹ More detailed in: Тодоровић 2012а.

even for today, let alone for that time: Serbs and Roma at the same table having a Sunday lunch; this led Sevda to the lasting decision to permeate her own life with faith and prayer and with her own impeccable behavior interest her numerous compatriots in a new Christian teaching (Тодоровић 2011а).

Yet, more than the Biblical morals, drawn to Pentecostalism were Roma by the *prayers for health* of Miodrag Stanković when he, in the mid-seventies of the past century, took up the leadership of services and church in Leskovac. Even he himself, as a young pastor, at one point exhausted with sickness, was always ready to respond to Roma' needs, physical or spiritual, individual or familial.¹⁰ All over *mahalas* in Leskovac it was widely rumored that "the Church is healing the sick," that is, that the elders' devout prayers for healing were more efficient than official medicine. The elders themselves, however, interpreted all this more like God's response to the believers: children to the infertile, a male heir to the family, cleansing of tumors and growths on the body and the like. In any case, groups of Roma from the city quarters of Podvorac, Sat-mala and new "Slavko Zlatanović" settlement crowded on Sundays before the building at 22 Maksima Gorkog Street (picture 1) and made the authorities in the Church launch a "mission in the mission," that is, formation of a separate "Community of Roma". This Community later brought forth many others in its immediate surroundings, urban and rural.

As already noted, an important year in the religious life of the Roma Pentecostals in the city on the Dubočica River (Leskovac) is that of 2005, when a third of the believers, headed by their leaders, Šerif Bakić and Bojan Ristović, came back under the wings of the Serbian community "Light", while the others went on being represented by Selim Alijević. This split directly caused separate formation of new communities under the auspices of the Spiritual Centre of the Evangelical Church "Light" and the Protestant Evangelical Church "Community of Roma" (Kurtić 2003, 2008).

¹⁰ Consult authentic testimonies of Miodrag Stanković, published in Stanković 2007, as well as the Starešinstvo Protestantske evanđeoske crkve (Elders of the Protestant Evangelical Church) 2007.

The “Community of Roma” is more agile in its missionary work. Small prayer groups and mission stations can be also found in Prokuplje, Surdulica, Vladičin Han, Bela Palanka, Piroć, Bujanovac as well as in Žitni Potok, Razgojna and Pečenjevac, including Dubovo near Bojnik. Gatherings are most often in some believer’s home, periodically visited by the elders from Leskovac. In Prokuplje the believers are led by Marjan Stanković, second year student of the Biblical School, that the Leskovac headquarters seriously counts upon in his future evangelistic work.

Depending on the modest financial means and resourcefulness of the believers themselves on the spot, some communities started to work either in rented or their own facilities. Thus, for instance, close to Leskovac is Bošnjace where, in the Roma *mahala* in the centre, there is a rather small building enabled, with the basic construction efforts, for gatherings of some thirty Roma led by Nenad Durmiširević.

Special attention is devoted to contacts with brothers and sisters in neighboring Vranje which already started in the early nineties of the twentieth century. The elders, Dalibor Jašarević and Nenad Bektašević, are at the disposal of the converted to Christ while the premises were voluntarily given over by Jovica Jašarević. They have also initiated a Church site at: <http://romsk-acrkva.com>.

The religious needs of some fifty Roma from eight kilometers far away Vranjska Banja are also fulfilled. Basically, is equipped for religious service an attic of the family home of Kadira Asanović (picture 2).

In Vranje and Vranjska Banja are also active branches of Leskovac Spiritual Centre of the Evangelical Church “Light.” In the old city core, in Upper Čaršija, only a few dozen meters from the monument to Bakija Bakić, father of the Roma trumpet, in a rented room on the ground floor of a family building some thirty Roma Pentecostals organize their gatherings (picture 3).

Also rented is a room in Vranjska Banja to which come to listen to sermons and praise God some twenty believers.

As a separate community, in a *mahala* at the Jewish cemetery in 11 Mramorska Street, the Protestant Evangelical Church, the Spiritual Centre “Community of Roma,” functions with

around thirty baptized believers and around one hundred sympathizers (picture 4). Elder Rama Jašarević, with his wife and children, lives in a house near the Church; he does not come from Niš originally; he has moved from Leskovac in order to conduct his mission among his compatriots in the city upon the Nišava River (Niš).

Protestant Evangelical Church “Community of Roma” in Leskovac

21st of September 1986 is a historical date for Evangelical Pentecostalism in Serbia. On that day, in Leskovac, sanctified are objects of the Spiritual Centre of the Evangelical Church “Light” in Maksima Gorkog Street; likewise, the first “Community of Roma” in the former Yugoslavia was opened (Starešinstvo Protestantske evanđeoske crkve 2007). One church but two communities in two objects: Serbian at number 21 while Roma at number 22.

Many have, in those days, estimated as a risky step the division of religious service into Serbian and Roma languages afraid of the judgment for division in Christ of two nations. However, there are, amongst them, those who were firmly convinced that Roma deserve to express their achieved spiritual freedom fully in accord with their own temperament. Like in other important living situations, they would utterly give themselves to the Church events. Their articulation of whatever was felt in their souls was not the same as with their Serbian brothers: faster, louder and noisier was their singing; they prayed more passionately; they stood clapping their hands; they raised their hands as well as eyes toward the ceiling. The verses copied from the Anglo-Saxon hymn books were composed in accordance with the well-known Roma music; their lyrics were a specific experience of God in their own language. Although they still lacked their own state, they became fully equal members of the Kingdom of God. They got their own church and a completely new identity. In a word – they praised God in their own Roma way!

After completing two year-spiritual education in the International Bible Training Institute in Burgess Hill in England, Miodrag Mija Stanković and his sons, Stanko and Stefan, in 1991 were joined, as elder and then as the first Roma pastor young and promising Selim Alijević (Kurtić 2003). In the early two-thousands ordained as elders are Šerif Bakić and Bojan Rasimović. The team work has given immeasurable contribution to active spread of the Gospels among Leskovac Roma. In the times to come, the number of the baptized believers has exceeded thousand along with at least as many friends of the Church and occasional visitors.

Children, teenager and youth lessons, in addition to later sisters' ones, enabled the whole generation of new believers, enthusiastic enough to tirelessly call people, in the narrow and overcrowded alleys in the *mahalas*, to come, at different terms, to Sunday religious services since not all of them possibly could be contained in such a small space. The problem was in the main resolved on April 1, 2001, when a big blue-white tent¹¹ was set up (25x15 m in size), on the bought parcel at 35 Karađorđeva Street, in the "Slavko Zlatanović" settlement (a yard of the former warehouse of the company "Dva jarana" /"Two Pals"/) (picture 5).

Though the registration of religious gatherings at a new address was properly done at the respective institutions, this was not the whole story. Very frequent objections on the part of the neighbors of Serbian nationality at the entrance of the street as well as a wider area because of alleged noise and improper behavior culminated in the resolution brought by the communal authorities ordering the tent to be disassembled or torn down. The elders responded wisely by informing all available printed and electronic media about violation of the civic and religious freedoms and by forming a "living shield" before the object formed of over a thousand young and old believers along with the youngest children. A sermon was held in the open; there was much singing to God and praying to Christ. The Presi-

¹¹ Leskovac Roma are by no means an exclusive case. Unable to accommodate thousands of new believers who come to hear sermons about "God on earth", Brazilian pastors are all the time forced to rent big blue-white circus tents (Ђирјаковић 2005, 66).

dent of Leskovac Municipality did not want to risk his public reputation, so that a compromise was made to calm down the passions and provide for the tent survival (Kurtić 2008). At the same time, the premises at 15 Maksima Gorkog Street were turned into a humanitarian storage, that is, the seat of the Charity Society "Oasis".

Just as one storm died down, another started. Due to the opposed views regarding the future church organization – though church indiscipline was also mentioned – in the early 2005 a split occurred within the so far united "Community of Roma". Under the same name and leadership of pastor Selim Alijević, member of the Main Elders and coordinator of the Roma communities of the Protestant Evangelical Church in the Socialist Republic of Yugoslavia (SRY), a larger group of Roma remained while a smaller group, headed by Roma elders Šerif Bakić and Bojan Rasimović opted for, or rather, returned to its original nest - Spiritual Centre "Light" and common religious service with Serbs at 21 Maksima Gorkog Street. Regarding its structure, the "Light" defined itself as an independent church commune in the South of Serbia, independent of Belgrade.

Confidence was shaken of a quite numerous population of believers. Some of them suddenly decided to stop attending both the communities; in silence and without many words they expressed their dissatisfaction with the reorganization. Moreover, the whole families were also shaken: Father chose Selim unlike son who chose Šerif thus heating up tensions within the family circle. Assistant to Selim Alijević, Goran Saitović, confirms that today's community gathers together some three hundred of baptized believers and as many friends (this proportion also stands for the Center "Light").¹²

The Church in the new settlement has continued to develop. In addition to the tent, gradually are repaired the existing buildings of firm material for performing all sorts of activities. Today's existing complex includes an administrative office, a

¹² While conducting planned interviews, I could conclude, from the talks I had with common believers from both the communities, that there is general mood for re-establishing the previous unity. It seems it is upon the Church elders to find a practical way of doing it for the benefit of all.

classroom with the school equipment for work with the young ones, a kitchen for refreshments and snacks, recreational facilities and a radio station.

The main part of the Church activities in the “Community of Roma” is done in the Roma language, from regular religious service to religious training with the youngest ones. If non-Roma come as guests to the service, it is an unwritten rule that the pastor should preach in Serbian. An hour before the habitual schedule for religious service – on Wednesdays and Sundays from 6 pm – the first believers come to a spacious churchyard; those from far away *mahalas* or places gravitating to them, as well as older and people with motion sickness have a rented van at their disposal. The attendance is better on weekends, as a rule, before the coldest season when Roma are returning from autumn seasonal jobs all over Serbia to spend the winter in their homes. At the entrance of the Church there are monitors and deacons, servers responsible for organizing and conducting church rituals: after greeting each member individually, they direct people to the central part of a spacious hall. The inner walls of the tent are covered in wood panels in order to maximally preserve warmth when the snow starts to fall.

Uninformed and unprepared observers are liable to face an unusual scene while the last arrangements are being made on the stage: some believers take turns in loud emotional expressions of prayers to God before other brothers and sisters. The padded wooden benches are mainly taken by women both older ones, hunched-backed and with head coverings, as well as younger ones, with no scarves, very often with babies in their arms or holding the hands of their several years old children. Their own place at one end is reserved for children attending primary and high schools. The clothes the believers wear is far from the glitter and quality of the attendants of the religious services with Adventists and Jehovah’s Witnesses; they are not new, yet they are clean and tidy. The first central row, just opposite to the raised stage with a sound system and musical instruments, is usually intended for guests and leaders. Evident attention is devoted to the members of musical accompaniment, i.e., keyboards, goblet drum, guitar and bass guitar, with a separate

microphone for accompanying vocals of singers. An especially appointed young man is to deal with a laptop; on a stretched canvas on the wall he keeps on changing lyrics and biblical quotations otherwise mentioned in the pastor's sermons and prayers – this is to serve all those who have not been well acquainted with the Holy Scripture.

One or two songs of pious contents are enough to establish the oneness of spirit of those in the hall before pastor Selim Alijević, with a microphone in his hand, offers words of welcome and invites, with his opening prayer, all the present to join a common address to Christ, so-called *praise of God*. What follows is a set of songs of recognizably Christian contents in the harmonies of Roma music. Enchanted, with, as a rule, their eyes closed, the believers express the pouring of the Holy Spirit; some of them are sitting; many are standing up; some hands are in the air while some other people have folded their arms across the chest or let them hang loosely; some voices are thundering while others can hardly be heard uttering verses; some faces are all in tears streaming down both cheeks or with faces twisted into pain grimaces; some others are perfectly calm. Everything is subordinated to the personal experience sustained by blasting music powerfully resounding from the loudspeakers. On special occasions comes a church choir thus completing, together with the musicians, the team for praising God. Already a few CDs with the Roma spiritual music have been recorded and freely distributed.

After the ritual of praise, the believers listen to a sermon from the Bible with a clear moral message. The pastor is reading verses in Serbian though he clarifies and elaborates them in Roma. What follows is another set of songs and, before the ending of the evening service, there are prayers for the needs of the believers. In a murmuring crowd going out into the night one can spot one or two mothers with babies in their arms or some wretched accompanied person asking the pastor to say words of blessing directly to him.

A few times a year, regularly on the Day of Pentecost, baptized are new members from Leskovac and smaller places in which the Church has its believers.

The pastor is aided, in his work, by the Church Board appointed once a year. It is made up of distinguished Church representatives who confirm, by indicating the changes in habits, a beneficial effect of Christ on them. Further functioning of the assigned tasks is also contributed by numerous other assistants: religious training instructors, filing clerks on duty, sister leaders, prayer coordinators, leaders of charity work, etc.

Since 2009, there has been a kindergarten functioning in the Church; together with its Sunday school it plays a decisive role in teaching the youngest moral and spiritual values. There is also a four-term DVD Biblical School whose conception is to inform about the foundations of faith; the completion of this school implies the acquisition of diploma and recommendations for further religious improvement. Since 2005 the radio program of local range broadcast Radio Emanuel at 98,2 megahertz; it transmits sermons alive, readings from the Bible and spiritual music in the Roma language. In the Union Hall in Leskovac it has already become a tradition in the last few years to organize celebrations devoted to Christmas and Easter along with the performances of youth choir, amateur drama groups and children groups. Permanent Internet page is formed at: <http://zajednicaroma.com/php/show.php>.

Present State and Perspectives of Roma Pentecostalism in Southeastern Serbia

After their initial mutual misunderstandings and oppositions, *Roma evangelical pastors have become synonyms for desirable partners of the municipal authorities in solving piled up problems of Roma*. The reasons for this are their ensuring of an intense cooperation with “non-Roma” based on their common interests: lowering of the crime rate, improvement of family relationships, a new attitude toward the sphere of work and production and the like. By their caretaking and serving among the believers, still, the ordained leaders advocate general religious values identical to the secular ones: justice, freedom, truth, rule of law, and struggle against rising discrimination.

Neither do Non-Roma and Roma leaders of evangelical Christians refuse to get involved in politics.¹³ With their responses they make it clear they do not like either leftist or rightist deputy mandates since the mission of the Church and the messages from the pulpit are far beyond narrow-mindedness and selfishness of the games of political rivalry. How to be cautious they also learnt from the experience they gained so far, mostly negative, with the actors of Serbian parliamentarism though the believers are not prohibited to have their votes at elections. Yet, they do care to have, in the commissions that make decisions about the issues of vital city functioning (communal and traffic problems, development plans, social programs, culture and education), the persons with outstanding moral integrity. Two reasons are for this. People who have received Christ in their lives and who whole-heartedly love God would suppress corruption, murky dealings, lies, thefts and cheatings; they would use their moral integrity to affect others to bring themselves to decency in accordance with the basic Christian principles. At the same time, they could present, to relevant city authorities and bodies, all the problems of the Roma people in the local community thus contributing to their welfare.

Pentecostal Spiritual Centre "Light" in Leskovac has been patiently, for many years, in cooperation with city structures, planning and projecting the construction of a multi-functional object at three and a half hectares in the "Slavko Zlatanović" settlement-*mahala* that is to meet the needs of spiritual and cultural life of Roma as well as other citizens of Leskovac. Roma pastor, Selim Alijević has confirmed to us that the Protestant Evangelical Church "Community of Roma" in Leskovac is getting ready to launch an initiative for founding an *alliance of Roma churches*. The idea is to gather together under one roof all the evangelical churches representing Roma converts to Christianity, so that they could sustain each other in their missionary work.

Thus, the religious communities attain, with their activism, two goals, namely, they foster desired public political cohe-

¹³ A more comprehensive account of the achievements of political activism among Roma Pentecostals in Southeastern Serbia in Тодоровић 20146.

sion and credibility of Roma representatives and they ensure lasting support of a wider society. For now, domestic evangelists should not be expected to appear in the roles of founders or sponsors of political movements or parties; a greater likelihood is the appearance of Roma Pentecostals in the role of creators of “public role” of evangelical Christianity in their respective local neighborhoods. The most typical are religious institutions that serve for other purposes apart from religious ones with the intention to represent and involve the Christianity of the “re-born” into the common cultural space.

Time will show whether the Pentecostal religious leaders in Serbia will undertake open political awakening of Roma people and thus widen the range of their activities that would serve as guides to new believers in making their choices on the religious market. *For the time being, this is not the case yet.*

Photos:



Picture 1: Spiritual Centre of the Evangelical Church "Light" in Leskovac (May 2007)



Picture 2: Sub-branch of the Protestant Evangelical Church "Community of Roma" in Vranjska banja (February 2009)



Picture 3: Sub-branch of the Spiritual Centre of the Evangelical Church "Light" in Vranje (March 2009)



Picture 4: Protestant Evangelical Church "Community of Roma" in Niš (March 2009)



Picture 5: Today's Outlook of the Church under the Tent" in Leskovac (February 2009)

Literature

- Anderson, Allan. (2004). *An Introduction to Pentecostalism: Global Charismatic Christianity*. Cambridge: Cambridge University Press.
- Anderson, Robert M. (2005). "Pentecostal and Charismatic Christianity." In *Encyclopedia of Religion*, second edition, vol. 10, editor and chief Jones Lindsay, 7028–034. Detroit, MI: MacMillan Reference.
- Arapović, Borislav. (2003). *Njihovih tragom (Prvi pentekostalci u Hrvatskoj)*. Osijek: Izvori.
- Бејер, Питер. 2010. Религија и глобализација. Теме 34 (4): 1295–1316.
- Бјелајац, Бранко. (2003). Протестантизам у Србији (Прилози за историју реформацијског наслеђа у Србији – I део). Београд: Алфа и Омега.
- . (2010). Протестантизам у Србији (Прилози за историју реформацијског наслеђа у Србији – II део). Београд: Сотериа.
- Jambrek, Stanko. (2007). Riječ urednika. *Kairos* 1 (2): 183–84.
- Korten, Andre. (2001). „Eksplorzija pentekostalnih crkava.“ *Le Monde diplomatique* Decembar: 19.
- Cox, Harvey. (1995). *Fire from Heaven – The Rise of Pentecostal Spirituality and the Reshaping of Religion in the Twenty-first Century*. Reading, Massachusetts: Addison-Wesley.
- Kuzmič, Franc. (2007). „Pregled povijesti pentekostnog pokreta u Jugoslaviji od početka do 1991.“ *Kairos* 1 (2): 221–34.
- Kurtić, Tane. (2003). "Protestant Evangelical Church 'Community of Roma' in Leskovac." In *Roma Religious Culture*, edited by Dragoljub B. Đorđević, 177–84. Niš: YSSSR, Yuroma center and Punta.
- . (2008). „Протестантска Еванђеоска црква 'Заједница Рома' у Лесковцу.“ Лесковачки зборник XLVIII: 351–58.
- Marinović Bobinac, Ankica. (1999). „Urbanost pentekostalnih zajednica: Socio-demografska obilježja zagrebačkih pentekostalaca.“ *Sociologija sela* 37 (4): 407–27.
- Martin, David. (1990). *Tongues of Fire: The Explosion of Protestantism in Latin America*. Oxford UK and Cambridge MA: Blackwell Publishers.
- . (2002). *Pentecostalism: The World their Parish*. Oxford: Blackwell.
- Nazo, Paolo. (2006). „Izazov pentekostalaca.“ *Limesplus* 2–3: 89–97.
- Stanković, Miodrag. (2007). „Romi – nasleđstvo od Gospoda.“ *Religija i tolerancija* 7: 171–72.
- Starešinstvo Protestantske evanđeoske crkve. (2007). „Dvadeset godina 'Zajednice Roma' u Leskovcu.“ *Religija i tolerancija* 7: 173–76.

- Тодоровић, Драган. (2011). „Протестантизам на Балкану и у Србији“. *Социолошки преглед* 45 (3): 265–294.
- . (2012а). „Етнографско-социографски показатељи раширености протестантских верских заједница у југоисточној Србији (са посебним освртом на Роме протестанте)“. *Етнолошко-антрополошке свеске* 19: 87–111.
- . (2012б). „Улога културних фактора у protestantizацији Рома југоисточне Србије.“ *Kultura* 136: 376–402.
- . (2013). „Суштина верског учења као богословски фактор протестантизације Рома југоисточне Србије.“ *Култура* 141: 53–72.
- . (2014а). „Улога богословских фактора у протестантизацији Рома југоисточне Србије.“ У Прилози стратегији унапређења положаја Рома, приредили Тибор Варади, Драгољуб Б. Ђорђевић и Горан Башић, 113–136. Београд: САНУ и Заштитник грађана Републике Србије.
- . (2014б). „Стање и перспективе политичког активизма међу Ромима пентекосталцима у југоисточној Србији.“ *Теме* 38 (3): 999–1018.
- Ђирјакковић, Зоран. (2005). „Станиште сина Божјег, тамна страна“. НИН 2852, 64–68.
- . 2011. „Христ станује у Нигерији.“ НИН 3132: 62–4.
- Hunt, Stephen J. (2003). *Alternative Religions: A Sociological Introduction*. Aldershot: Ashgate.

YURI STOYANOV
School of Oriental and African Studies
University of London

Contemporary Alevi and Bektashi Religiosity in Turkey and the Balkans - Traditional Forms and Postmodern Expressions

Abstract

In this paper, the author will be examining the different varieties and expressional forms of the contemporary Alevi/Bektāşī religious identity in modern Turkey and the Balkan countries, with an overview of its historical development spanning from pre-Islamic Central-Asian and neighbouring Christian influences to the XIX and early XX century Ottoman and subsequent Balkan Slavic nation-building policies. With a reference to a vast theoretical and research background, it also sheds light on the syncretic and heterogeneous nature of Bektashi identity and also the contemporary identities of both the Bektashi diaspora and the population of the aforementioned regions. From a theoretical standpoint, the paper also points out the significance of some newly conducted interdisciplinary research that specially focuses on the Anatolian and Balkan communities. Finally, it is noteworthy that, due to modernization processes and urban migrations, a rise of secular, "progressive" and left-leaning elements within these communities has been noticed since the '60s and '70s. Such views are sometimes seen as opposed to religious traditionalism of the Bektashi, and sometimes complementary to this groups universalist values.

Keywords: Post-secularism, Heresy, Heterodoxy, Islam, Christianity, Orthodoxy, South-East Europe/Balkans, Ottoman Empire, Alevism, Bektāşīsm, Sufism, Syncretism, Religious Conversion, Slavonic Cultures, Turkic Cultures, Post-Ottoman State/Nation-building.

■ Since the late 1980s a number of publications in the areas of Turkish, Ottoman, Balkan and Islamic studies (and adjacent fields) have treated various facets of modern and post-secular Alevi and Bektāşī religiosities in Turkey, South-East Europe and in diaspora

communities in Western Europe and North America. Such publications have added much new material and observations to the ongoing disputes regarding the diverse spectrum of teachings and practices which could be approached and defined as Islamic “heresy”, “heterodoxy” and/or “gnosis”, in both earlier historical, and contemporary religiopolitical contexts.

Such controversies and debates have been especially prolonged and animated in the case of Alevism and Bektāšism. “Alevism” eventually came to be used as an umbrella term for the initially diverse Anatolian and Balkan non-conformist and Shi’ite-oriented and/or -influenced ethno-religious communities which originally were designated with another generic term, *Kızılbaş*. On the other hand, while the rise and the formative stages of the *Bektāšīyya* still pose series of unresolved questions, eventually it came to be recognized and operated until 1826 (the year when it was officially suppressed and abolished) as one of the principal Ottoman Sufi orders (*ṭarīqat*). The trajectories and tenor of these debates have been affected by the specific interplay between traditional/inherited and more recently ascribed Alevi and Bektāšī identities in Asia Minor and the Balkans which has followed some complex courses since the late Ottoman period. The abiding complex of Sunni learned and popular negative stereotypes regarding Alevism, stemming from earlier formulated Sunni confessionalist anti-Alevi/*Kızılbaş* (and frequently discriminatory) attitudes and discourses, has also played a substantial role in this process.

What is more, the characteristic and continuing Alevi revivalism in Turkey and the Alevi diaspora in Europe during the last three decades or so, has evolved also in the general context of the advance of the Sunni-based unitarian *Türk-İslam sentezi* (“Turkish-Islamic Synthesis”) project of the 1980s and the related progress of and increasing electoral support for political Sunni Islam in Turkey. Consequently, the main topics of the continuing disputes regarding Ottoman-era and post-Ottoman Balkan and Anatolian (and lately West European diasporic) Alevism concern the traditional, received and reconstructed Alevi markers of identity/ies. Apart from the central question of the place of Shi’ism in Alevi teachings and rituals, a parallel set of arguments and theories have been trying for some time to detect discernible influences of pre-and non-Islamic

religious trends on Alevism and Bektāšism. The spectrum of such proposed influences has been rather wide-ranging, from pre-Islamic Turkic Central Asian or Iranian and Kurdish beliefs and customs to Eastern Christian (Armenian, Greek or Slavonic - orthodox, heterodox or heretical dualist) doctrinal and cultic traditions. Such range of perspectives and potential impact clearly necessitates interdisciplinary research approaches to the eclectic variety of teachings and ritual practices constituting a religious tradition which has been frequently defined as highly syncretistic.¹

Likewise with other Near Eastern syncretistic and heterodox religious traditions as those represented by the Yezidis and Ahl-e Haqq, Alevi/Bektāšī syncretism has been categorized and explored as a conglomerate structure,² with various components of varied date and provenance which need to be stratified before one can “separate” the oldest and core strata.³ The various advanced identifications of the foundational layers in Alevi/Bektāšī syncretism, naturally could reflect different, even contrasting ethno-confessional and ideological perspectives. Such perspectives have accordingly variously prioritized as defining and earliest components ancient Anatolian, pre-Islamic Turkic/Central Asian shamanistic traditions, Shi’ite- and Sufi-related trends, Iranian religious currents (especially in Kurdish- and Zaza-speaking Alevi milieu) or have fo-

¹ The phenomenon of “Alevi/Bektāšī syncretism” has been methodically investigated in a number of studies of Irène Mélékoff, series of of which have assembled in her volumes of selected articles: *Au banquet des quarante: exploration au coeur du bektachisme-alevisme*, Istanbul: Isis, 2001, and *Sur les traces du soufisme turc: recherches sur l’Islam populaire en Anatolie*, Istanbul: Isis, 1992; as well as in her monograph, *Hadji Bektach: un mythe et ses avatars: genèse et évolution du soufisme populaire en Turquie*, Leiden: Brill, 1998.

² For an important early reconstruction and examination of such “conglomerate-like” belief system, in the case of the Ahl-e Haqq, see Vladimir Ivanov, *The Truth-Worshippers of Kurdistan: Ahl-i haqq Texts* (Bombay: Matḥa’i Qādirī, , 1950), 31-75 (in which the different strata of this structure are accordingly identified as archaic animism, solar cult notions, popular Mazdaism, Christian sectarian lore as well as Islamic Shi’ite Ismaili and Safavid-related layers).

³ The most systematic application of such stratification approach can be found in Irène Mélékoff’s studies of Alevism and Bektāšism; see especially Irène Mélékoff, “Recherches sur les composantes du syncrétisme Bektachi-Alevi”, repr. in *eadem*, *Sur le traces du soufisme turc*, 41-61 and *eadem*, *Hadji Bektach*, ch. 4.

cused on a posited formative Eastern Christian impact - Armenian and Greek in Asia Minor and/or Greek and Slavonic in the Balkans.

The distinct diversity of perspectives and discourses on historical and contemporary Alevism reflects to some extent some of the divergent and often conflicting tendencies and agendas evident in the early research on Alevism and Bektāšism. The early study of Alevism and Bektāšism could not avoid the impact of the nation-building and confessional ideologies, developing initially in the Balkans, then in Kemalist Turkey, amid the spreading political conflicts of the late Ottoman and early post-Ottoman periods. Many of the principal early Western accounts of Alevi and Bektāšī beliefs and practices, some of which were produced by actual missionaries, betray explicit or inherent theological and missionary stances and priorities.⁴

Subsequently and especially over the last few decades research on Alevism and Bektāšism has expanded based on the evidence-oriented exploration of diverse primary sources in state or private archival collections which increasingly has been made available in general and critical publications and translations. This primary source material comprises the *Menakīb-nāmes* and *Vilāyet-nāmes* of important Alevi and Bektāšī sacred protagonists; the manuscripts of the two versions of the Alevi doctrinal-catechistic work, the *Buyruk*; the *Maqālat*, the “sayings” attributed to the reputed founder of the Bektāšī order, Hacı Bektaş Veli (c. 1300), the religious hymns, *nefes*, and other diverse written record. Ground-breaking art-historical, architectural and some archaeological investigations (focused on inscriptions, funerary stele and iconography) have been conducted at several the most significant Alevi and Bektāšī religious and cultic sites, *tekkes*, *zaviyes*, *türbes*, etc. in Asia Minor and the Balkans.

⁴ For Protestant missionary approaches to the Alevism, see Ayfer Karakaya-Stump, “The Emergence of the Kizilbas in Western Thought: Missionary Accounts and their Aftermath”, in *Archaeology, Anthropology and Heritage in the Balkans and Anatolia: the Life and Times of F.W. Hasluck, 1878-1920*, ed. David Shankland, (Istanbul: Isis, 2004), vol. 1, 328-353; Hans-Lukas Kieser, “Muslim Heterodoxy and Protestant Utopia. The Interactions between Alevism and Missionaries”, *Die Welt des Islams*, n. s., 41:1 (2001): 89-111.

The progress of inter-disciplinary, ethnographic and anthropological work among Balkan and Anatolian Alevi groups (and those who self-define themselves as affiliated with Bektāşism) has explored and opened new avenues of study in core Alevi beliefs and cultic observances. Thus, fresh light has been shed on the mechanisms of internal control and oral circulation of knowledge within the Alevi community, from religious lore and narratives to the mediation of religious authority within the characteristic hereditary religious leadership, the *dedelik* or related or relevant Sufi *silsilas*. The nascent history of *Kızılbaşism* and Bektāşism still poses a number of convoluted religious and historical problems, some of its phases have been illuminated by fresh analyses of Bektāşī-related historiography, polemics, hagiography and early shrine complexes and Bektāşī interlinkage with contemporaneous antinomian dervish groups (Çalenders, Abdâls of Rûm, Hâyderîs, Câmîs and Şems-i Tebrîzîs) and their eventual integration into the Bektāşī networks in the sixteenth century.⁵ More progress has been accomplished in the area of evolution of *Kızılbaşism* and Bektāşism in the classical Ottoman period, including the post-sixteenth century patterns of *modus vivendi* reached between the various Anatolian and Balkan *Kızılbaş* communities and the Ottoman central and local establishments and the arguable role of the Bektāşī order in these processes.⁶

These significant developments in research have not been consistently echoed or considered (or could be indeed distorted) in the continuing socio-religious polemics on the historical and contemporary religiopolitical stances of Alevism and Bektāşism. These

⁵ Ahmet T. Karamustafa, "Çalenders, Abdâls, Hâyderîs: The Formation of the Bektāşīye in the Sixteenth Century", in *Süleyman the Second and his Time*, ed. Halil Inalcik and Cemal Kafadar (Istanbul: Isis, 1993), 121-129; *idem*, "Origins of Anatolian Sufism", in *Sufism and Sufis in Ottoman Society: Sources, Doctrine, Rituals, Turuq, Architecture, Literature and Fine Arts, Modernisms*, ed. Ahmet Y. Ocak (Ankara: Türk Tarih Kurumu, 2005), 67-95.

⁶ See: Surajja Faroqhi, *Der Bektaschi-Orden in Anatolien: (vom späten fünfzehnten Jahrhundert bis 1826)*, Vienna: Verlag des Institutes für Orientalistik der Universität Wien, 1981; *eadem*, "Conflict, Accommodation and Long-Term Survival. The Bektāşī Order and the Ottoman State (Sixteenth-seventeenth centuries)", in *Bektachiyya, Etudés sur l'ordre mystique des Bektachis et les groupes relevant de Hadji Bektach*, eds. Alexandre Popovic and Gilles Veinstein, (Paris: Geuthner, 1995), 167-181.

controversies have initially evolved against the background of the Kemalist modernizing reforms, and lately in the more volatile religious climate created by the expansion of political Islam in the country. The various early Kemalist reforms inevitably had their effect on Alevi socio-religious organization and its hereditary religious leadership, the *dedelik*, and the whole cycle of its traditional religious life centred on the Alevi and Bektāšī cultic sites and the Alevi assembly houses of worship), the *cemevi*. The Kemalist prohibition of the Sufi orders and closure of their convents in 1925, inevitably had various implications for the religious standing of the Alevi religious leaders, the *dedes* and the status of the Alevi and Bektāšī sacred places. Factors such as the wide-ranging impact of migration to urban areas and immigration abroad as well as the growth of secularization brought about the appearance of secularized Alevi élites. These new secularized Alevi circles started to challenge the traditional authority of the *dedes* and in the emerging generational conflicts could utilize novel channels such as journalistic media and literary productions.⁷ The processes of modernization, secularization and immigration also led to the general politicisation and rising popularity of leftist ideologies among the Alevis in the 1960s-70s as well as the subsequent formation and broadening of activism of transnational Alevi associations.

All these processes transformed traditional Alevi/Bektāšī identity politics and its religious aspects. Positions on the left of the Alevi political spectrum emphasize received attitudes based in the perceived historical Alevi anti-establishment and non-conformist stances, shaped in the framework of enduring conflicts with repressive secular and religious authorities. Such stances can concurrently downplay and overlook Alevi religious, spiritual and esoteric

⁷ On the continuing restructuring of the *dedelik* institution in new communal and urban contexts, both in Turkey and among West European Alevi diasporic communities, see: Ali Yaman, *Kızılbaş Alevi Ocakları* (Ankara, Elips, 2006); Martin Sökefeld, "Alevi Dedes in the German Diaspora: The Transformation of a Religious Institution," *Zeitschrift für Ethnologie* 127 (2002): 163–186; Markus Dressler, "The Modern Dede: Changing Parameters for Religious Authority in Contemporary Turkish Alevism," in *Speaking for Islam: Religious Authorities in Muslim Societies*, ed. Gudrun Krämer and Sabine Schmidtke (Leiden: Brill, 2006), 269–294; Özlem Göner, "The Transformation of the Alevi Collective Identity," *Cultural Dynamics*, 17:2 (2005): 122–124.

notions, while developing a rhetoric grounded in popular Marxism and sociologized versions of liberation theology - such leftist ideological schemas could also integrate pro-Kurdish emancipation views and arguments.⁸ Pro-Kemalist currents, rooted in Alevi backing of and participation in the Kemalist modernizing and reformist movement, remain influential in contemporary Alevi political self-consciousness and continue to employ a “progressivist” rhetoric, highlighting a number of parallels between secular modernity and basic Alevi values presented as liberalism, humanism, religious tolerance and freedom of conscience.⁹

These pro-Kemalist and modernist positions co-exist in Alevi socio-cultural sphere of Alevism with more religionist, whether Sunni-leaning or Sufi-oriented circles ostensibly seeking to “standardize” Alevism within the broader framework and legacy of diverse Ottoman Sunni Sufi traditions and orders.¹⁰ Other religionist,

⁸ On these trends, see: Karin Vorhoff, *Zwischen Glaube, Nation und neuer Gemeinschaft. alevitische Identität in der Türkei der Gegenwart* (Berlin: K. Schwarz Verlag, 1995), 102-105; Faruk Bilici, “The Function of Alevi-Bektashi Theology in Modern Turkey”, in ., *Alevi Identity: Cultural, Religious and Social Perspectives*, ed. Tord Olsson, Elisabeth Özdalga and Catharina Raudvere, (Istanbul: Swedish Research Institute, 1998), 52-53; Tahire Erman and Emrah Göker, “Alevi Politics in Contemporary Turkey,” *Middle Eastern Studies*, 36/4 (2000), 99–118 104-105, 108, 110-111; Markus Dressler, *Die alevitische Religion. Traditionslinien und Neubestimmungen* (Würzburg: Ergon, 2002), 124-191 *passim*; Élise Massicard, *L’Autre Turquie. Le mouvement aléviste et ses territoires* (Paris: PUF Proche Orient, 2005), 101-103.

⁹ On these currents, cf. Karin Vorhoff, “Let’s reclaim our history and culture!”— Imagining Alevi community in contemporary Turkey”, *Welt des Islams* 38 (1998): 240-242; *idem*, “Discourses on the Alevi in Contemporary Turkey”, in *Syncretistic Religious Communities in the Near East*, eds. Krisztina Kehl-Bodrogi, Barbara Kellner-Heinkele and Anke Otter-Beaujean, (Leiden: Brill, 1997), 100-101; Erman and Göker, “Alevi Politics in Contemporary Turkey,” 111-112; Markus Dressler, *Die civil religion der Türkei. Kemalistische und alevitische Atatürk-Rezeption im Vergleich* (Würzburg: Ergon, 1999), pp. 83-113 *passim*; *idem*, *Die alevitische Religion*, 224-243 *passim*.

¹⁰ On the Sunni-oriented currents in contemporary Alevism, see: Reha Çamuroglu, “Alevi Revivalism in Turkey”, in *Alevi Identity: Cultural, Religious and Social Perspectives*, ed. Tord Olsson, Elisabeth Özdalga and Catharina Raudvere (Istanbul: Swedish Research Institute, 1998), 81-82; *idem*, “Some Notes on the Contemporary Process of Restructuring Alevilik in Turkey,” in *Syncretistic Religious Communities*, ed. Kehl-Bodrogi, Kellner-Heinkele and Otter-Beaujean, 28-29; Erman and Göker, “Alevi Politics in Contemporary Turkey,” 106.

but less influential, plan and work on changing the sense of direction of Alevism towards a legalist Twelver Shi'ite Islam of the type established in the Islamic Republic of Iran after 1979.¹¹

Post-secular religiopolitical projects and discourses in Turkey after the end of the Cold War (influenced by factors, such as the debacle of Communism in Central and Eastern Europe Eastern Bloc countries, socialist ideologies' declining appeal, the growth of political Islam, etc.) reignited the tensions between the secularizing modernist and religionist trends in modern Alevism. The internal restructuring tendencies within Alevism have already generated designs, aiming to effect a scripturalization and standardization of Alevi doctrinal and ritual traditions, and these efforts have now received further impetus in current cultural and educational post-secularist settings. Such developments find their parallels among other religious minority groups in the Near and Middle East (seen as "heterodox" by the majority "normative" tradition¹² and can be also accompanied by projects to "modernize" Alevi/Bektāşī theology.¹³

¹¹ On Twelver Shi'ite proselytizing and publishing programmes, initiated by the Islamic Republic of Iran) and focused on Alevism in Turkey, see: Bilici, "The Function of Alevi-Bektashi Theology," 55-57; Erman and Göker, "Alevi Politics in Contemporary Turkey," 105-106; for some of their more radical offshoots, see Ruşen Çakır, *Ayet ve Slogan Türkiye'de İslami Oluşumla*, İstanbul: Metis, 1990, 155-164.

¹² For analogous recent developments among the Ahl-e Haqq, see: Ziba Mir-Hosseini, "Breaking the Seal: The New Face of the Ahl-i Haqq", in *Syncretistic Religious Communities*, eds. Kehl-Bodrogi, Kellner-Heinkele and Otter-Beaujean, 175-195.

¹³ On this process, see: Çamuroglu, "Alevi Revivalism ", 82-83; *idem*, "Some Notes", 30-31; Bilici, "The Function of Alevi-Bektāşī Theology in Modern Turkey", 57-59; Tord Olsson, "Epilogue: The Scripturalization of Ali-Oriented Religions", in *Alevi Identity*, eds. Olsson, Özdalga and Raudvere, 199-209; Anke Otter-Beaujean, "Schriftliche Überlieferung versus mündliche Tradition - zum Stellenwert der Buyruk-Handschriften im Alevitum", in eds. Kehl-Bodrogi, Kellner-Heinkele and Otter-Beaujean *Syncretistic Religious Communities*, 224-226 Şehriban Şahin, "The Rise of Alevism as a Public Religion," *Current Sociology*, 53:3 (2005), 465-485, David Shankland, "The *Buyruk* in Alevi village life: Thoughts from the field on rival sources of religious inspiration," in *Syncretismes et hérésies dans l'Orient seldjoukide et ottoman (XIVe- XVIIIe siècle)*. *Actes du Colloque du Collège de France, octobre 2001*, ed. Gilles Veinstein, Paris & Dudley, 2005, 311-324; Massicard, *L'Autre Turquie*, 150-160; Markus Dressler, "Religio-Secular Metamorphoses: The Re-Making of Turkish Alevism", *Journal of the American Academy of Religion*, 76:2 (2008), 286-288, 304-305.

As these developments are acquiring a renewed socio-religious dynamic in contemporary post-secular environments, they at least partially underlay and predicate the resurgence and reactivation of religious references and vocabulary in a series of current Alevi self-representational discourses and images, particularly in Turkey and the Balkans. In the educational sphere these shifts in religious and cultural self-awareness are reflected in the continuing disputes regarding the inclusion of Alevi-related topics into the mandatory religious courses in the Turkish state school system, as well as the successful campaign and policies leading to the integration of Alevi religious curricula in German and British public schools.¹⁴ Another important aspect of these religio-educational aspirations and processes concern the plans for the establishment of high schools and modern educational programmes for the Alevi *dedes*,¹⁵ clearly intended to bring higher theological learning to Alevi clerical leadership analogous to that needed for Sunni and Shi'ite religious scholarship. Among West European Alevi diasporas, moreover, such religio-educational agendas can be concurrent with maintaining a central focus on the synthesis of Sufi and humanistic ideals in Alevi religiosity (while occasionally deemphasizing its Islamic theological and historical contexts) to build up an image of Alevism along the fashionable modern model of a world religious philosophy which treasures universal spiritual traits and has a trans-religious appeal.¹⁶

The Alevi and Bektāşī communities in the Balkans endured the similar processes of migration, immigration, urbanization and secularization brought by the onset of post-Ottoman modernity and more recently, post-secular religiopolitical transmutations.

¹⁴ On the pioneering introduction of Alevi lessons as part of the compulsory Religious Education curriculum in British schools, see: Celia Jenkins & Umit Cetin, "From a 'Sort of Muslim' to 'Proud to be Alevi': the Alevi Religion and Identity Project Combatting the Negative Identity among Second-generation Alevi in the UK", *National Identities*, 2017, DOI: 10.1080/14608944.2016.1244933

¹⁵ On these initiatives, see: Şahin, "The Rise of Alevism as a Public Religion", 476 ff.; Dressler, "The Modern Dede", 276-287; *idem*, "Religio-Secular Metamorphoses", 299-304; Martin Sökefeld, *Struggling for Recognition: The Alevi Movement in Germany and in Transnational Space* (Oxford: Berghahn Books, 2008), 147-178, *passim*.

¹⁶ On these attempts, see: Dressler, "Religio-Secular Metamorphoses," 292-293, 304-305; Vorhoff, "Discourses on the Alevi", 101.

However, the course and outcomes of these analogous processes in the post-Ottoman Balkans and Turkey were impacted by dissimilar socio-political and ideological factors. In the Balkans these ideological factors incorporated the crucial question of the origins and ethnic composition of the modern Slavophone Muslim groups in South-Eastern Europe: Bosnia, Bulgaria, Serbia, Northern Macedonia, Montenegro and Greece. That question was one of the principal concerns of Balkan nationalist historiographies and nation-building ideologies in the late Ottoman and early post-Ottoman periods. The creation of ideological models dealing with the vital ethno-confessional and religiopolitical dimensions of this problem took place in a period when Alevism and Bektāšism entered popular and elite discourses focused on the wider area of Ottoman-era Christian-Islamic inter-relations. Some of these models re-imagined the ethno-genesis and confessional orientation of the Slavophone Muslim, Alevi and Bektāšī Balkan groups in sweepingly reconstructed historical contexts of Islamicisation and Turkification processes in the Ottoman empire.

The provenance, original settlements and peregrinations of the *Kızılbaş* communities and the Bektāšī order in the Balkans certainly is one of the most complex religio-historical problems arising from the Ottoman empire's early religious and political history. Early and recent research on the Islamic heterodox groups in the central and eastern Balkans (who variously self-identify as being of Baba'i, Bektāšī or *Kızılbaş* ancestry) has accumulated enough evidence that some of these groups certainly derive from pro-Safavid *Kızılbaş* deportees forcibly re-settled by the Ottoman authorities in the sixteenth century-Balkans. Other groups may descend from heterodox Turkoman groups, who, led by dervishes and charismatic leaders, settled into the Balkans in the initial phases of the Ottoman expansion or even earlier periods.¹⁷ Regrettably, the investigation of the migrations, spread and religious geography of the *Kızılbaş* communities and the Bek-

¹⁷ See the recent discussions of the state of evidence and research in Frederick De Jong, "Problems concerning the Origins of the Qizilbāš in Bulgaria: Remnants of the Safaviyya?", in *Convegno sul tema: La Shi'a nell'Impero Ottomano (Roma, 15 Aprile 1991)* (Rome: Accademia nazionale dei Lincei, 1993), 203-16; Nevena Gramatikova, *Neortodokslanijat isliam v bŭlgarskite zemi. Minalo i suvremennost*, Sofia: Gutenberg, 2011

tāṣī order in the Balkans has been obstructed by the serious damage wreaked on many *Kızılbaş*/Alevi and Bektāṣī cultic sites in the course of the military conflicts leading to post-Ottoman Balkan states-formation.¹⁸ During this period of political and military conflicts in the region in the late nineteenth and early twentieth centuries, some of the traditional Alevi and Bektāṣī networks in the Balkans were disrupted and fragmented, while a number of their communities were displaced. Even before these turbulent decades the Bektāṣī order had already suffered massive and irretrievable losses because of its formal ban in 1826 and the ensuing confiscation of its religious edifices and property.

Early publications on Alevism and Bektāṣīsm in the Balkans and Anatolia drew on a rather limited access to relevant internal or external historical and doctrinal primary evidence. Such early Western accounts dating from late Ottoman period comprised the first-hand observations and experiences of Western diplomats, travelers, historians, anthropologists, travelers or missionaries, gathered at *Kızılbaş* and Bektāṣī cultic sites and complexes before many of them were gravely damaged or destroyed during subsequent conflicts. Such early reports also could record oral lore and ritual practices some of which since may have all but disappeared. At the same time, these reports need to be used cautiously and critically since they reflect several evident Orientalist, theological and missionary presumptions and attitudes.¹⁹

Within the cultures and scholarship post-Ottoman South-Eastern Europe and Kemalist Turkey the initial stances and

¹⁸ See, for example, the analysis of the damage and destruction inflicted on the Bektāṣī order in Albanian and Greek Epirus in Nathalie Clayer, *L'Albanie, pays des derviches: les ordres mystiques musulmans en Albanie à l'époque post-ottomane (1912-1967)*, Berlin: Harrassowitz, 1990, 181-185; Harry T. Norris, "Bektashi Life on the Border Between Albania and Greece", in David Shankland, ed., *Archaeology, Anthropology and Heritage in the Balkans and Anatolia*, ed. Shankland, 309-328; *idem*, "The Bektashiyya brotherhood, its village communities and inter-religious tensions along the border between Albania and Greek Epirus at the beginning of the 20th century", in *idem*, *Popular Sufism in Eastern Europe: Sufi Brotherhoods and the Dialogue with Christianity and "Heterodoxy"* (New York and London: Routledge, 2006), 78-92.

¹⁹ Karakaya-Stump, "The Emergence of the Kizilbas in Western Thought"; Kieser, "Muslim Heterodoxy and Protestant Utopia".

reports on Alevism and Bektāşism show inevitable indebtedness to the preoccupations and aims of the rival regional nation/ state-building programmes and designs. The emerging approaches to the belief system and history of Alevism and Bektāşism were shaped under the strong impact by the newly formulated grand interpretative schemas of Islamic-Christian interrelations in the Ottoman era, as formulated and elaborated in the contemporary Balkan national historiographies. These competing historiographies were particularly concerned with the Islamicisation processes in Ottoman-era Anatolia and Balkan Europe as well as the ethnic, cultural and linguistic provenance of the Balkan Slavophone Islamic communities and enclaves. One of the early interpretative models of these historiographies posited that the late medieval dissenting sectarian communities adhering to the Christian dualist heresies of Bogomilism and Paulicianism,²⁰ chose to embrace Islam *en masse* in the early phases of the establishment of Ottoman rule over the Balkans. This sweeping conversion scenario was rested on uncritical assumptions that late medieval Christian dualist communities made a conscious choice to convert as a whole to Islam in an ultimate response to earlier cycles of suppression and crackdowns to which they had been intermittently subjected by the policies of the secular and ecclesiastical authorities in medieval Byzantine and Balkan Orthodox Christendom.²¹

Exploited early to expound the advance of Islamicisation in early Ottoman Bosnia and Herzegovina (which witnessed an outbreak of conflict between Roman Catholicism and the schismatic Bosnian Church immediately before the Ottoman conquest)²², this

²⁰ On the origins, spread and doctrinal traditions of the Christian dualist movements and trends in the medieval Byzantine and Eastern Christian world, see the anthology of translated primary sources in Janet Hamilton and Bernard Hamilton, eds., Yuri Stoyanov, assist. ed., *Christian Dualist Heresies in the Byzantine World c. 650-c. 1450* (Manchester and New York), 1998.

²¹ For an analysis of the early formulations and main arguments of these theories as well as some of their more recent reinstatements, see Yuri Stoyanov, "On Some Parallels between Anatolian and Balkan Heterodox Islamic Traditions and the Problem of their Coexistence and Interaction in the Ottoman Period", in *Sycrétismes et hérésies*, ed. Veinstein, 83-90.

²² The Bosnian church had evolved as an ecclesiastical body, schismatic both from Catholicism and Eastern Orthodoxy; the exact nature and evo-

conversion model was subsequently broadened to be applied to the origins and history of most of the Balkan Slavophone Islamic communities. Such historiographic schemas thus reconstructed substantial groups of the modern-day Balkan Slavophone Muslim population (who predominantly adhere to Hannafi Sunni Islam) as heirs of medieval Christian heretics.²³ Subsequent evidence-based research and the growing availability of diverse primary source material conclusively exposed the untenability of such sweeping, ideologically-driven scenarios of large-scale Islamicisation among late medieval Balkan heterodox and dissenting groups. However, in the earlier stages of the formulation and dissemination of these theories, the Alevi and Bektāṣī communities were particularly liable to be drawn into such scenarios and narratives of assumed massive conversion of Christian heretical groups to Islam.

Early popular and scholarly interest in the potential Christian or Christian-influenced elements in the various layers of Alevi-Bektāṣī syncretism could be thus heavily ideologized and theologized and then incorporated into the emerging post-Ottoman ethno-confessional constructs, with all their actual geographical and religious territoriality ambitions. The policies implemented by the new political and religious establishments in the post-Ottoman Christian-majority successor states presented different strategies in dealing with the inherited multi-confessional polities in their territories, as discernible, for example, in the post-World War I kingdoms of Yugoslavia and Greece. During this period the earlier theories for assuming Christian origins of *Kızılbaşım* and Bektāṣīm were to a cer-

lution of its inter-relations with Christian dualist movements in the Western Balkans and Western Europe have attracted a prolonged and ongoing debate, especially in the last few decades - see Yuri Stoyanov, 'Between Heresiology and Political Theology: the Rise of the Paradigm of the Heretical Bosnian Church and the Paradoxes of its Medieval and Modern Developments', in *Political Theologies of the Monotheistic Religions. Representation of the Divine and Dynamics of Power* (Brescia: Morcelliana, 2005), ed. Giovanni Filoramo, 161-180.

²³ See, for example, Konstantin Ireček, *Istorija na bŭlgarite*, Tŭrnovo, 1886 (2nd ed., Sofia, 1929), 271, 289; Aleksandŭr Teodorov-Balan, "Bŭlgarskite katolitsi v Svishtovsko i tiahnata cherkovna borba", *Letopis na bŭlgarskoto knizhovno druzhestvo*, 2, 1902, 123ff.; more recently, Stavro Skendi, "Cryp-to-Christianity in the Balkan Area under the Ottomans", in Stavro Skendi, *Balkan Cultural Studies*, (Boulder, Colo. & New York, 1980) 240.

tain extent absorbed into the historical, religious and general discourses arising from the crystallization of nation-building historiographies

Despite its slow and uneven progress (particularly in the South East European Eastern Bloc states during the Cold War era), subsequent evidence-oriented research on Alevi and Bektāšī religious and cultic complexes in the Balkans (some of which have been reclaimed by the respective communities in the post-Communist period), anthropological fieldwork and close investigation of Ottoman-era sources have made a series of vital contributions to the relevant spheres of Ottoman political, religious and cultural history, Christian-Muslim and Sunni-Shi'ite inter-relations, particularly in the area of local studies.²⁴ The rich and diverse material assembled in these publications, their arguments and conclusions are especially significant for the further study of the role of the dervish orders (and Bektāšism, in particular) in the advance and nature of the Ottoman colonization of the Balkans, the rise, development and main patterns of Christian-Islamic syncretism, the phenomenon of crypto-Christianity and some other related spheres.²⁵ However, notwithstanding the extensive and increasing evidence to the contrary, the schemas and theories assuming a pre-Ottoman Slavonic Christian identity of the Balkan *Kızılbaş* and Bektāšī groups have persisted into the post-Communist period in ideology-driven and improvised historiographies of the Balkans in the Ottoman period.

Balkan Alevi and Bektāšī religious and cultural traditions endured for decades the militant secularist policies enforced in various intensity by the respective Eastern Bloc Communist regimes. The process of reclaiming religious and cultural Alevi and Bektāšī

²⁴ See the surveys of the development of the local studies of the Alevi and Bektāšī groups South-east Europe in Nevena Gramatikova, "Changing Fates and the Issue of Alevi Identity in Bulgaria," in *Ethnology of Sufi Orders: Theory and Practice: Proceedings of the British-Bulgarian Workshop on Sufi Orders 19-23 May 2000, Sofia, Bulgaria*, ed. Antonina Zhelyazkova and Jorgen Nielsen, (Sofia: IMIR: 2001), 567-581; Lybomir Mikov, *Kultova arhitektura i izkustvo na heterodoksnite miusulmani v Bŭlgaria (XVI-XX vek) bektashi kŭzŭlbashi/alevii* (Sofia; Al "Marin Drinov", 2005 (repr. 2007)), 21-33 *passim*.

²⁵ Analysis of the importance of this newly accumulated evidence of Alevism and Bektāšism for these fields in Yuri Stoyanov. "On Some Parallels",

identities in the Orthodox-majority cultures in South-Eastern Europe as well as in a variety of post-secular settings is still in its early stages. These communities are now exposed to local and transnationally coordinated Sunnification pressures and Twelver Twelver Shi'ite pro-active proselytizing and educational programmes, originating from the Islamic Republic of Iran. At the same time, the post-Communist South-East European cultures in general have continued to reimagine and reformulate their identities in the framework of a Slavo-Turkic heretical imaginary, conceptualized in the respective late-and post-Ottoman nation-building historiographies. Significantly, in some cases this process occurs in the framework of a post-secular instrumentalization of the so-called "pre-continuity" approach²⁶ (continuously utilized in the Balkans from the late nineteenth century onwards), in which an assumed pre-Ottoman Slavonic heretical past provides the religio-cultural framework for the re-legitimization and reassertion of the identity of modern-day Slavonic- and even Albanian-speaking Muslim communities in South-Eastern Europe.

²⁶ Nathalie Clayer, "The Issue of the Conversion to Islam in the Restructuring of Albanian Politics and Identities", *La perception de l'héritage ottoman dans les Balkans*, ed. Sylvie Ganglof, (Paris: L'Harmattan, 2005), 95-128 (discussing the case of Albanian Muslim identities – the specific dynamics of the evolution and political role of Bektāşism in late Ottoman and post-Ottoman Albania and its marked post-Communist revival remains outside the scope of this article, see the brief summary of this process in Yuri Stouyanov, "Contested Post-Ottoman Alevi and Bektashi Identities in the Balkans and their Shi'ite Component", ed. Lloyd Ridgeon, *Shi'i Islam and Identity: Religion, Politics and Change in the Global Muslim Community*, (London: Tauris, 2012), pp. 185-191.

Literature

- Bilici, Faruk. (1998). "The Function of Alevi-Bektashi Theology in Modern Turkey", in ., *Alevi Identity: Cultural, Religious and Social Perspectives*, ed. Tord Olsson, Elisabeth Özdalga and Catharina Raudver, (Istanbul: Swedish Research Institute, 51-63.
- Çakır, Ruşen. (1990). *Ayet ve Slogan Türkiye'de İslami Oluşumla*, (Istanbul: Metis).
- Çamuroglu, Reha. (1997). "Some Notes on the Contemporary Process of Restructuring Alevilik in Turkey," in *Syncretistic Religious Communities in the Near East*, ed. Krisztina Kehl-Bodrogi, Barbara Kellner-Heinkele and Anke Otter-Beaujean, (Leiden: Brill), 25-33.
- Çamuroglu, Reha- (1998). "Alevi Revivalism in Turkey", in *Alevi Identity: Cultural, Religious and Social Perspectives*, ed. Tord Olsson, Elisabeth Özdalga and Catharina Raudvere (Istanbul: Swedish Research Institute), 79-85.
- Clayer, Nathalie, *L'Albanie, pays des derviches: les ordres mystiques musulmans en Albanie à l'époque post-ottomane (1912-1967)*, (Berlin: Harrassowitz, 1990).
- Clayer, Nathalie. (2005). "The Issue of the Conversion to Islam in the Restructuring of Albanian Politics and Identities", *La perception de l'héritage ottoman dans les Balkans*, ed. Sylvie Ganglof, (Paris: L'Harmattan), 95-128.
- Dressler, Markus. (1999). *Die civil religion der Türkei. Kemalistische und alevitische Atatürk-Rezeption im Vergleich* (Würzburg: Ergon).
- Dressler, Markus. (2002). *Die alevitische Religion. Traditionslinien und Neubestimmungen* (Würzburg: Ergon).
- Dressler, Markus. (2006). "The Modern Dede: Changing Parameters for Religious Authority in Contemporary Turkish Alevism," in *Speaking for Islam: Religious Authorities in Muslim Societies*, ed. Gudrun Krämer and Sabine Schmidtke (Leiden: Brill), 269-294.
- Dressler, Markus. (2008). "Religio-Secular Metamorphoses: The Re-Making of Turkish Alevism", *Journal of the American Academy of Religion*, 76/2: 280-311.
- Erman, Tahire. and Emrah, Göker. (2000). "Alevi Politics in Contemporary Turkey," *Middle Eastern Studies*, 36/4: 99–118.
- Faroqhi, Suraija. (1981). *Der Bektaschi-Orden in Anatolien: (vom späten fünfzehnten Jahrhundert bis 1826)*, Vienna: Verlag des Institutes für Orientalistik der Universität Wien.
- Faroqhi, Suraija. (1995). "Conflict, Accommodation and Long-Term Survival. The Bektaşî Order and the Ottoman State (Sixteenth-seventeenth centuries)", in *Bektachiyya, Etudés sur l'ordre mystique des Bektachis et les groupes relevant de*

- Hadji Bektach, ed. Alexandre Popovic and Gilles Veinstein, (Paris: Geuthner), 167-181.
- Göner, Özlem. (2005). "The Transformation of the Alevi Collective Identity," *Cultural Dynamics*, 17:2: 107-134.
- Gramatikova, Nevena. (2001). "Changing Fates and the Issue of Alevi Identity in Bulgaria," in *Ethnology of Sufi Orders: Theory and Practice: Proceedings of the British-Bulgarian Workshop on Sufi Orders 19-23 May 2000, Sofia, Bulgaria*, ed. Antonina Zhelyazkova and Jorgen Nielsen, (Sofia: IMIR), 564-622.
- Gramatikova, Nevena. (2011). *Neortodokslianiat isliam v bŭlgarskite zemi. Minalo i suvremennost*, (Sofia: Gutenberg).
- Hamilton, Janet and Bernard, Hamilton. (1998). eds., Yuri Stoyanov, assist. ed., *Christian Dualist Heresies in the Byzantine World c.650-c.1450* (Manchester and New York).
- Irećek, Konstantin. (1929). *Istoriia na bŭlgarite*, Tŭrnovo, 1886 (2nd ed., Sofia).
- Ivanov, Vladimir. (1950). *The Truth-Worshippers of Kurdistan: Ahl-i haqq Texts*, Bombay: Matba'-'i Qādirī.
- Jenkins, Celia and Umit, Cetin. (2017). "From a 'Sort of Muslim' to 'Proud to be Alevi': the Alevi Religion and Identity Project Combatting the Negative Identity among Second-generation Alevis in the UK", *National Identities*, DOI: 10.1080/14608944.2016.1244933.
- Jong, Frederick De. (1993). "Problems concerning the Origins of the Qizilbāş in Bulgaria: Remnants of the Safaviyya?", in *Convegno sul tema: La Shi'a nell'Impero Ottomano (Roma, 15 Aprile 1991)* (Rome: Accademia nazionale dei Lincei), 203-16.
- Karakaya-Stump, Ayfer. (2004). "The Emergence of the Kizilbas in Western Thought: Missionary Accounts and their Aftermath", in *Archaeology, Anthropology and Heritage in the Balkans and Anatolia: the Life and Times of F.W. Hasluck, 1878-1920*, ed. David Shankland, (Istanbul: Isis), vol. 1, 328-353.
- Karamustafa, Ahmet T. (1993). "Çalenders, Abdâls, Hayerîs: The Formation of the Bektâşîye in the Sixteenth Century", in *Süleyman the Second and his Time*, ed. Halil Inalcik and Cemal Kafadar (Istanbul: Isis), 121-129.
- Karamustafa, Ahmet T. (2005). "Origins of Anatolian Sufism", in *Sufism and Sufis in Ottoman Society: Sources, Doctrine, Rituals, Turuq, Architecture, Literature and Fine Arts, Modernisms*, ed. Ahmet Y. Ocak (Ankara: Türk Tarih Kurumu), 67-95.
- Kieser, Hans-Lukas. (2001). "Muslim Heterodoxy and Protestant Utopia. The Interactions between Alevis and Missionaries", *Die Welt des Islams*, n. s., 41:1: 89-111.

- Massicard, Élise. (2005). *L'Autre Turquie. Le mouvement aléviste et ses territoires* (Paris: PUF Proche Orient).
- Mélikoff, Irène. (2001). *Au banquet des quarante: exploration au coeur du bektachisme-alevisme*, Istanbul: Isis.
- Mélikoff, Irène. (1992). *Sur les traces du soufisme turc: recherches sur l'Islam populaire en Anatolie*, Istanbul: Isis.
- Mélikoff, Irène. (1998). *Hadji Bektach: un mythe et ses avatars: genèse et évolution du soufisme populaire en Turquie*, Leiden: Brill.
- Mikov, Lybomir. (2005). *Kultovna arhitektura i izkustvo na heterodoksnite miusulmani v Bŭlgaria (XVI-XX vek)bektashi kŭzŭlbashi/alevii* (Sofia; AI "Marin Drinov", (repr. 2007).
- Mir-Hosseini, Ziba. "Breaking the Seal: the New Face of the Ahl-i Haqq", in *Syncretistic Religious Communities*, ed. Kehl-Bodrogi, Kellner-Heinkele and Otter-Beaujean, 175-195.
- Norris, Harry T. "Bektashi Life on the Border Between Albania and Greece", in David Shankland, ed., *Archaeology, Anthropology and Heritage in the Balkans and Anatolia*, ed. Shankland, 309-328.
- Norris, Harry T. (2006). "The Bektashiyya brotherhood, its village communities and inter-religious tensions along the border between Albania and Greek Epirus at the beginning of the 20th century", in Harry T. Norris, *Popular Sufism in Eastern Europe: Sufi Brotherhoods and the Dialogue with Christianity and "Heterodoxy"* (New York and London: Routledge), 78-92.
- Olsson, Tord. "Epilogue: The Scripturalization of Ali-Oriented Religions", in *Alevi Identity*, ed. Olsson, Özdalga and Raudvere, 199-209.
- Otter-Beaujean, Anke. "Schriftliche Überlieferung versus mündliche Tradition - zum Stellenwert der Buyruk-Handschriften im Alevitum", in ed. Kehl-Bodrogi, Kellner-Heinkele and Otter-Beaujean *Syncretistic Religious Communities*, 224-226.
- Otter-Beaujean, Anke. "Schriftliche Überlieferung versus mündliche Tradition - zum Stellenwert der Buyruk-Handschriften im Alevitum", in *Syncretistic Religious Communities*, ed. Kehl-Bodrogi, Kellner-Heinkele and Otter-Beaujean, 212-226.
- Şahin, Şehriban. (2005). "The Rise of Alevism as a Public Religion," *Current Sociology*, 53:3 (2005), 465-485.
- Shankland, David. (2005) "The Buyruk in Alevi village life: Thoughts from the field on rival sources of religious inspiration," in *Syncretismes et hérésies dans l'Orient seldjoukide et ottoman (XIVe- XVIIIe siècle)*. Actes du Colloque du Collège de France, octobre 2001, ed. Gilles Veinstein, Paris & Dudley, 311-324.

- Skendi, Stavro. (1980). "Crypto-Christianity in the Balkan Area under the Ottomans" in Stavro Skendi, *Balkan Cultural Studies* (Boulder, Colo. & New York), 233-257.
- Sökefeld, Martin. (2002). "Alevi Dede in the German Diaspora: The Transformation of a Religious Institution," *Zeitschrift für Ethnologie* 127: 163-186.
- Sökefeld, Martin. (2008). *Struggling for Recognition: The Alevi Movement in Germany and in Transnational Space* (Oxford: Berghahn Books).
- Stoyanov, Yuri. "On Some Parallels between Anatolian and Balkan Heterodox Islamic Traditions and the Problem of their Coexistence and Interaction in the Ottoman Period", in *Sycretismes et hérésies*, ed. Veinstein, 75-119.
- Stoyanov, Yuri. (2005). "Between Heresiology and Political Theology: the Rise of the Paradigm of the Heretical Bosnian Church and the Paradoxes of its Medieval and Modern Developments", in *Political Theologies of the Monotheistic Religions. Representation of the Divine and Dynamics of Power* (Brescia: Morcelliana), ed. Giovanni Filoramo, 161-180.
- Teodorov-Balan, Aleksandŭr (1902). "Bŭlgarskite katolitsi v Svishtovsko i tiahnata cherkovna borba", *Letopis na bŭlgarskoto knizhovno druzhestvo*, 2: 101-211.
- Vorhoff, Karin. (1995). *Zwischen Glaube, Nation und neuer Gemeinschaft. alevitische Identität in der Türkei der Gegenwart* (Berlin: K. Schwarz Verlag).
- Vorhoff, Karin. (1997). "Discourses on the Alevis in Contemporary Turkey", in *Syncretistic Religious Communities in the Near East*, ed. Krisztina Kehl-Bodrogi, Barbara Kellner-Heinkele and Anke Otter-Beaujean, (Leiden: Brill), 94-110.
- Vorhoff, Karin. (1998). "Let's reclaim our history and culture!"—Imagining Alevi community in contemporary Turkey", *Welt des Islams*, 38: 220-252.
- Yaman, Ali. (2006). *Kızılbaş Alevi Ocakları* (Ankara, Elips).

VLADISLAV YERYOMIN

Department of Philosophy,
Cultural Studies and Information Services Faculty of Law,
Volodymyr Dahl East Ukrainian National University, Ukraine,
Lugansk region, Severodonetsk

Concepts of the Unity of Religions in the Teachings of New Age and the Traditionalism of R. Guénon

Abstract

The aim of the work is to carry out a comparative analysis of the idea of the unity of religions in the teachings of New Age and the traditionalism of R. Guénon in the context of Cultural Studies. The methodology of the research is to combine comparative, logical and historical methods. Scientific novelty. In the post-Soviet space the research of the phenomenon of "New Age" has been conducted since the mid-1990s. Among its researchers D. Manchenko, A. Shchedrin, Yu. Kosorukova can be called. The topic of integral traditionalism is less explored. In domestic science A. Shchedrin, S. Vyshynskiy, O. Gutsulyak are involved in it, but this comparative analysis was not the subject of a separate review. Conclusions. The concepts of the unity of religions in the "New Age" teachings and integral traditionalism have both common and different sides. The first of them demonstrate eclecticism of religious teachings, both among themselves and with ideas of Modernity and Postmodern; R. Guénon seeks to discover esoteric unity of religions, avoiding eclecticism and abstracting as much as possible from the latter.

Keywords: New Age, integral traditionalism, unity of religions, orthodoxy, esotericism, initiatory chain, individualism.

Introduction

■ The religious palette of the modern world, especially the western one, is distinguished by an unprecedented variety of teachings and cults that has become an integral part of the culture of post-industrial society. In this regard, attempts to comprehend this diversity at a deep philosophical level do not stop. Among the concepts of this kind, an important place is occupied by the idea of internal

(and higher) unity of religions, which has a long history and various forms of expression in modern culture.

The purpose of the work is to carry out a comparative analysis of the idea of the unity of religions in the New Age teachings and the traditionalism of R. Guénon in the context of Cultural Studies. The choice of the topic is due, firstly, to the lack of direct research in this context, and secondly, to the fact that the issue of demarcation between traditional and new religious movements in contemporary culture is open and controversial.

In the post-Soviet space, the study of the phenomenon of “New Age” has been conducted since the mid-1990s. Among its researchers D. Manchenko, A. Shchedrin, Yu. Kosorukova can be called. The topic of integral traditionalism is less studied; A. Shchedrin, S. Vyshynskiy, O. Gutsulyak deal with it in Ukrainian science, however, a comparative analysis of views on the unity of religions in these teachings was not the subject of separate consideration.

Perennialism

Before starting to consider the idea of the internal unity of religions, it is necessary to determine its place in the history of religious and philosophical teachings. Most modern scholars of religion consider this idea generally alien to traditional confessions. S. Zharinov writes about this in his article, showing on different examples that the normal and natural state of religions is mutual negation (Zharinov, 2016). Italian historians of philosophy D. Antisery and G. Reale note that this idea has origins in the religious and philosophical thought of Antiquity – Pythagoreanism, Platonism and Hermeticism. This topic was investigated by the author of this article in another paper (Yeryomin, 2017-1: 83-88). The idea of the internal unity of religions takes the conceptual form only in Renaissance Neoplatonism.

The greatest interest in this respect is the Platonic Academy in Florence, founded in 1462 by the Italian philosopher Marsilio Ficino (1433-1499), who later took priesthood. Considering the Ficino’s theory of “illumination”, D. Antisery and G. Reale write: “The meaning of philosophical activity is to prepare the soul in such a way that the intellect is able to perceive the light of divine revela-

tion, <...>. Hermes Trismegistus, Orpheus, Zoroaster were equally “enlightened” by this light, therefore they are prophets, and their mission is to preserve the sacred, unrevealed truths. The fact that these “ancient theologians” could touch the same truth (which Pythagoras and Plato then received), according to Ficino, finds an explanation in the Logos, which is one for all. Christ embodied the Word, and that means the fullness of Revelation. Therefore, the works of Hermes, Orpheus, Zoroaster, Pythagoras, Plato (and Platonists) are easily consistent with the Christian doctrine, because both derive from the same source (the Divine Logos)” (Antisery, Reale, 2002: 45-46). According to the British historian M. Sedgwick, it was the Platonic Academy of Ficino that became the forge of *perennialism* – the notion of *Philosophia perennis* (“Eternal Philosophy”) as a common source and the secret (esoteric) content of various religions. The very term *Philosophia perennis* was introduced in 1540 by the Vatican librarian Agostino Steuko to determine M. Ficino’s main insight (Sedgwick, 2014: 39-40).

To understand the nature of this phenomenon, one should note a special character of the Renaissance itself. The well-known Russian philosopher A. Dugin writes that the formation of secular culture of this period allowed European intellectuals to look “from the outside” not just at Christianity, which was quite natural for Jewish and Muslim thinkers, but for the entire “bewitched world” of religious cultures. It was this distance (which did not always imply a complete break) that made it possible to define the latter as a “traditional society” or the paradigm of Premodern, singling out the common that united them. Further A. Dugin notes that one part of the thinkers of the Renaissance and early Modernity (G. Galilei, B. Telesio, F. Bacon) saw this “common” in *ignorance*, which should be eliminated by the development of experimental science and rational philosophy. This was the beginning of the “Enlightenment” project, which became the leitmotif of the epoch of Modern times. The other part of these thinkers (M. Ficino, P. della Mirandola, N. of Cusa) saw this “common” in *wisdom* (Sophia), the search and understanding of which marked the beginning of perennialism noted above (Dugin, 2009: 590-592). This dual nature of the Renaissance logically followed from the dual nature of Antiquity, to the heritage of which humanists and natural philosophers of the 15-16th centuries addressed themselves. This na-

ture was well illustrated by K. Marx, who distinguished in the antique philosophy “the line of Plato” and “the line of Democritus”, proudly considering himself the continuer of the latter. In the language of traditionalism, these two lines (and the corresponding tendencies in culture) can be called “sacred” and “profane” thinking. But if in Antiquity “Plato” as a whole eclipsed “Democritus”, displacing its successors to the sidelines of intellectual life, in the Renaissance – after the restoration of antique proportions – the situation began to reverse. The history of philosophy and science of Modern times only confirmed this vector of development of thought. However, strangely enough, these changes were in full agreement with Platonic historiosophy, according to which the world during the cycle of its existence is steadily moving toward its “materialization” (from the “golden” age to the “iron” one). Later this model of history will be perceived and rethought by R. Guénon and his school.

In the following centuries, perennialism existed on the periphery of European culture in the circles of Rosicrucians, Freemasons and Kabbalists (H. C. von Nettesheim, John Dee, H. Kunrath, R. Fludd), united today by the common term “Western esotericism”. But in the 19th century, it is experiencing a new upsurge and acquiring a new form. First of all, this was due to the discovery of the Vedas by Europe, which were taken for the oldest expression of *Philosophia perennis* (Sedgwick, 2014: 40). It is this form of perennialism, developed by a number of writers and mystics (Fabre d’Olivet, Saint-Yves d’Alveydre, Louis Jacolliot) formed the basis of the theosophy of H. Blavatsky, which became the ideological source of the New Age movement. It, a little later, was also received by R. Guénon, the founder of the school of integral traditionalism. However, in spite of this common source, the further development of these teachings went very different ways.

New Age

Now, after a short history of the subject of this study, it is necessary to proceed to its immediate consideration. Synthesizing different wordings, it is possible to define “New Age” as a collection of new non-traditional doctrines of a religious-mystical nature, initial-

ly united by the belief in the imminent coming of the “Age of Aquarius”. As a cultural phenomenon of the 20th century, New Age has a direct source in the theosophy of H. Blavatsky, spiritism and occultism of the 19th century. Having filled the “spiritual vacuum” of the late Modern times, it received rapid development in all of its cultural space. Almost all researchers of this phenomenon note that the idea of the “esoteric unity of religions” (from the Greek ἑσωτερικός – “inner”, “hidden”) is its main feature. In the New Age literature one can find a reference to the “spiritual center of the Earth” (Asgartha of H. Blavatsky, Shambhala of H. and N. Roerich), which stores the same for all religions esoteric knowledge (Kliman, 2013).

The original basis of the New Age worldview is the astrological concept that the era of Aquarius, characterized by the synthesis of various creeds and achievements of secular science, should replace the era of Pisces (associated with Christianity). The change of astrological eras is connected with the displacement of the point of vernal equinox, which falls on March 20 or 21, from one zodiacal constellation to another against the course of the zodiacal circle. This is made possible by such a phenomenon as precession. Precession means that the axis, around which the Earth rotates, under the influence of the attraction of the Moon and the Sun deviates slightly, describing the cone in space. Thus, over time, for the Earth observer, the Sun begins to project into other zodiacal constellations. The last 2000 years it met the vernal equinox in the constellation of Pisces, and before that – in the constellations of Aries, Taurus, Gemini, etc. In the 20-21th centuries, according to this concept, the point of the vernal equinox passes into the constellation of Aquarius, which entails deep cultural changes for all mankind. However, the zodiac *constellations*, in contrast to the *signs* of the Zodiac, do not have clear boundaries. For this reason, there is no specific date, which could be considered the end of one and the beginning of another era. Astrological eras last an average of about two thousand years, so they are not replaced one by one, but gradually.

Later, many teachings, not related to the concept of the “Age of Aquarius” (e.g., neopaganism, various psychotherapeutic and health systems), were included in the New Age phenomenon. However, it is this concept, open to arbitrary interpretations, served as the core around which this phenomenon was originally

formed. The very term “New Age” was proposed by Alice Bailey (1880-1949) – an English writer and an active figure in the Theosophical Society. She combined the theosophy of H. Blavatsky and her re-thought of perennialism with astrology and the concept of the “Age of Aquarius”. Such a course of thought made it possible to connect the doctrine of *Philosophia perennis* (in its latest edition) with the *idea of historical progress*, alien to both traditional religions and the very perennialism. This idea, which has a completely modern and secular origin, was rethought in the context of spiritualism. This traces the most important feature of the New Age teachings – the desire to combine science and religion by projecting the ideas of evolution and progress onto the sphere of spirit. This is how the central concept of these teachings emerged – the “spiritual evolution of mankind”.

The main conclusion that followed from this reasoning was that if earlier mankind was not ready to accept a single esoteric doctrine that was presented “under the cover” of traditional religions, then on the eve of the “Age of Aquarius” it was quite ripe for this. Channels of this disclosure, as S. Kliman notes, are “new revelations” that occur through the medium’s communication with the beings of the “subtle world”. An important role in the design of new doctrines is often played by the free fantasy of their creators. Such, in his opinion, is the nature of Theosophy, Agni Yoga, Anthroposophy, Rose of the World, Urantia Book, Scientology, Neo-Paganism, Channeling and other directions of the “New Age” (Kliman, 2013).

From this another important feature of the New Age teachings follows – *the desire for an external union of religions (after their “correction”) into a single whole* on the grounds that they have already played their role in the “evolution of mankind” or were hopelessly distorted (Blavatsky, 2005: 45). An alternative to such unification (in case of its failure) is the simple replacement of old religions by the “New One World Teaching”. About this the follower of Agni-Yoga A. Klizovsky writes: “The Brotherhood does not engage in the alteration of old caftans – by correcting distorted Teachings, but gives humanity a beautiful new apparel – the New Teaching. For every unprejudiced person, it must be clear that this is the only means to facilitate the way out of the old rut, that only the New

One World Teaching can unite the disunited nations and end the eternal and senseless disputes about the superiority of their gods and their beliefs” (Klizovsky, 2002: 82).

With all this, it is important to note the sympathy of the new-agers for the founders of traditional religions (whose “true” doctrine they revive) and the rejection of such phenomena as orthodoxy and dogmatics (especially when it comes to Christianity) that most of all hinder this “unification”. In this way of thinking the spirit of Postmodernism with its criticism of “logocentrism” and propaganda of unlimited freedom is easily recognized (Kliman, 2013; Manchenko, 2002). This is indicated by the close connection of New Age teachings with contemporary art (painting and music), with its rejection of canons, the increased importance of improvisation and “creative inspiration”. These features make it possible to identify with confidence New Age as *the religion of Postmodern*.

But, as noted by modern researchers, it is individualism, freedom of thought and creativity, inherent in the ideologists of New Age, that leave the project of universal religion as an empty declaration. This state of affairs blocks any attempt at centralization and unification of New Age teachings, which remain an extremely plural and scattered phenomenon of contemporary religious culture (Kosorukova, Bednenko, 2011). A similar situation occurred in the case of Protestantism, when the famous slogan *Sola Scriptura*¹ spawned a huge number of directions, churches and sects, the number of which continues to grow today (Guenon, 2008: 72).

In this regard, it is interesting to note the definition of New Age as a “meccano religion”, which is given to it by Yu. Kosorukova and G. Bednenko. In their article they show that for the ideologists of “new religions” the teachings of traditional religions are nothing more than “material” from which it is possible to arbitrarily “assemble” the most diverse constructions, following the instructions of

¹ The Protestant slogan *Sola Scriptura* (Latin “only Scripture”) associated with the idea of “the priesthood of all believers” in the 16th century was directed against the monopoly of the Catholic Church on the interpretation of the Bible. Ideologists of the New Age movement in fact extend this principle to all traditional religions, because in the “Age of Aquarius” every person becomes capable of direct communication with the “spiritual world”.

the otherworldly forces (Mahatmas, Ascended Masters, ancient pagan gods), personal taste or consumer demand (Kosorukova, Bednenko, 2011). The main condition for such a “freedom of creativity” is, again, the denial of the orthodox forms of these religions, responsible for the legitimate interpretation of their sacred texts. However, as D. Manchenko notes, this freedom does not concern the ordinary adherents of New Age, for whom, on the contrary, collectivism, dogmatism and strict submission to “spiritual teachers” are often typical (Manchenko, 2002). So, in a strange irony, the individualistic uprising against the dividing and dogmatic traditions (in the name of their single spiritual essence) has turned into even more dogmatism and division.

Traditionalism

A different view of the idea of the unity of religions belongs to the French thinker René Guénon (1886-1951), the founder of the school of integral traditionalism. The main feature of this school is that all the knowledge about the particular areas of the manifested world – nature, culture, science, art, politics, etc. – *is derived from the fundamental metaphysics*, the reconstruction of which is made through intuitive penetration into the secret meaning of Sacred scriptures. This common metaphysics, they believe, is most fully manifested in the East in the doctrine of Advaita Vedanta, and in the West – in the teachings of Plato and Neo-Platonists. In accordance with it, it is the spirit (the World of Ideas of Plato) that is understood as Being and Knowledge, whereas matter (χώρα of the ancient Greeks or *materia prima* of scholastics) is related to the concepts of Non-Being (μη ὄν) and Ignorance; the physical cosmos itself is the fruit of the union of these principles.

About two forces acting in the world during the cycle of its development R. Guénon writes: “... in fact, it is necessary to trace in all two opposite tendencies: one – descending, the other – ascending, or in other words, one – centrifugal, another – centripetal. On the predominance of a particular trend two complementary phases of manifestation depend: the first one – separation from the Principle, the second one – return to the Principle. These two

phases can be compared to beating of the heart or breathing (exhale and inhale), and although these two stages are most often regarded as consecutive, the two corresponding tendencies of manifestation should be regarded as simultaneous and only acting with varying degrees of intensity” (Guénon, 2008: 15-16). Here it is worth noting that traditionalists understand the “world” of the current cycle (Skt. Manvantara) not as the “universe” of secular science with its boundless expanses, but only the planet Earth in its current state (Skt. Jambu-Dvipa).

The manifestation of the force of universal attraction is Primordial Tradition – “pure metaphysical knowledge”, which was available to all mankind in the era of “Golden Age” (Skt. Satya-Yuga). The original place of its manifestation, according to traditionalists, was Hyperborea, an ancient continent that, according to legends, occupied the region of the North Pole (Guénon, 2008: 31). Always existing in the “spiritual center of the Earth” (Agartha), this Tradition operates in history through secondary “traditional forms” (religions and spiritual teachings). According to R. Guénon, in general they can be represented as branches of one tree or one river. Each such form, being an adaptation of the single knowledge to the specific conditions of place and time, generates a unique and distinct culture – the further application of a particular doctrine (e.g., Christian creed) to different areas of human life. The theme of the relationship between tradition and culture in the discourse of integral traditionalism was considered by the author of this work in a separate study (Yeryomin, 2017-2: 157-165).

Unlike the ideologists of the New Age, the French thinker rejects the idea of historical progress, affirming the regressive-cyclic conception of history. The real connection with the “supreme center”, in his opinion, is only in orthodox traditions (Guénon, 2008: 192-197). The basis and core of orthodoxy (from the Greek *ὀρθοδοξία* – “direct teaching”), according to R. Guénon, is formed by an *initiatory chain* through which there is a transfer of “spiritual influence” from the founder of the traditional form, having divine inspiration, to his modern successors (Guenon, 2008: 182-187). In his works the thinker distinguishes different types and levels of initiation. In the Indian culture, which he considered an example

of the traditional way of life, the initiatory chain or *guru parampara* occupies a special position. The well-known Ukrainian religious scholar I. Kozlovsky writes about this: “The most important condition for the existence of a religious tradition is a mechanism that ensures its preservation. Such can be the community, family customs, the system of upbringing and education, but the main, fundamental mechanism for transmitting the Vaishnava tradition is the spiritual continuity (*guru-paramparā*) (“from one mentor to another”). Every successor in such continuity is a pupil of the previous; so, through the teacher-student connection, knowledge and forms of religious experience are transmitted. Only a person who has gained control over himself can be considered the “link” of a parampara, which is a necessary condition for his moral and spiritual perfection – this protects the tradition from distortion. <...> Being a development of the tradition in time, the *guru-parampara* ensures its immutability and expresses its diachronic aspect” (Kozlovsky, 2013: 283).

Similarly, in the Tibetan culture, the initiatory chains (Tibetan *gyud-pa*) are “power lines” around which four schools of Vajrayana Buddhism (Nyingma, Kagyu, Sakya and Gelug) and the tradition of Yungdrung Bön (“bön of swastika”) were formed. These lines connect modern teachers and adherents of Tibetan Buddhism and Bön with the teachers of antiquity – Buddha Shakyamuni, Shenrab Miwo, Mahasiddhas of India and Uddiyana. As for European culture, the most graphic example of such a chain is the priestly ordination in Christianity (Guenon, 2008: 185).

It should be noted that R. Guénon himself in 1912 accepted Islam and initiation into the Shadhili tariqa, founded by Sufi Sheikh Abu al-Hasan ash-Shadhili in the 13th century. His example was followed by a number of his students – F. Schuon, M. Valsan, T. Burkhardt and K. Mutti. With all this, neither R. Guénon nor other traditionalists give absolute criteria for determining the “sacred legitimacy” of a particular tradition, since the origins of many initiatory lines (for example, Freemasonry) are necessarily shrouded in a veil of secrecy. This veil, opaque to skeptical reason, is removed only on the path of spiritual practice. Therefore, for the seeker, in addition to this principle of orthodoxy, the criterion of truth re-

mains the known evangelical commandment, according to which “every tree is known by its fruits”.

From the foregoing it follows that in a strictly traditional society a person had almost no chance to receive recognition as a spiritual teacher unless he was associated with orthodoxy as a link in the chain of its keepers. Chances of this kind were significantly increased during the periods of crisis of the prevailing tradition. In the history of ancient India, such time was the “Shraman epoch” (VI-V centuries BC) – a period of “excitement of minds”, when a number of philosophical schools and religious movements of anti-Brahmanist character arose. Among them, materialism and skepticism, cognate to their ancient Greek counterparts, as well as various forms of mysticism, born in the course of free and chaotic “experiments”, like those practiced by the New Age adepts, took a prominent place. According to the traditionalists, this crisis (like all others like it) was overcome by adapting the “attraction force” of the Absolute (Logos) to new conditions. This was manifested, firstly, in the spread of Buddhism, which they considered a special “offshoot” of the Vedic tradition, and secondly, in the transformation of Brahmanism into proper Hinduism with the bringing to the forefront of new deities and new forms of spiritual practice. In the case of the Greco-Roman civilization, the crisis was deeper and lasted longer, and in order to overcome it, the establishment of a qualitatively new religion – Christianity – was required. In the visit of the baby Jesus by “kings-wizards” R. Guénon sees the act of transferring to him spiritual authority by representatives of the “supreme center”, who always, as far as conditions permit, try to correct the state of the world, restoring its connection with the Sacred area (Guénon, 2008: 739-740).

Modern society, according to the traditionalists, is the complete opposite of the world of Tradition. Spiritual individualism and anarchism inherent in the culture of Postmodern led to a situation where nothing is needed to establish a new direction of the existing religion (for example, another Protestant church) or a completely new religion, except the mind, charisma and eloquence of the founder himself. Complemented by knowledge of

psychology, these qualities have become the main attributes of “new” teachers and prophets.

As for the initiatory chains forming, as noted above, the inner core of any genuine tradition, their purity and continuity are also endangered during times of its crisis. The “rupture” of such a chain, or the arbitrary alteration of the rituals and teaching associated with it, leads to a partial or total loss by the tradition of its orthodoxy. It is along this path, according to R. Guénon, that Protestantism, which in a sense is the prototype and model of the New Age teachings, has gone. As for these teachings, which the thinker calls “neo-spiritualism”, they, in his opinion, are completely deprived of legitimate initiation, and, consequently, of a real connection with the “supreme center” (despite the claims of their founders) (Guénon, 2008: 192-197). Parodic and grotesque initiations, which they contain, allow us to see in them a postmodern imitation of traditional spirituality. The source of the “New Age” phenomenon, according to R. Guénon, is not the spiritual world, but only the “subtle” or “psychic”² world, the connection with which requires not a full-fledged initiation, but only extrasensory abilities – congenital or specially developed.

From this point of view, many spiritual teachers of the 20-21st centuries – neo-Hinduists (Osho Rajneesh, Sri Chinmoy, Sai Baba), neo-Buddhists (L. Rampa, Lee Hongzhi, S. Asahara), neo-Sufis (G. Gurdjieff, P. Uspensky, M. Norbekov), neo-Pagans (from G. Gardner to A. Trehlebov) – with all their differences, reveal one common feature – *the lack of an initiatory connection with the traditions on whose behalf they are speaking*³.

² In his cosmology, R. Guénon follows the common for different religions division of the world into 3 levels: spiritual, psychic (or subtle) and physical. These are the three worlds of Hinduism (svar, bhuvah, bhuh) and the three cosmic areas of Neo-Platonists (World of Ideas, World Soul, material world). In Christianity, they correspond to “spiritual Heaven”, “underheaven airspace” and “earthly world”. This division reflects the principle of the analogy of micro- and macrocosm, characteristic of most spiritual teachings. Orthodox traditions, according to Guénon, are designed to ensure the connection and subordination of these levels in the world and human being.

³ In this case, it is not a matter of primary initiation (such as the mystery of baptism in Christianity), that connects a person to a tradition, that these people could well have, but only of the initiation of a priestly one, giving a person the status of a teacher within a specific traditional form.

Metaphysics and Religion

According to R. Guénon, only metaphysics is absolute in nature, whereas religious teachings, which are its manifestation in various historical conditions, are always relative (due to the “relativity” of these conditions). It is worth noting that the concept of “metaphysics” in traditionalism does not quite coincide with the similar concept in philosophy. R. Guénon himself defines the subject area of metaphysics as “the kingdom of universal principles” (Guénon, 2010). In the first approximation, it coincides with the “World of Ideas” of Plato, that is, with the “spiritual world”, beyond the bodily as well as the psychic (subtle) dimension of the universe. Metaphysics itself is the knowledge of these principles, expressed in a rational and conceptual form. Unlike philosophical metaphysics, it is not a product of thinking of human individuals, but is only perceived (as illumination) by those of them who possess the necessary qualities for this. This method of cognition was described by M. Ficino in the theory of “illumination”, which was discussed at the beginning of this article. Religious doctrine is the “dressing” of this knowledge in sensual images taken from the bodily and psychic spheres. It is necessary for the delivery of this knowledge (with the inevitable concealment of some of its aspects) to different peoples in different epochs. A. Losev in his work “Primeval Essence” has well shown how the platonic concepts of “One” and “World of Ideas” in Christianity are personalized and appear in the images of God the Creator and the celestial hierarchy of angels (Losev, 1997: 101-126).

On the metaphysical unity of religions R. Guénon writes: “Traditional forms can be compared with paths leading to the same goal and yet different, it is clear that one cannot follow different paths simultaneously and that, having entered one of them, one must steadfastly adhere to it to the end; because going from one to another, in general, you risk slowing down the progress, if not getting lost at all. Only the one who has reached the end, thereby overcoming all the other paths, <...> for him the forms no longer bear the character of ways or means which he no longer needs; they exist only as expressions of a single Truth, which, according to the circumstances, are just as appropriate to use as it is appropriate to speak in different languages, to be understood by those to whom you refer” (Guénon, 2008: 178-179).

It is the conditions of place and time – the psyche of different peoples – that is the reason for the plurality of religions, their mutual contradiction and denial, which the thinker considers normal and necessary for the integrity of “traditional forms” and their effective action in history. Conversely, he considers unacceptable and destructive for any true orthodoxy the “mutual recognition” of religions as the first step towards their unification (Guénon, 2008: 178-181). F. Schuon, a pupil of R. Guénon, even criticized some Catholic theologians (from the generation after the Second Vatican Council) for their intention to recognize the divine inspiration of non-Christian religions – a truth that seemed to be central to traditionalism (Schuon, 2007: 26). From this it follows that for traditionalists the truth about the internal unity of religions, as well as the truth about the relativity of dogmatics, is esoteric, and therefore under normal conditions it should not be stated openly or officially accepted by representatives of religious elites (to avoid New Age blending).

It is interesting to note that an open statement of these truths led R. Guénon himself to a conflict with the conservative leadership of the Catholic Institute, in which he gave lectures on Religious Studies, after which he was forced to leave teaching (Sedgwick, 2014: 47-52). Apparently, this contradiction prompted a number of modern Russian traditionalists, rooted in Orthodoxy, to declaratively abandon the idea of an esoteric unity of religions.

Conclusions

Thus, the concepts of the unity of religions in the New Age teachings and integral traditionalism have both common and different sides. Their main similarity is in the recognition of a single esoteric knowledge that is stored in the “spiritual center of the Earth” and underlies different religions. Differences between them can be divided into the following items:

The idea of a way to connect with the Sacred area: the New Age teachings indicate an independent from every tradition communication of a person with the spiritual world (*individ-*

ual and direct connection). According to R. Guénon, such communication is possible only in the bosom of the orthodox tradition, to which initiation serves the “door” (*collective and mediated connection*).

The concept of the world history: progressive-cyclic in the case of New Age teachings and regressive-cyclic in integral traditionalism.

Attitude to the idea of uniting religions: the New Age teachings support this idea; R. Guénon insists on the need for strict distinction of religions with their peaceful coexistence and “consent” at the level of esoteric elites.

Attitude to religions themselves: the New Age teachings think of themselves as a full-value substitute for traditional religions, considering themselves their “essence”. Traditionalism sees itself only as an explanatory commentary on the history of religions and civilizations (R. Guénon, M. Eliade), or as a political program for the restoration of traditional order in the oecumene of Modernity (J. Evola, A. Dugin).

Attitude to Modernity: the New Age teachings, as a rule, are in solidarity with the paradigm of Modernity (wishing only to supplement and correct it), whose ideas are actively perceived. Integral traditionalism puts itself in direct opposition to it.

These observations allow us to draw two other conclusions. Firstly, in modern cultural approaches to the classification and typology of religions, it makes sense to divide traditional and new religious trends as those that have shown their beneficial influence on the culture, society, physical and mental health of a person, and those which still have to do it. In the basis of their delimitation it is necessary to put the principle of *initiatory connection* of one or another organization with the “maternal” religious tradition, indicated by R. Guénon.

Secondly, regardless of the attitude of this or that religious trend towards the idea of the internal unity of religions, it is important to develop a “culture of denial” in relations between them, free from the extremes of mutual enmity and unification. The culture of such denial – calm, peaceful, but firm, has existed for thousands of years in India between Hindus, Buddhists, Jains, Parsis and representatives of other faiths.

Literature

- Antiseriy, D. and Reale, G. (2002). *Western philosophy from the origins to our days*. Vol. 3. *From the Renaissance to Kant* / trans. and edited by S. A. Maltseva. St. Petersburg: Pnevma.
- Blavatsky, H. (2005). *The Key to Theosophy* / trans. from English by K. Zaitseva. Moscow: RIPOL classic.
- Guénon, R. (2008). *The Crisis of the Modern World. Notes on Initiation. The Reign of Quantity and the Signs of the Times. The King of the World* / trans. from French by N. Melentyeva, T. Fadeyeva, T. Lyubimova, Yu. Stefanov. Moscow: Eksmo.
- Guénon, R. (2010). *Essays on tradition and metaphysics*. <<http://www.klex.ru/aja>>.
- Dugin, A. (2009). *Postphilosophy. Three paradigms in the history of thought*. Moscow: The Eurasian Movement.
- Yeryomin, V. (2017). The phenomenon of antique philosophy in the theory of culture of integral traditionalism. *Herald of the National Academy of Managerial Staff of Culture and Arts*. Kyiv: Millennium, No. 4.
- Yeryomin, V. (2017). Tradition and culture in the discourse of integral traditionalism: the relation of concepts. *Culture of Ukraine: a collection of scientific works*. Kharkiv: Kharkiv State Academy of Culture, No. 58.
- Zharinov, S. (2016). Criticism of the universalism of René Guénon. <https://vidya613.wordpress.com/2016/05/17/критика-универсализма-рене-генона/>
- Klizovsky, A. (2002). *Basics of the New Age world view*. Moscow: FAIR PRESS.
- Kliman, S. (2013). New world view (or New Age) as a crisis of the culture of "post-Christian" society. *Totallogy-XXI. Post-nonclassical research*. <http://nbuv.gov.ua/UJRN/totallogy_2013_29_13>.
- Kozlovsky, I. (2013). Sampradaya as a phenomenon of Indian religious culture. *Tradition and traditionalism. Almanac (2012-2013)*. Donetsk: Donbass.
- Kosorukova, Yu. and Bednenko, G. (2011). Ideology and modern culture of "New Age" as a crisis of post-Christian civilization. <http://pryahi.indeep.ru/history/new_age.html>.
- Losev, A. (1997). *The name. Selected works, translations, conversations, studies, archival materials / comp. and the general edition A. Taho-Godi*. St. Petersburg: Aleteya.
- Manchenko, D. (2002). "New Age" religions in the context of postmodern culture. <<http://www.dissercat.com/content/religii-novogo-veka-v-kontekste-kultury-postmoderna>>.

- Sedgwick, M. (2014). *Against the Modern World: Traditionalism and the Secret Intellectual History of the Twentieth Century* / trans. from English by M. Marshak, A. Lazarev. Moscow: New literary review.
- Schuon, F. (2007). *Obviousness and Mystery* / trans. from English by A. Uzhdavinis.

**VLADIMIR BAKRAČ
PREDRAG ŽIVKOVIĆ**

University of Montenegro, Faculty of Philosophy

EMIL HILTON SAGGAU

University of Copenhagen, Section for Church History

Some Sociological Aspects of Religiosity

(Religiosity in Contemporary Societies Between Neo-liberalism and Globalization)

Abstract

Abstract: Religion, as a social phenomenon, has not always played a central role all societies throughout all times. The period after the Second World War is characterized as such a period. Here religion lost in many modernized societies much of its former social significance. This development was closely bound to the growing atheism and secularism. We argue in this article that religion has been eroded by a series of social transformation. Namely, the industrialization, urbanization, large scale wars, state's ideological pressure leading to a lack of religious infrastructure and education. Transformation that all could be encapsulated as a sort of modernization. Numerous sociologists of religion have until recently to some level glorified the end of religion in modernity. However, this seems to have been a premature conclusion. In the late eighties and the nineties, the social and cultural reality, as wells as the states support to religion, changed, among other reasons, because of new economic and political developments – e.g. in Eastern Europe. Whether by accident or not, in the period after the fall of communism, religion has become revitalized on the social stage.

The revitalization of religion trajects along the same line as globalization and neoliberalism. These two phenomena seem to have changed the foundations of identity, which in turn affects religion, because religion is often used to form the sense of identity and identification. This article takes a deeper look into, how neo-liberalism and globalization has affected religiosity in order to pin out the central determinants and their effect on religiosity.

Keywords: religion, religiosity, globalization, identity, neoliberalism, welfare state.

Introduction

■ At the end of the second decade of the twenty-first century, in the era of the (post) modern and globalized societies, the significance and influence of religion has not become weaker. This social reality seem to be in contrast to what some sociologist, such as Brian Wilson, have claimed. Wilson argued that the process of modernization, industrialization, institutionalization, urbanization, etc. have eroded the foundation religiosity and lead to an increased secularization (Wilson, 1976). Wilson noted this change as a significance of modernity. Peter Berger went even further, and glorified the idea that religion is losing its influence on societal and individual level (Berger, 1973). Wilson and Berger and many others theory was a consequence of the rapid changes of Western societies in the post-war period. As Martikainen puts it “secularization theory is a theory of modernity, or rather modernization, which focuses on the destiny of religion” (Martikainen et al, 2012. p. 10).

However, these secularization theses of Berger and Wilson has been proved wrong in times of the perhaps most dramatic technical-technological revolutions, which were believed to be the vehicle of secularization. The opposite has happened – and today we see a religious revitalization, as Detlev Pollack and Gergely Rosta notes (2017). Many critics could be raised against the modernization theories and as well against any one-dimensional theory of secularization, because it is not a single form of transformation, but rather a quite complex one. Rosta and Pollack argues that at least three central social characteristics need to be taken into account when the modernization process is described. First, modernization contains a functional difference, meaning that functions are spread out into subfield – e.g. economic, politics, architecture etc. as Max Weber already underlined. Secondly, modernization means that the social levels of societies are increasing becoming diverging. This means that there are many levels between the individual and the society. Finally, modernization means that each levels or subfield have created different ‘markets’ for competition – such as a religious sub-level, where organized religions are in competition with each other and with New religions (Pollack & Rosta, 2017, pp. 18-33). This revitalization of religion is depended on the multilayered

interdependence in modernity. As explained, among others, by Huntington, modern people need a form of stable community, moral regulations, etc. in the post-communist era. Huntington argues that the revitalization of religion is dependent on this, and it today therefore takes place among two social groups: first, of all people, who have migrated to cities and now have the need for emotional, material and social support, which religious groups provide more than anyone else, while the second group is the broad and new middle class that has risen out of poverty since the early 1990s (Huntington, 2000, pp. 110 -111). The divergence in social levels is here the main explanation according to Huntington. The situation today, when it comes to religiosity especially in the Western and post-communist part of the world, has convinced Peter Berger in his later publications that the secularization thesis was not accurate. He denied his initial hypothesis and revised his starting points. Berger today argues that the evidence of today's world point, with some exceptions, towards the fact that religion still plays the same role as before (Berger, 2008). The revitalization of religion in the 1980s falls. We would argue, together with two important social transformation that took place with far-reaching effects on many parts of the social life, and even religion. These two transformations could best be described as globalization and neo-liberalization. It is our opinion that religion has partly been revitalized as part of these social phenomena, and that the transformation of societies today by these two trends has affected the religious vitality to a certain degree. Our assumption is that many central factors influence the vitality of religiosity in form of its ability to remain and be stable in societies. In this paper, we will focus on how religious identity are affected and transformed in the processes of globalization and by the idea of neoliberalism. This question has often been treated with respect to the West as underlined by Martikainen et al.:

“In the West, the advent of neoliberalism combined with consumerism coincided not only with the deepening crisis of the welfare state [...] During the same period traditional religion continued to suffer a steep decline. [...] These changes coincide with intensifying globalization. Globalization is a cultural phenomenon, with interlinked social, political, economic and religious dimensions” (Martikainen et al., 2012, p.1).

The open question is then, what about Eastern and Central Europe? In this article, we will strive to point out the difference and the similarities between the effect of neoliberalism and globalization on religiosity between Eastern and Western Europe. By doing so, we might come closer to, which main determinates of neoliberalism and globalization has an influence on religiosity regardless of cultural context – or if it is to context depended to say anything on such a general level.

Religion- The Guardian of Identity

In literature from the broad field of humanities and social sciences the topic of globalization dominates. This is despite the very concept of globalization is mainly related to the economy, but other parts of societies has been impact by the transformation caused by globalization, so the theme has become interesting for many fields. In regard to other part of society, globalization have had its own unique polysemic outlines that have influenced culture, politics, and religion. The very concept and definition has caused many scientific controversy and arguments. One wing in this discussion (the skeptics) sees globalization as the post-modern form of imperialism from the West, while others (hyper globalists) see it as a sign of the growing interdependence of societies caused by progress in technologies and trade. Here globalization becomes, the embodiment of a new set of historical necessity and the creation of a cosmopolitan culture (Brdar, 2001). The hyper globalists view on the world tend to be one where the nature of the technological, cultural, political, and ecological interdependence prevails. The basic idea is here that the interdependence in the end will create a global economy without borders and with a universal culture that neutralizes differences, and where the gap between the rich and the poor will be reduced. Đuro Šušnjić remarks in regards to this idea: “In this way globalization shows its two faces: equalization in relation to economy and the manifestation of diversity in the cultural area of societies. Any pressure from the Western model of economic life, social order and cultural policy has its limits” (Šušnjić, 2015). Creating a transnational culture is to some extent seen as a

trend for many organized and traditional religious communities. Such a culture could mean the extinguishing of the particular values and beliefs of certain religions. This would mean the creation of a structure that transcends the nation – a culture that becomes transnational, a global idea. Globalization is in this way undermining the concept of nation. The transnational culture could be one that competes with the universal and traditional religions, and therefore is it viewed as a threat by many of them.

Originally religious identity was something given by birth, but this has changed in the modern period. Today religious identity is more often something acquired or given through an active choice. Traditionally, religious communities claimed to be the guardians of identity that provided an answer to: who I am and where my place was in the social structure. Here religion is presented in dogmatic terms and as something unchangeable. Religion could not be questioned, and any question could simply be labeled as blasphemy. Peter Berger, argues, in his book *A Heretical Imperative* (1979) that religion in modernity has become something else and therefore is religious communities forced to transform. Modernity is characterized by the individual choice and religion has become something that one acquires through choice and not through birth. In Berger's opinion, religious communities need to meet this change and transforms, rather than hold on to their former traditional form of authorities. Jung remarks: "The idea of baptism was one, where man did rise from archaic identity to the world, in order to become transformed into being a superior to that very same world. At the height of humanity's use of this idea, baptism became the birth of a spiritual and natural man" (Jung, 1977. p. 337). Here religion was the main determinant for the identity of the individual and community. "If someone changed his faith, he lost his identity – both on an individual and collective level. This was the same as death: one who has no identity, were not considered a living man" (Šušnjić, 1998. p. 393). The transformation pushed by globalization, makes traditional religious communities fear the loss of their former monopolistic influence on identity creation and safeguarding.

Berger's concept, which he calls a Heretical Imperative, a key is given to understand what religious state humans are in, if they pre-

tend to reject all traditional ideas, values, and beliefs. In so, they become a heretic, in that sense, that heresy comes from the Greek word for choosing. Their identity is based on choice. In so, this challenged the traditional religious communities, because the essential elements of religions rely in identity, and in its traditional values and beliefs, which has now become a mere choice rather than a tradition passed from one generation to the next or through the church. The religious community can at best hope to, according to Berger, take part in this heretic process and become a part of the identity creation, in which the religious experience to some extent can play a role.

However, the process of globalization is often identified, by its critics, with the expansion of soft Western power and Western desire to dominate the rest of the world's cultural and political systems. When globalization is seen in this light, it makes sense, why religion is once more put to the forefront of societies and a growing number preserve their attachment to their religion. Religion becomes the guardian of local identity and as a bulwark towards a transnational culture that preserves local traditions, culture and identity of a special nationality, ethnicity etc., which otherwise might be jeopardized. This anti-globalist line of thoughts is often found within the perception of globalism amongst right wing politicians, groups or movements or conservative parts of traditional religious communities, who argue that national disintegration can only be resisted with the upholding of nation states, whose main homogenizing factors would be religion. The process of globalization is seen as a possible threat to national autonomy, which undermines the nation states, its local culture, political system and even organized religion (Dugin, 2004). The traditional religion, in Eastern Europe in form of Catholicism, Islam or Eastern Orthodoxy is seen as a tool to resist Western cultural power and a transnational culture. The New religious movements is the exact outwards sign of this process of globalization and its impact on religiosity, in which transnational religiously and organized religions are possible and created in order for modern man to overcome the new uncertainty of everyday life with disregard to where he lives and which local ethnicity, nation or culture he live in.

These are just some of the transformation of religiosity today, which underpin that religion, religiosity and adherence to orga-

nized religions consequently has become in function in contemporary social-political sphere. These trends affect the vitality of religion at the end of the second decade of the twenty-first century.

Religion and the Welfare State

During the second half of the twenty century in the socialist regimes in East and the Western liberal state-system, several researchers detected the erosion of organized religion and religiosity. In today's post-socialist countries in Eastern Europe, most of the state systems have been secularized and the population has become at a general level mores atheistic due to socialist legacy. The Marxist ideology treated religion as part of man's alienation. Although Marx himself was not explicitly against religion, which is attested in his writing on Theses on Feuerbach and at length in his work *The German Ideology* (1845). He was for a non-religious society. Neo-Marxists understood this position in a rather rigid way in which religion was banned from public, and only allowed in the private sphere. The communist society was ideally one based on egalitarian principles, without any exploitation – which led to anti-religious polices and the confiscation of religious communities' property in many Eastern European countries.

The collapse of the socialist regimes at the end of eighties and the beginning of the nineties of the twentieth century was accompanied by a revitalization of religion along the resurgent national-political formation. The resurgent national-political systems led to a confessional homogenization through its mobilization of religious and national groups in the transition from socialism to whatever form the new political system of the various states took. The transition led to increased public support for organized and traditional religions and therefore a greater connection between states and theses communities, such as the various national Orthodox churches in Eastern Europe. Nowadays religion is in many of these societies seen as the base of identity-formation and as a constituting factor for a community, which integrates the individual into the collective. When conflicts arise – often out of national or ethnic differences or rivalry – religion is used as a mobilization tool towards

the individual in order to make them defend the collective against another collective. In such situation, where a collective's culture and identity are under threat, religion becomes part of the defense for a specific culture or tradition. This is in particular relevant under the transformation caused by globalization, because religious revitalization and rivalry works to some extent against the social process of globalization. Modern Poland is a prime example, because here Catholicism becomes a central mark to the right wing political movements and their political mobilization against broader liberal European values and the EU in general. It is unclear, what the main cause is for religious rivalry says Radovan Bigović, and points to social crises, wars and so on - or maybe it is about the gift and wonder of God that have contributed to it according to Bigović (2011. p. 43).

In summary, the process of globalization has come at the same time as religious revitalization in Eastern Europe. Globalization, conceived as a process that makes the world in "a global village", as McLean famously called it, has forced organized religions to recognize their new social role in preserving particular features (religious, cultural, tradition, etc.) - that we will return to. Religious communities have in that way heard the call from Berger and tried to answer it in a multitude of ways. We will therefore underline that religion now longer play the same social functions as before, but, we think, that it has maintained its central role in societies. However, alongside globalization, there has been some major changes in the economic and political field, which have had an indirect influence on religion. Perhaps most central is the collapse of the welfare state-model in the former socialist countries and elsewhere, which to some extent is intertwined with the rise of neoliberalism.

A Brief History of Neoliberalism

Neoliberalism and the social welfare state are phenomena that were central for the political and economic fields for a good part of the twentieth and the beginning of the twenty-first century. In this part of the paper, we will look closer on these phenomena influence on religion and religiosity. The social welfare state was

formed, especially after the Second World War, as a solution to the disastrous conditions in the capitalistic political systems during the recessions of the 1930s. The system was partly based on Keynesian economical model and the political model of the “New Deal”, as President Roosevelt’s social reforms of USA was named. This model in its various form was based on a compromise between the owners of capital and the labors. Robert Dahl and Charles Lindblom, two central American sociological and politicological researcher in the post Second World War period, had a strong intellectual influence on their time. Their theories argue that both communism and capitalism in their original forms have collapsed at the brink of the twenty century. The only viable path left, as Dahl argues, leads to a mixture of state systems, where democratic and market institutions works together and becomes the foundation of prosperity and stability (Dahl, Lindblom, 1953). The underlining premise was, that free-trade need to be encouraged, and in turn became the basis of the Western foreign polices after the Second World War embodied in the foundation of the World Trade Organization (WTO), International Monetary Fund (IMF), Organization for Economic Co-operation and Development (OECD) and the World Bank. David Harvey noted that after the Second World War, the social-democratic parties began to dominate many European political systems as well as systems based on Christian values. In economic terms, these mostly Western systems created almost full employment, economic growth and the social well-being of citizens. The state power was used in favor of the market process and was often used in intervene in order to advance the market further. The fiscal policies were based on a Keynesian approach and the goal was to achieve full employment, industrial policy, health and education protection, etc. (Harvey, 2012). These liberal systems led to economic growth for the Western countries. When it comes to the socialist countries in Eastern Europe, it must be noted that they did not advance their economical systems to the same extent as the western. The relationship between the people and the regimes were to some extent aligned to social principles and beneficial fiscal policies was not absent. To some degree, various Eastern European countries managed to build a welfare-system with free education, schools and health care after the Second World War, perhaps

most noticeable in SFRY. These systems differed from the western one but did still provide a social system capable of much of the same as the western one. Brian Wilson pointed out that religion's role in these welfare states were dwindling. He detected that that social power, morality and coherence of these states at an earlier stage often were bound to religion. In a modern, bureaucratic and rational world, the states have not a moral and ethical foundation and often does not show any display of need for some sort of metaphysical or religious backdrop. The traditional organized religion had lost their authority over the individual and former common values, tradition and organized belief-systems, practices and values lost their significances (Wilson, 1976, 1982). In the socialist period of Eastern Europe, this process of secularization, as Wilson describes, had a direct impact on the dwindling of religiosity.

Religion was often treated with some sort of antagonism by the political systems of the socialist countries, and the issue were treated differently throughout the states and state systems. At a general level, religion was considered as something that should be separated from the state and political system, according to the Marxist ideology. Often the issues were therefore dealt with through a secularization of the states in which the church was separated from the state and given to some extent of religious freedom. This was, however, often only on paper, and the church organization was often under control of the socialist states as well as religious freedom was delimited. Public rituals were treated as direct attacks on the system and order. Taken into account the socialist social well-fare system, the advance of these systems along with the political pressure must have contributed to the erosion of religiosity in the same manner as the Western systems described by Wilson. The evidence of this erosion is available and attest that the adherence to organized religion from the 1960s was falling while atheism was on the rise. At the end of 1960s atheism was widespread in for example SFRY, as a survey from the end of decade documented. 51 pct. answered that they believed in a God, while only 39 pct. Said they would call themselves as believers (Bacevic, according to Blagojevic, 2005). In Montenegro the figure was even lower, and in the early 1990s, only 12 pct. of the Montenegrins declared themselves religious (Vrcan, 1990).

Wilson was not the first one to note the erosion of religiosity after the Second World War accompanied by the decline of influence the traditional organized religious communities had on societies and social life in general. The decline falls together with the period in which the Keynesian economic policies dominated and the well-fare states were build. The decline lasted until somewhat of the end of the twenty century, when several studies shows evidence of how religion is slowly returning to the societal stage. One of the first well-known book that detects the decline in religiosity appeared already in 1943 and was published by the priest Yvan Daniel and Henri Godin. The book, *La France, pays de mission?* points out the declining religiosity mostly in cities and amongst the proletariat. The very same groups that were most affected by the keynsian economical politics and the differentiation of fields and divergent of social levels.

Data from the end of the twenty century records the erosion of religiosity in the second half of the twenty century. In France, a Catholic dominated country, the percentage of regular church-goes is only around 13 pct. In England the number is only around 3 pct of the population, who regularly participate in religious rituals, although almost 50 pct. respond that the adhere to an organized religion. In Italy, only 20 pct. of respondents attend religious services, while in Portugal the number is around 30 pct. (Jukic, 1997). Noticeable, there seem to be no direct correlation between adherence, believing in God and practicing a religion. The researchers Brus and Volis introduce numbers from a series of other countries, which shows the same trend. Data from New Zealand shows that religious practice is regularly performed by about 10 pct. of respondents, in Australia 20 pct. regularly go to church, and in Canada 31 pct. go to the church weekly, according to records from 1975. If we compare the results from a 1946 survey, where the score was 67 pct., there is noticeable decline (Volis and Brus, 1994). Other studies show the decline in practice. E.g. a study from Britain, shows, that 23 pct. of the respond once a week or a month goes to church, in France the study shows the number is 17 pct. (Davie, 2005). In Demark the official statistical data from the Danish Ministry of Ecclesiastical Affairs shows a stabile decline in official members to the Danish people's Church (the national Lutheran

Church). From 1990 to 2017 the number falls from 89,3 pct. to 75,9 pct. The decline is however partly due to the influx of immigrants in Denmark during the 1990s and to a decline in baptism – most rapidly in the larger urban areas. The same trend is seen throughout Northern Europe, where especially the former national churches are in stable, but slowly decline. This is, however, not an evidence for a growing secularization, but rather a proof of Berger's thesis. The individual are losing their connection to organized religion in the modern welfare-state and the traditional organized religions lose their traditional significance (Vejrup & Iversen 2014).

In Pollack and Rosta's chapter "Between Dechurchification and Religious Persistence" much more data is available on the subject, which shows the same differences between decline in numbers of affiliation, numbers of church-goes and data that shows persistence and growth in other key-numbers on religious activities, especially for New religions. They note, "more influential than their actions [the church's] are usually economic, political, and social processes of change" on the decline in members (p. 133), when it comes to Western Europe. (Pollack & Rosta, 2017, p. 74-142). The case is, however, different in Eastern and Central Europe, where Pollack and Rosta notes the increased numbers of members or affiliates, but a stable decline in church-goes (p. 222-224). They therefore argue, that the rise in members must be attributed to the "dedifferentiation of church and state, the nationalistic nature of Orthodoxy also appears to play a role in the process of religious reawakening in Russia" (Pollack & Rosta, 2017, p. 235). The same argument could be raised for the Orthodox Churches in SFRY, where national identity often becomes equal to religious identity – and as we argue, as an effect of globalization and neo-liberalization of the states.

Turning to Religiosity and the Collapse of Keynesianism

However, this liberal concept of the welfare state began to collapse at the end of the 1960s. This was accompanied by an increase in unemployment, a crisis of capital accumulation and high inflation. The period of the so-called stagflation lasted for nearly a decade, and it was followed by a decrease of tax revenues, an in-

crease in social spending, and a fiscal crisis. The Keynesian economy was left without much room for manoeuvre – and politically speaking there was a dire need for new solutions. The crisis of capital accumulation that hit the world in the seventies of the twentieth century reflected in rising unemployment. Dissatisfaction was on the rise, and according to Harvey, the associations of workers' movements in most of the capitalist countries were moving towards socialist compromise between workers and capitalists. Communist and socialist fractions slowly won power across Europe and it represented a threat to the economic elites (Harvey, 2012).

Neoliberalism was one of the solution to this systemic crisis and can be regarded as a utopian project for the reorganization of capitalism, but from a political point of view, we would argue that it is an attempt to reaccumulate capital and restore the power of the economic elites, and according to Harvey, that attempt is dominant in the practice of the idea of Neoliberals (Harvey, 2012, 36). A group of economists, philosophers and historians, who described themselves as liberals and who were gathered around Friedrich von Hayek, strived to replace Marxist ideas and Adam Smith's theories with new free market theories. Nevertheless, they held on to Smith's idea, according to which the invisible hand of the market is best for redistributing wealth for the benefit of all. Therefore, as argued by John Maynard Keynes, the very foundation of the liberal theory – and neoliberal - has a strong resentment of a state intervention that was current in the thirties of the twentieth century. Neoliberalism opposed the central government planning – and this is in all sphere of a state's social life in which a market can be created. As Pollack and Rosta notes, the very creation of markets in all spheres of society is a part of modernity and therefore is there, theoretically speaking, now boundaries for a Neoliberalization of the state structure. This is the core of the New public management theory, because it supposes that all public or state-run parts can be market-oriented.

Certainly, one should pay attention to the theoretical conception of neoliberalism and its practical application. Hayek, the author of key texts on neoliberalism, believed that at least one generation would pass until the battle against Marxism, Socialism, and Keynesianism was won. The elite, who fiercely fought against the

state intervention, appeared with the aim to increase their own power and capital. The idea of neoliberalism was introduced in the USA and Britain, and in the academic world it was introduced in the theory of Milton Friedman; Hayek won the Nobel Prize for Economics in 1974, and Friedman in 1976. In May 1979, Margaret Thatcher won the elections in Britain with the task of reforming the economy. She immediately declared a conflict with the trade unions; she removed much of the former welfare state guaranteed competitive flexibility on the labour market and tried to dismantle the welfare state and supported the privatization of public enterprises, thus creating a climate for attracting the capital of foreign investors. She emphasized individualism, private property, personal responsibility, etc. opposing any form of social solidarity (Harvey, 2012, 40). Ronald Reagan, who continued President Carter's reforms, through further deregulation, taxation, budgetary revenues, and attacks on trade union, came to power in the USA in 1980. During that period, the European countries that did not have communism as a political system was open for American domination. It eventually became a tactic to deal with the threats of the Communist rebellion, which led the United States to an anti-democratic strategy and co-operation with authoritarian regimes (Harvey, 2012, 46).

Simultaneously with the consolidation of neoliberalism and the weakening of the welfare state throughout Europe, religion returns to the social stage. This correlation seems to be very strong in almost all Western states. A Gallup study from 1976, conducted in the USA, shows that 31 pct. of Americans regard themselves as evangelists. Somewhat later, Jimmy Carter freely speaks about his evangelical Baptist faith during the presidential campaign. By 2000, the number of Baptists rose to 46 pct. in America, including two presidential candidates. One of them is George W. Bush, who became Episcopalian, a part of the Protestant confession (Zakaria, 2004). It is, in our view remarkable, how conservative traditional religion found a suitable ground for an undisturbed mission in times of neoliberal values, such as individualism. It is considered that evangelism has progressed thanks to its strictness and alternative to contemporary culture. Zakaria believes that strictness and morality have powerful psychological attraction in a chaotic world (Za-

karia, 2004, 195). It seems the Berger's heretic call has become a call to return to traditional and conservative organised religions for major groups, as a response to a globalized and neoliberal world order.

Regarding the development of democracy and neoliberalism in the post-socialist countries during the transition, it is not possible to provide a short and full account in full details. Fareed Zakaria gives a short description it in his book *The Future of Freedom - Illiberal Democracy at Home and Abroad* from 2004. But it is crucial in relation to this paper that the neoliberal ideological structure has expanded to all post-socialist countries that are in transition from a socialist economic and political order to another, mostly capitalist neoliberal order. Montenegro is an example of that, which can be witness amongst other in its privatization of many former government owned companies, media and so on. With the collapse of socialism, some values created by neoliberalism are slowly assuming a central role of the political space of post-socialist countries. The social state¹ first began to crack with

¹ For consistency of this paper, it is necessary to point out certain differences between the social state and the welfare state. By researching the given subject, we have encountered the first obstacle in understanding the concept of the social state. In fact, several authors believe that there are certain differences between these two concepts. The social state responds with the concept of "social justice" when it comes to the duty of the state to fairly distribute national income, while the welfare state responds with the concept of "deserved justice". When it comes to another important element, i.e. a guaranteed right to social protection, the difference disappears because both phenomena respond by establishing a minimum living standard and securing the existence to combat poverty (Ravnić, 1996. p. 249, Blahož, 2014). On the other hand, those who emphasize the conceptual difference of these two phenomena say that the social state is a much wider concept than the welfare state. The social state provides an acceptable standard of living for its citizens, who are not able to independently provide basic living conditions for themselves, while the welfare state in its duality refers simultaneously to prosperity and welfare that are its basic meanings, and, on the other hand, it refers to the public social security, through its various forms. It is believed that the syntagma itself was first used by Baron Beveridge in 1911, while he participated in writing the insurance law in the USA during the develop-

the introduction of private property in Eastern Europe - an area, which was not legally regulated at first (the rights of workers were not detected and protected by law). The collapse of the social state means that there are now secure job and ordinary persons can lose their social security at any moment, which would call into question their existence and the existence of their families, and finally it would lead to poverty. One could say that the era of neoliberalism reduces citizens to hardened entrepreneurs; workers are deprived of the possibility of resistance and reduced from a political subject to a "human resource".

It is our opinion among those, whose experience a new economic uncertainty and a further diversification of social layers that religion finds suitable ground for spreading and maintaining its own vitality in contemporary society. Inglehart and Norris prove at the empirical level that human (in)security and poverty can be of fertile ground for an increased religiosity (Inglehart, Norris, 2007). With the advent of neoliberal values, there general picture is, that religiously has increase (World Values Survey², Bakrač, 2013). In the book *The Moral Neoliberal: Welfare and Citizenship in Italy* from 2012, Andrea Muehlebach observes how life is lived in neoliberalism on the basis of extensive field research conducted among members of the working class in communities on the periphery of Milan (Muehlebach, 2012). She thinks that the pride and gratitude the Italian citizens feel towards paternalistic and capitalist employers resemble the deep respect the Americans show to Sam Walton. Muehlebach is also convinced that religiosity and religious feelings play an extremely important role in neoliberal experience. The author warns that religion in Italy serves as an ideological 'supplement' necessary for the undisturbed functioning of neoliberalism. In a certain sense, this is evident in Italy as much as in America: religious organizations manage about one-third of the homeless shel-

ment of the New Deal policy of President Roosevelt. In this paper, we will use both terms, considering that there are no significant differences between these two phenomena, and bearing in mind that the differences are mostly in theoretical approach and consideration of practical public policies in different countries.

² www.worldvaluessurvey.org

ters in America, and about 70% of nursing homes in Italy is associated with the Catholic Church (Muehlebach, 2012). Traditional and conservative religious groups take onto them functions that for a brief period have been bound to the welfare state. In so, the literally assume the welfare functions and become home for the marginalised parts of societies. The social stratification plays into this development, and those groups that are economically or politically marginalised are estranged from the secular state and therefore finds a new place in the traditional religious communities. There are similar experiences in the post-socialist societies. For example, there are more and more soup kitchens in Montenegro, under the auspices of the Metropolitanate of Montenegro and the Littoral, and they do thereby directly create affiliation for its user citizens to the church.

Without wanting to turn the story of neoliberalism into the Old Testament legend about the loss of God's grace and Adam and Eve's expulsion from paradise to the world where they are left to themselves, we cannot help but notice that there is a truth in it. Foucault says that the concept of "the rule of the people", which reaches its climax with neoliberalism, originates from "pastoral power" of the church. Bethany Moreton, in the book *To Serve God and Wal-Mart: The Making of Christian Free Enterprise* from 2009, points out that neoliberalism is closely linked to evangelism in the American South. In this respect, Moreton testifies that the links between Christian universities, global trade and gender-based forms of services provided at the headquarters of Wal-Mart in Bentonville, Arkansas are more important than the theoretical contributions of Austrian economists or technocrats of the World Bank. Instead of theoretical consideration of the link between neoliberalism and spirituality, Moreton discovers in Wal-Mart the specificities that help us solve one of the great riddles of the last fifty years: how and why has the logic of the free market become so closely linked with evangelical piety? Moreton wisely observes that the culture of free entrepreneurship is nothing more than a culture of Christian free entrepreneurship. She explains that this prosperous mega corporation in its early years employed capable people from the Ozarks, a region known for evangelical religion and the decline of agriculture. The conjunction of moral and politi-

cal economy created the norms related to gender, services and consumption, and these norms are an inseparable part of Wal-Mart's meteoric success. The South saw this as a den of vice. In response to that, Wal-Mart was consciously trying to create a Protestant culture of consumption (Moreton, 2009). In that sense Moreton point out a new bound between neoliberalism and consumerism with the rising charismatic and conservative wing of Protestantism, which resembles Weber's classical notion that capitalism and accumulation of capital is bound to a Protestant ethic. In Eastern Europe, it has not been proved that a similar link exists between the Orthodox churches and consumerism, but it would be worthwhile to look deeper into this relationship.

For Dugin (2018; 2014), there are three main political ideologies. The first political ideology is liberalism, and its subject is not a mankind, but an individual. The individual means liberating ourselves from any form of collective identity. Dugin argues, the roots of liberalism lie in religion as a freedom from the Catholic tradition. Therefore, Protestantism is actually the liberation of the individual from the church - collective identity and the establishment of a direct relationship with God.³

Conclusion

As pointed out above, religion does not lose its significance at the end of the second decade of the twenty-first century. On the contrary, religion maintains its position and seems to have survived the secularization process created by the modernization of societies. It is difficult to determine precisely what keeps religion vital and to detect the causes that affect people's attachment to religion and churches. Summarized, we would argue that the two great social phenomena, globalization and neoliberalism, should not be directly identified as the cause of a rise in religiously, we believe that they have a certain role in these processes.

Accidentally or not, globalization and neoliberal economics receive their socio-economic impetus along with the revitalization

³ www.arheofutura.rs/category-1/cetvrta-politicka-teorija-i-pojam-coveka/06/04/2018

of religion. Both processes were created on the basis of religious ideas. It is here about the fact that globalization inherits some of the Christian ideas of universality, and neoliberalism, as we have explained in the paper, can be associated with the parts of the Protestant churches – especially today’s more charismatic and conservative parts. It seems that the logic of the free market becomes closely associated with the American form of evangelical piety – as a heritage of the what Weber identified as the typical Protestant ethic widespread in America. Furthermore, neoliberalism dismantled the welfare state, declared fiscal policy immoral, which in our opinion contributed to social insecurity, further increase in poverty, and that poverty increased part of the population’s affiliation to religion and church. It is nothing new that there are more and more soup kitchens under the auspices of the church. We will often hear the speeches of the church dignitaries who warn of environmental pollution, inhuman treatment of the population, the wave of migrants who leave their homes in search of a better life, and the gap between the rich and the poor is growing. All of this raises the level of insecurity and poverty, political estrangement and economic marginalisation, which can have a great impact on the vitality of especially conservative and traditional religious communities and the attachment of people to religion and church in the modern world.

Literature

- Bakrač, V. (2013). Religija i mladi – religioznost mladih u Crnoj Gori. Narodna knjiga i Miba book: Podgorica, Beograd.
- Berger, L. P. (1973). The Social Reality of Religion. Harmondsworth: Penguin.
- Berger, L. P. (2008). Desekularizacija sveta, preporod religije i svetska politika, MEDITERRAN. Novi Sad.
- Bigović, R. (2011). Pravoslavna crkva i evropske integracije, u. Religioznost građana Srbije i njihov odnos prema procesuevropskih integracija. Konrad Adenauer Stiftung. Beograd.
- Blagojević, M. (2005). Religija i crkva u transformacijama društva, Filip Višnjić. Beograd.
- Blahož, J. (2014). The welfare (social) state, European Union and globalization, u The Lawyer Quarterly, vol. 4 No 3, Prague, str. 182.
- Blum, A. (1990). Sumrak američkog uma, Prosveta, Beograd.
- Brdar, M.M. (2001). Globalizacija i država - Srbija i Evropa. Književne novine, vol. 52, (1-15.jul), br. 1037, str. 17.
- Brown, Wendy (2015). Undoing the Demos - Neoliberalism's Stealth Revolution, Zone Books near futures.
- Dahl, R., Lindblom, C. (1953). Politics, Economy and Welfare: Planning and politico-Economic Systems Resolved into Basic Social Processes. Harper. New York.
- Davi, G. (2008). Religija u suvremenoj Europi-mutacija sjećanja. Golden marketing: Zagreb.
- Dugin, A. (2004). Osnovi geopolitike, Ekopres, Zrenjanin.
- Dugin, A. Četvrta politička teorija i pojam čovjeka www.arheofutura.rs/category-1/cetvrta-politicka-teorija-i-pojam-coveka/ 06.04.2018.
- Fox, J. (2001). Chomsky i globalizacija, Jesenski i Turk. Zagreb.
- Giroux, Henry A. (2011). Neoliberalism and the death of the social state: remembering Walter Benjamin's Angel of History, Routledge, p. 590; unos: <http://dx.doi.org/10.1080/13504630.2011.587310>
- Inglehart, R., Norris, P. (2007). Sveto i svjetovno – religija i politika u svijetu.Zagreb: Politička kultura.
- Harvi, D. (2012). Kratka istorija neoliberalizma, Mediterran, Novi Sad.
- Hantington, S. (2000). Sukob civilizacija i preoblikovanje svetskog poretka, CID. Podgorica.
- Jukić, J. (1997). Lica i maske svetog, Kršćanska sadašnjost, Zagreb.
- Jung, K. G. (1973). Čovjek i njegovi simboli, Mladost, Zagreb.

- Martikainen, Tuomas & Gauthier, François and Woodhead, Linda (2012), "Introduction: Religion in Market Society", in Religion in the Neoliberal Age: Political Economy and Modes of Governance, Farnham: Ashgate.
- Moreton, Bethany (2009). To Serve God and Wal-Mart: The Making of Christian Free Enterprise Harvard University Press, USA.
- Muehlebach Andrea. (2012). The Moral Neoliberal: Welfare and Citizenship in Italy. Chicago: University of Chicago Press. p. 228.
- Pollack, Detlev & Rosta, Gergely (2017). Religion and Modernity: An International Comparison, Oxford: Oxford University Press.
- Ravnić, A. (1996). Socijalna država i država blagostanja, Pravni fakultet, Zagreb.
- Šušnjić, Đ. (1998) Religija I, Čigoja štampa, Beograd.
- Šušnjić, Đ. (2015) Teorije kulture, Zavod za udžbenike, Beograd.
- Valis, R., Brus, S. (1994). Sekularizacija: trendovi, podaci I teorija, u: D. B. Đorđević (ed). Povratak svetog.Gradina: Niš. pp. 55-73.
- Vejrup Nielsen, Marie & Iversen, Hans Raun (red.) (2014), Tal om kirken- Undersøgelse af Folkekirkens aktivitets- og deltagerstatistik [english: data on the Church – an investigation of the People's Church's statistic on activities and members], Det Teologiske Fakultet, Afdeling for Systematisk Teologi, Københavns Universitet, Copenhagen. http://samtidsreligion.au.dk/fileadmin/Samtidsreligion/Oevrige_projekter/Tal_om_Danmark/Tal_om_kirken_downloadversion_feb_15.pdf
- Vrcan, S. (1990). Omladina, religija I crkva, u: Ilić, V.i saradnici (ur.), Oglеди o omladini sedamdesetih. IDIS: Zagreb. pp. 111-150.
- Wilson, B. (1976). Contemporary Transformations of Religion. London: Oxford University Press.
- Zakarije, F. (2004). Budućnost slobode – neliberalna demokratija kod kuće I u svetu. Dan Graf: Beograd.
- www.arheofutura.rs/category-1/cetvrta-politicka-teorija-i-pojam-coveka/ 06.04.2018.
- Socialist Federal Republic of Yugoslavia
 - www.worldvaluessurvey.org
 - www.arheofutura.rs/category-1/cetvrta-politicka-teorija-i-pojam-coveka/ 04/06/2018.

ZORA HESOVÁ
Charles University, Prague

The Paradoxes a Return of Religion to Public Debates and Political Discourses ¹

Abstract

Religion has made a return into European politics, at least if we are to judge from the appearance and increase of religious arguments, concepts and symbols, especially in the politics of right-wing populists. Nations, national traditions are being redefined around religious events, institutions and personalities; public spaces invested with religious symbols. Political identities and struggles are being articulated increasingly in religious, culturalist and civilizational terms. This article aims to describe the most salient features of this recent and flagrant religious turn of right-wing populist politics, and to analyse ways in which religion is used and redefined by new political actors.

Keywords: Religion, Right-wing populism, Catholic Church, Central and Eastern Europe, Culturalism, Christianity.

■ In February 2018 the Hungarian Prime Minister said: “Christianity is Europe’s last hope.”² Poland’s ruling party Law and Justice (PiS) wants to see a Catholic Poland in Christian Europe (Modrzejewski 2017, 29) while its leader Jaroslaw Kaczynski said at a meeting: “If Europe is to be strong, it must be Christian. And today it is anti-Christian and especially anti-Catholic.”³ Both want Europe to be more Christian and want to defend it against Muslim migrants. The notorious Central European duo is not the only politicians who successfully bet on a religious talk: Hans-Christian Strache has brought his party to power with slogans about the West in Chris-

¹ The work was supported by the European Regional Development Fund-Project *Creativity and Adaptability as Conditions of the Success of Europe in an Interrelated World* (No. CZ.02.1.01/0.0/0.0/16_019/0000734).

² ‘Christianity is Europe’s last hope’ says Hungary’s nationalist Prime Minister as he calls for renewed crackdown on migration that ‘advances Islam’, *Daily Mail*, 18.02.02.

³ Kaczyński: Europe Is Anti-Catholic, *Gazeta Wyborcza*, 1. 7. 2009.

tians' hands. And he is not alone: many lesser figures, mostly right-wing populists, more and more often use religious register and symbolism.

Yet, they are not religious zealots or fundamentalists. Orbán has turned to religion during a transformation phase of his Fidesz Party when changed from liberal to a conservative. As a son of a communist, in mid-1990s, he reportedly started to study the workings of a church. He had confirmed on the Lutheran church, remarried his wife in church and had children baptised – and won the 1998 elections.⁴ Nor is Jaroslaw Kaczynski a zealot. His late brother, the former president, was called “the soft conservative”⁵ and Jaroslaw equals the interest of the Church with that of the nation (Kaminski 2016, 114). Other successful populists have even more tenuous relations with religious institutions or with the faith.

The recent return to religion in political discourse seems more paradoxical that it happens also in largely secularized countries without any record of religious controversies in the last decades. It is then logical to ask: How and in what context did religious reference reappeared and more importantly, what kind of religion makes its return? This article will make a case for a qualified “the return of religion” arguing that religion and its place in public space are being redefined by the very usage populists make of it. There are namely several recurrent features that characterise the usage of religious rhetoric; when considered in their context, those references are inherently paradoxical, which allows for qualifying the referenced Christianity in a rather ideological way.

The “Return of Religion”

For decades, since the demise of clericalism at the beginning of 20th century, religion was not a primary political issue in Europe. After losing political and institutional clout, organised religions have also lost believers in the 1960s (McLeod, 2000).

⁴ The rise and rise of Viktor Orban, *Financial Times*, 01/25/2018

⁵ President Kaczynski: The Soft Conservative, *Transitions Online*, 10/25/2005

The first more recent European debate on the role of religion in politics – concerning the mention of Christianity preamble of the draft of a European constitution in 2004 – ended in disagreement. Bigger European Member States were then in favour of a general, secular wording of references to common European values, whereas smaller Catholic countries insisted upon a mention of Christianity in the preamble. The matter remained of secondary interest then, as there were more pressing issues and the constitution project got rejected by France anyhow.

Around 2000, Christianity did not represent a matter for consensus, nor a matter of great contention, yet a first rift was already visible. However, only ten years later, references to Christendom and Christianity abound in unprecedented intensity in all European publics and in ways it was not present in a hundred years. There are at least two factors which brought religion back into recent public debates: migration and populism. Migration made European societies more multicultural and multiconfessional, yet the presence of Islam particularly got increasingly stigmatized. Resulting mostly from labour migration from former European colonies, Turkish, Arab, Asian communities are, generations later, still defined by their perpetually inferior social status, but newly also by a growing perception of a cultural difference. Conflicts in the Middle East led European publics to see migrants from there primarily as Muslims and as Muslims who tend to define and organise themselves. Under the influence of such increased visibility of Muslim communities and of Islam as a religion, public debates tend to revolve again around religious symbols in public spaces (crucifixes, hijabs, minarets, pork-meals in school canteens) and around legally complicated modalities of their regulation. Usually, demands to uphold a secularity of public spaces, which means maintaining them free of religion, clash with the principle of state neutrality and fairness. The outcome leads to a redefined role for religious symbols: habitual Christian symbols get to be redefined as symbols of culture, while foreign (Islamic) symbols as those of religion.

A second factor of the return of religion is growing populism or more concretely, populists' usage of religious difference and symbols. Since the mid-2000s, years symbolised by the French and Dutch rejection of the above-mentioned European constitution,

conservative politics based on national identity and on a widespread rejection of multiculturalism plays a growing political role in elections. More markedly, the recent populist wave, culminating in the “annus horribilis” of 2016 in the aftermath of the so-called migration crisis in 2015, brought a great number of explicit references to religions in media and political campaigning. Rejecting Islam as a larger threat, populist parties took to calling upon a defence of the cultural identity of the Christian majority.

The theme of European cultural identity has entered the strategy of most populist movements in Europe from narrowly anticlerical nationalist to broadly pro-Christian. The new right, identitarian rather than nationalist, tends to transcend ethnic (French, Austrian, Dutch, etc.) nationalism in favour of a European Christian identity, opposed to Muslim immigration and integration. Formerly anti-Semitic FN and FPÖ opt for various degrees of anti-Islamist combined with philo-Semitism. Formerly anticlerical nationalist parties make some openings if not to institutional Churches, at least to Christianity as identity. Western European populists (FN, FPÖ, LN, DVV) and new populists in CE (PiS, Fidesz, etc.) increasingly employ references to “Christian identity” of Europe, “Christian roots” of their nation, to a shared “Judeo-Christian” civilisation, in opposition to Islam, to purported Islamisation of Europe and multicultural undermining of cultural cohesion of the Europeans (Brubaker 2017).

Similarly, substantial is the late return of religion into post-Communist Europe, even to its most secularised parts. Influential populists tend to redefine Polish, Czech, Hungarian, Austrian nationalism in terms of religious – not just ethnic – identity. They turn to religious identities anchored in a national culture and stress the difference with religious cultures of the migrants, call to rally the nation around national religious symbols and attempt to monopolise public space with national - religious symbols like patron saints, historical religious figures, references to past events. The reappearance of religion as a major political topic is especially surprising, as Central and Eastern Europe (henceforth ECE) have been largely secularised by 40 years of atheist regimes. Except for Poland and Croatia, where Catholic church acted as a preserver of national identity, Hungary, Slova-

kia, even Austria and especially the Czech Republic have been largely secularised: church attendance has plummeted, cultural and political influence of Churches waned, and liberal politics did not leave much space for religious arguments and figures. And yet, in all those countries, not just in Poland and Croatia, religion as Christian identity, religious arguments and conflicts over traditional values.

Religious Turn of Central European Populists

Religious arguments come in many shapes, of which several forms stand out: religion is used to (re)define nationhood and mark public space, to give nations a mission explicitly formulated as a defence of a Western civilisation and to conduct politics of morality.

Redefining the nation as Christian

In the conservative nationalist rhetoric of League of Polish Families and the PiS, the traditional moral order of the Nation is notoriously based on conservative Christianity (Casanova 1994, Ramet 2017). Since the interwar period, during which a conservative, Catholic, anti-Semitic nationalism of the National-Democratic Alliance (*endeka*) imposed the narrative of Poles as Catholics (as opposed to liberal, multi-ethnic Poland), Poland got defined as a Catholic Land and the real Pole as *Polak-katolik*, and the role of a national backbone of the Church was reinforced by its opposition to the communist regime (Pytlas, 2016, 86-87). Contemporary populist parties PiS and LPR revive the heritage of the *endeka* reiterating the historical trope of foundational principle of moral unity between nation and Church, contained in recent words of Jaroslaw Kaczynski: "We will protect Polish values that have their basis in faith⁶".

The mild Calvinist Viktor Orbán also based his policies on a definition of Hungarian nationhood as rooted in religion and traditional Christian values. One of the first moves made by Orbán's second government was to amend the constitution, making use of the

⁶ Quoted from Gazeta Wyborcza by B. Pytlas (Pytlas 2016, 96)

constitutional majority of Fidesz after 2010. Besides others, the 2011 constitution makes references to God, Christianity, the fatherland, “traditional values” and the “Holy Crown of Hungary.”⁷ Kaczynski and Orbán do not hide the political role they assign to religion and a commonality of their pursuit. Unveiling a statue to late Kaczynski brother, Orbán said: “We believe Poles and Hungarians have a common path, common fight and common goal: to build and defend our homeland in the form that we want ... Christian and with national values”⁸.

Even in the religiously indifferent Czech Republic and among Austrian populists’ religion and nationalism find their point of intersection. Since 2003, a pilgrimage is held on the day of the martyrdom of Saint Wenceslas Day to Stará Boleslav. The event was recently redefined by the Czech cardinal Dominik Duka as a Day of “Czech statehood.”⁹ In the late 1990s, the Austrian far-right Freedomites endorsed Christianity. Under the new leadership of once religiously mute H.C. Strache, the FPÖ used aggressive islamophobia and make ample references to Christianity in its campaigns (Hadj-Abdou, 2016, pp. 34-36).

Christian symbols abound in electoral campaigns but also in public acts of populist and far-right parties. The redefinition of national politics as religious, Catholic, plays out in attempts of sacralisation of public spaces: populist parties place religious symbols in state institutions such as schools and hospitals, when they are in power, like in Poland (Modrzejewski 2017, 27), or in opposition: from the so-called battle of the Crosses in Auschwitz between 1999 and 2006 – in which crosses were installed to highlight Polish suffering in the Holocaust – to the campaign of Hungary’s original right-wing party Jobbik installing wooden crosses across Hungary, to the new practice of Czech Catholic clergy to publicly bless public constructions, firefighter’s trucks and ambulances.

⁷ Hungary’s parliament passes controversial new constitution, Deutsche Welle, 18. 04. 2011.

⁸ Hungarian prime minister Viktor Orban vows to create ‘Christian homeland’ on eve of election, The Independent, 7. 04. 2018

⁹ „Volby pomohou prosadit umlčovanou většinu, prohlásil Duka ve Staré Boleslavi“, Novinky, 28. 9. 2017

Identity

Religion (Christianity) again stands for identity. European nationalisms show a similar identitarian feature to Western populists, namely as a reference to a shared European Christian, Western identity. Rather than seeking an exclusion of a neighbouring or competing nation, a larger cultural European identity is the central dimension of the new populist nationalism. This European Identity is Christian, as opposed to Islam, and Christian culture is marked as in need to be defended against an invasion of a foreign culture. The archbishop of Krakow, Marek Jedraszewski proclaimed: "Let us pray so that other nations of Europe and the world understand that we need to return to the Christian roots of European culture if we want Europe to remain Europe¹⁰". For Orbán, a Christian Europe was "like air which is all around us; our home in which we feel at home in Christian Europe and Christian Hungary".¹¹

The identitarian feature articulates itself most clearly in the alarmist rhetoric of invasion, overpopulation by strangers and inner decline that the populists purport to stand against in the name of Christian identity and values. Like during the Tatar and Ottoman invasions, "Christian Europe" needs to be defended once again. The defence of Christian identity of Europe develops in two main directions, as a defence of: Christian or Western Civilisation and as a defence of a "traditional morality" against the dangers of liberalism.

The Bulwark myth

The medieval messianic myth of the bulwark of Christendom (antemurale Christianitatis) was most extensively exploited by Viktor Orbán, who vowed to keep the migrants out of his nation's borders "to keep Europe Christian."¹² In his OpEd to the FAZ, on the day Angela

¹⁰ Two Europes clash over Islam and Christianity, Israel National News, 16. 10. 2017. online: <https://www.israelnationalnews.com/Articles/Article.aspx/21141>

¹¹ Election 2018 – Orbán Makes Final Appeal To Voters, Daily News Hungary, 30. 3. 2018. online: <https://dailynewshungary.com/election-2018-orban-makes-final-appeal-voters/>

¹² Hungarian Leader Rebuked for Saying Muslim Migrants Must Be Blocked 'to Keep Europe Christian', The New York Times, 3. 9. 2015. Available at:

Merkel allowed migrants to apply for asylum in Germany, Viktor Orbán wrote: “Let us not forget, however, that those arriving have been raised in another religion, and represent a radically different culture. Most of them are not Christians, but Muslims. This is an important question, because Europe and European identity is rooted in Christianity. Is it not worrying that European Christianity is now barely able to keep Europe Christian? If we lose sight of this, the idea of Europe could become a minority interest in its own continent”¹³ – voicing concern in a register that would not have been possible for Western politicians then. In similar logic the Polish Catholics activists have organised a mass outdoor prayer “for Europe” in the forests on southern and eastern borders of Poland in October, extending a symbolic giant rosary around Polish homeland – on the anniversary of the battle of Lepanto in 1571, in which Christian fleet defeated the Ottoman navy.

Yet the bulwarks myth is not only present in countries with a border history, in which it is easy to revive memories of war with Tatars and Ottoman armies. In other countries, Islamophobia provides a source of civilisations’ discourses of the defence of the “West” (Hesova 2017, 161-163). In the Czech Republic, not only populist and far-right parties, but also some mainstream politicians have legitimised the talk of “Muslim flooding” and the “suicide of Western civilisation” (Hesova 2016 b, 32). In Austria, the FPÖ has conducted campaigns with slogans such as “Abendland in Christenhand” (the West in the hands of Christians) and “Pummerin statt Muezzin” (church bells, not muezzin) (Hajd-Adbou 2016, 38).

Morality Debates

Moreover, the Europe to be defended is now defined in religious and culturalist terms. In the populists’ discourse in Central Europe, ‘Europe’ does not stand for a Western, Atlantic orientation of their countries after 1989 or for liberal universalism it used to repre-

https://www.nytimes.com/2015/09/04/world/europe/hungarian-leader-rebuked-for-saying-muslim-migrants-must-be-blocked-to-keep-europe-christian.html?_r=0

¹³ Viktor Orbán, quoted from Frankfurter Allgemeine Zeitung, 3 September 2015 on his official site on: <http://www.kormany.hu/en/the-prime-minister/the-prime-minister-s-speeches/those-who-are-overwhelmed-cannot-offer-shelter-to-anyone>

sent. Rather, PiS, Fidesz and FPÖ understand themselves as the champions of the 'real' Europe, a Christian Europe of traditional conservative values, free of both migrants and of corrosive individualism and liberalism, in need to be defended this time from inner enemies too. In this vision, Polish and Hungarian, Austrian and Croatian populists picture themselves as the only defenders of what makes Europe European: the Christian identity against expansionist Islam and social conservatism against self-defeating liberalism. While the 'fight' against Islam remained mostly on a rhetorical and symbolic level, social conservatism proved to have a much greater political potential. Right wing populists have used the 'defence of traditional value' argument for enacting a broad range of campaigns whose aim was to redefine norms and to alter laws in a series of domains: reproductive rights and abortion homosexual marriages, sexual education in schools. Croatia and Slovakia had held referenda on a binding definition of marriage as heterosexual (successful in Croatia, failed in Slovakia); the Polish conservative government has tried to toughen the ban on abortion and everywhere populists attack so called 'gender ideology'. The politics of morality represented a venue for introducing religious arguments into politics, or rather into the framing of politics – through the insistence on absolute, transcendental values and in the name of so-called war of culture (Petković 2013). Polish Catholics denounce the liberal "Civilisation of death", meaning 'anti-human' permissiveness towards "AIDS, abortions and euthanasia" of the immoral West equated with the EU (Pytlas. 2016, 98). At the national pilgrimage previously mentioned, even the Czech cardinal Duka spoke for the 'silenced majority' that is "manipulated and controlled by some minority's caprices", referring to subject of immigration, feminism, and family.¹⁴

The bulwark myth has two sides: it calls for defining Europe as Christian in its identity, and for legal articulation of conservative values that are defined as traditional Christian ones. Yet when Orbán says: "Christian identity is what is supposed to serve as the glue of Western civilisation", or "Christianity is Europe's last hope... The West falls as it fails to see Europe being overrun"¹⁵ – his usage of the term Christianity

¹⁴ Volby pomohou prosadit umlčovanou většinu, prohlásil Duka ve Staré Boleslavi", *Novinky*, 28. 9. 2017

¹⁵ Hungary's Orban calls for global anti-migrant alliance with eye on 2018

is in many ways astounding. It is not very clear how Christianity is supposed to save Europe from migration, or on what Orbán refers to. Similarly astounding are religious slogans at far-right, nationalist, militarist rallies. For example, when tens of thousands Polish nationalist and dozens of European far-right activists celebrated Poland's Independence Day in November 2017, combining the rejection of migration to 'white' Europe and banners depicting a falanga or a call stating: "We want God".¹⁶ Right-wing populist parties and right-wing groups converge in their readiness to use Christian symbols and concepts. But the way they use them allows for doubts whether the 'religious turn', in the words of Leila Hajd-Adbou, of the far-right does really represent a return of religions in the public sphere. The reason is that the above-mentioned forms of populist campaigning are hardly a reference to public religions for a number of inconsistencies. Before asking what populists do with religion, it is useful to elaborate those inconsistencies first.

Paradoxes of Populist Uses of Religion

The usage of religion in political discourse is paradoxical in many ways. It is sometimes secularist, often supra-confessional, rarely in tune with religious institutions and often in conflict with religious hierarchy. Populists sometimes offer a superficial or even a surrogate national religion. They all understand religion as culture and they all adopt civilizational rhetoric of identitarian Christianity.

Populists Against the Church

The first paradox is that the populist turn to religious symbolism does not in any way mean a return to clericalism or seeking to reinstate the Church into a position of influence. Even right-wing populists, especially in Western Europe, are often secularists, like the champion of aggressive *laïcité*, Marine Le Pen, or the liberal

elections, Reuters, 18. 02. 2018, <https://uk.reuters.com/article/uk-hungary-election-orban/hungarys-orban-calls-for-global-anti-migrant-alliance-with-eye-on-2018-elections-idUKKCN1G20PX>

¹⁶ 'White Europe': 60,000 nationalists march on Poland's independence day, The Guardian, 12. 11. 2017, available at: <https://www.theguardian.com/world/2017/nov/12/white-europe-60000-nationalists-march-on-polands-independence-day>

secularist, Geert Wilders. In CEE, some are secular representatives of various forms of conservative traditionalism (like Marion Le Pen, Jaroslaw Kaczynski, etc.) or politicians formerly indifferent to religion who recently start to use a religious symbolism (Viktor Orbán, H.-C. Strache).

Most conspicuously, even those populists who show an attachment to religious language and symbolism, do not have any firm backing in religious institutions. There are several reasons for that. Some have a record of anticlericalism and their usage of religious slogans is denounced as superficial or the mixing of politics and religion as detrimental to the Catholic Church, so that they earn a rebuke by representatives of Churches. The Czech populist Tomio Okamura was rebuked by his Catholic brother¹⁷; Heinz-Christian Strache was criticised by the Vienna archbishop, Cardinal Christoph Schönborn. He expressed the view that “The cross should not be politically ‘abused’ as a ‘fighting symbol against other religions, against other people’” and that the slogan “Abendland in Christenhand” is unacceptable.¹⁸ Such an explicit rebuke, similar to what the British BNP got from the Anglican Church, is nevertheless rare.

Other populists do not refer explicitly to a specific Church when using religious languages, especially when they operate in a multi-confessional state such as Hungary and Czech Republic or at least appeal to multi-confessional constituencies. They then refer to a supra-confessional Christianity. Viktor Orbán, the nominal Calvinist, lavishes Catholic Church with state money and refers to a Christian homeland; the nominal Catholic, Strache socialises with the sizeable Serb Orthodox electorate in Vienna whose symbols he wears (orthodox prayer bracelet in the FPÖ colours).¹⁹

Quite often populist rely on a sympathetic part of the Church, yet their usage of religious symbols is not generally endorsed by the institution. Populist usage of religion leads then, to a division between the nationalist, politicised part of the Church (like in Poland and Croatia) that sometimes does not reflect official positions of Rome on one hand, and the part that prefers to remain out

¹⁷ Hayato Okamura: Z Tomia se stal tvrdý populist. Mám o něj strach, MF DNES, 24. 07. 2016

¹⁸ Kardinal Schönborn liest Strache die Leviten, Die Presse, 21.05.2009

¹⁹ Radikal und radikal gesellt sich gern, Der Standard, 7. 7. 2010.

of politics or that openly engages with the challenge populism represents for its moral and religious standing, on the other. The division inside the Church was visible during the refugee crisis in 2015 where the Christian injunction of hospitality, reiterated by pope Francis, was taken up by large parts of Austrian and German churches, Catholic and Protestant alike, which did not happen almost anywhere in Central Europe. When hospitality was publicly upheld by a state institution, it was offered to Christian refugees in Czech Republic, Slovakia and in Poland.²⁰

Culturalisation of Religion

The populists' frequent reference to religion leads to giving the notion of Christianity or Catholicism specific meanings. The populists indeed redefine religion in multiple ways: first as cultural identity in a culturalist register, and as a marker of a Western civilisation in a civilisationist register – in CEE in sometimes surprising ways.

The phenomenon of a culturalisation of religion has been observed before, especially in Western Europe (Brubaker 2017). There, the development of the multicultural fact led first to call for protection or at least of a recognition of migrants' cultural identities. In a context of migration issues that were increasingly construed through the lens of cultural difference, the role of a 'national culture' got redefined. In a remarkable turnaround, in the culturalist rhetoric the culture of the majority became a subject for protection and of privileges. Populist engaged in discourses on culture in need of protection or privilege rather than in a discourse on religion – in ways in which one religion could never have been privileged over another one. Culturalism, the tendency to ascribe a group a set of almost hereditary attributes, is being applied to the (silent, vulnerable and unselfconscious) majority. In the populist discourse, religions get to be culturalised – that is, defined as a set of symbols defining the boundaries of groups or the dominance of a group over a territory.

²⁰ EU states favour Christian migrants from Middle East, EUObserver, 21. 08. 2015

At the same time, Christianity has been in a process of being officially recognized as a European heritage in a cultural sense for a number of years, under the influence of inner-European mobility and work migration from outside Europe. Catholic crucifixes were problematized not by Muslims, but by foreign atheists (in Italian Tyrol) and by foreign protestants (in Bavaria) in courts. In the famous case *Lautsi vs. Italy*, the ECHR famously saved the crucifix in public schools against Italian state secularism by declaring it as a cultural symbol. Through the debates ensuing from mobility and migration, Christianity gets to be defined as a European heritage worth protection against both culturally different others and against secularism. Since 2006, symbols were almost 'weaponized' in what is increasingly called culture wars by conservative politicians like the German interior minister, Horst Seehofer: they are matter of identity and culture.

Yet in the populist discourses in CEE, the culturalisation of religion goes even further, towards a nationalisation of religion too. There is a sometimes a confusion on what symbols are to get privileges – Christian symbols or national symbols. In Croatia, Christianity also gets implicitly nationalised, although not in a neo-paganist way. Right wing national parties, identified by their Catholicism, use the semi-official notion "*crkva u Hrvata*" – Church of the Croats for Catholic Church, that spread in the 1970's. For Vjekoslav Perica, this highlights the idea that the independent nation and the Church are intimately linked (Perica 2007, 312). Beyond the Catholic identity of the Croatians, there is a tendency among nationalist politicians (the late F. Tudjman) to promote some kind of 'national Catholicism'. In Poland, the LPR represents a "Catholic–nationalist vision" of the country (Mesežnikov 2008, 78).

Poland and Croatia are two countries in which national identity has been built around the most important national institution, Church. Therefore, the nationalisation of Catholic identity is hardly surprising. A much more extreme example of politicisation of religious identity is Viktor Orbán. Fidezs populism takes freedom of using religious symbols "in an eclectic way" (Zoltán Ádám and András Bozóki, 2016b, 136), and of combining Christian and pagan symbolisms, the cross and the Turul bird. According to Zoltán Ádám and András Bozóki, Orbán's populist discourse aims to 'Christianise'

pagan tradition of the Hungarians, and at the same time, in a kind of neo-paganism, to offer a 'surrogate' religion: "a nationalist and paganized understanding of Christianity and elevates the concept of ethnically defined nation to a sacred status" (Zoltán Ádám and András Bozóki, 2016a, 98).

Finally, even in countries in which the Church or Christianity have not taken such a nation-building role, religious reference gets also culturalised through the reference to cultural difference of Islam in Islamophobic rhetoric of right-wing populists. The highlighted cultural difference with Islam (or pro-immigration, value-deprived liberalism) is constitutive of the populist use of Christian symbols: they oppose Islam as patriarchal, authoritarian, non-rational and ascetic culture. At the same time such discourse builds up an understanding of Christianity as a culture too, negatively defined by the culture of the "others" (Hesová 2016), especially by liberal values such as free speech, gender equality or at least some women rights, personal autonomy, rule-free consumption and self-indulgence. While such a cultural definition scarcely reflects many other "values" usually attached to by Christianity (neighbourly love, compassion, hospitality towards strangers), it sometimes takes an opposite, non-liberal, traditionalist form. "Christian culture" would mean an opposition to "corrosive", individualist liberalism, that would make Europe weak face to face with culturally "strong" Muslims.

Culturalised religion is hence inherently ambiguous: some highlight liberal trends (women rights, self-indulgence), other socially conservative ones (heterosexual marriages, opposition to abortions). Unlike a religious (i.e. theological) discourse, a culturalised Christianity lends itself to be used by politicians in the above-mentioned politics of morality: it allow areligious populist figures such as H.C. Strache and Tomio Okamura to engage in a talk on religion. They define Islam as an ideology, rally against its symbols (mosques, hijabs and niqabs) and support native religious markers of public space. Hence, largely unspiritual, areligious figures without any theological depth are authorised to religious talk simply by reducing religion to common-denomination culture. Such a reduction leads to almost comical redefinitions of Christian identity in the collateralised sense as the largest common denominator,

the folklore: from French anti-Muslim happenings around “apéro, vin, saucisson, pinard” (drinks and sausage) in 2010²¹ or “vepřo-knedlo-zelo”, a Czech pork meal used as a symbol of resistance to purported Islamisation by a Czech retiree anti-Muslim activist.²²

Civilisation Instead of Nation

Cultural difference and culturalised religion are not the only salient features of the new populists’ “religious” talk. Their discourses on religion – on Islam and on the national religious identity – get inscribed into a wider frame than that of the nation: to that of a civilisation. In the populist discourses of PiS, Fidesz, FPÖ etc., the “clash of civilisations” has been given another lease of life, as they take up Huntington’s centrality of religion in a definition of “civilisation”. Their new “master-frame” is the *preoccupation with Islam* (Brubaker, 2017, 10), where Islam is the civilisational rival and Christendom is the West. Indeed, anti-Muslim rhetoric can be found among all right-wing populists and it is the larger context within which Christianity as identity and as culture has gained its recent salience. Only, in new context supersedes that of nation and nationalism (rivalry against a close other) into a larger context of civilisation (rivalry against a distant other).

The opposition to Islam leads also to an inscription of a cultural identity in a hierarchy of values and in a hierarchy of civilisations, where the West now includes all those who oppose Islam: Christian Europe and Israel. The civilisationist discourse makes ample references to the rather young concept of a Judeo-Christian tradition²³ – a phrase mostly criticised by religious Jews, Muslims and Christians for diverse reasons.²⁴ Older populists, such the Front National and the

²¹ À Paris, un “apéro saucisson et pinard” aux relents racistes crée la polémique, France 24, 17. 06. 2010

²² Oldřich Lukáš: Výzva k záchraně ČR před násilnou islamizací, *Parlamentní Listy*, 3. 3. 2015

²³ Andrew Preston, A very young Judeo-Christian tradition. Our country’s religious identity is a surprisingly new -- and it hasn’t always meant what it does now, <https://www.bostonglobe.com/ideas/2012/06/30/very-young-judeo-christian-tradition/smZoWrkrSLeMZpLou1ZGNL/story.html>

²⁴ See: Arthur Cohen, *The Myth of the Judeo-Christian Tradition: And Other Dissenting Essays*. Schocken Books, 1971; R. Bulliet, *The Case for Islamo-*

FPÖ have indeed abandoned formerly often expressed anti-Semitic sympathies in favour of anti-Islamism and pro-Israel politics, while being aptly cultivated by Israel. The so-called Jerusalem Declaration of 2010 is an expression of the European far right's shift towards Islamophobia in which German, Austrian, Belgian, Swedish right celebrate Israel as the front line against militant Islam.²⁵ This from racism (and anti-Semitism) to culturalised religion (and anti-Islamism) helped the mainstreaming of former fringe ideologies into populist parties many of whom had electoral success.

Paradoxically may be, the Western civilisation is construed also around a central value of secularism, as opposed to authoritarian, backward Islam, portrayed as unable to separate between religion and politics (Brubaker 2017, 11). The cultural Christian identity can be used to defend secularist ideology in France, the Netherlands and in Denmark, for example. It also allows for largely secular, anti-Islam parties to attract so called militant cultural Christians (*kämpferische Kulturchristen*), who see a historical and cultural role to Christianity but do not necessarily practice. According to a study in Austria, their share among supporters of the two right wing populist parties is especially high (47% at BZO and 43 at FPÖ).²⁶

In post-communist Central and Eastern Europe, secularism is hardly an explicit feature of right wing populism, and anti-Semitic rhetoric proved to be more persistent in a weaker culture of political correctness. Still, in CEE also anti-Semitism ceased to be a permanent feature of populism, at least in its racist, ethnic forms. The recent Viktor Orbán's electoral campaign with its new foe, George Soros, must have been aware of its anti-Semitic undertones. Yet, as observers of Hungary highlight, the thrust of the campaign was directed at the perception of a liberal, elitist, multicultural conspiracy against native Hungarian identity. The campaign was apparently supported by Benjamin Netanyahu, with whom Orbán maintains good relations (Krekó, Enyedi 2018, pp. 47-48).

-*Christian Civilization*, Columbia University Press, 2004

²⁵ Farid Hafez, „Shifting borders: Islamophobia as common ground for building pan-European right-wing unity“, in: *Patterns of Prejudice*, 2014 Vol. 48, No. 5, 479–499

²⁶ Farid Hafez, Amena Shakir (eds.)(2012), „Religionsunterricht und Saekularer Staat“, *Frank und Timme*, pp. 87-88

Conclusion: Redefining Religion: Identitarian Christianity

There is no doubt that religion has made a comeback into politics, especially into right-wing populist campaigning in Central and Eastern Europe: in right-wing, populist discourses, national memories are re-centred and mobilised around Christian symbols and events, national identities redefined as Christian and national mission as those of defence of Christian Europe and throughout CEE public debates are being engaged around morality issues termed in a quasi-religious language of traditional values.

Yet the religion bears several paradoxical features: it is scarcely a “substantive” religion that gets engaged, but more often a system of symbols defining belonging (without believing, see Brubaker 2016). Populists are often rebuked by Church institutions or their political usage of religion that, at least create a split within them. The religion expressed by populist rhetoric is most often a culturalised religion, that is, a culture of a group defined by shared national, cultural, religious and sometimes folkloric or consumption features. In more extreme cases, non-religious politicians appeal to a kind of supra-confessional system of Christian codes or even to a sacralised collection of national, pagan and Christian symbols in a token “surrogate religion” (Z. Adam).

It can be said that populists instrumentalise religion into a form of a civilizational and identitarian “*Christianism*”. The term has been applied to right-wing populism recently by Rogers Brubaker, referring to the usage of religion by notorious populist like Donald Trump and Pim Fortuyn. The term construction is parallel to the notion of “Islamism”, but it does not intend to be its equivalent in Christianity. Clearly, no elaborated form of fundamentalism and political ideology is present in here mentioned instances of populist identitarian Christianity and no political theology. Still, identitarian Christianist discourses are nurtured by perceived cultural clash and culturalism. They elevate the cultural marker (us – native European, Christians) into a political principle of discrimination (against them, Muslims, immigrants) and into a tool of mobilisation. Hence, like the Islamists, identitarian Christianists borrow parts of religious national symbolism to use them for political purposes.

Unlike in Western Europe, where liberalism and secularism allow to clearly conclude that religion is being instrumentalised by secularist politicians, the case for showing how Central European politicians do so must be made of different grounds. To a large extent, Central European populists exaggerate other features of identitarian Christianity as shown above: its polarizing effects on society and Church; its culturalism and its civilisationist rejection of non-Western others. One of the many worrying consequences of identitarian Christianity has to do with religion: in public spaces it is now populist who give religion its meaning and place in society, who define religion as a cultural code used to exclude other, who, in the words of Oliver Roy now have ownership of religion and who “hijack” it.

Literature

154

Hesová

- Brubaker, Rogers. (2017a). Between nationalism and civilizationism: the European populist moment in comparative perspective, in: *Ethnic and Racial Studies* 40(1):1-36.
- Brubaker, Rogers. (2017b). The New Language of European Populism. Why “Civilization” Is Replacing the Nation, *Foreign Affairs*, December 6, 2017.
- Camus, Jean-Yves; Lebourg, Nicolas; Todd, Jane Marie. (eds.) *Far-Right Politics in Europe*. Cambridge, Massachusetts: Harvard University Press.
- Casanova, José. (1994). *Public religions in the modern world*, University of Chicago.
- Hadj-Abdou, Leila. (2016). The ‘religious conversion’ of the Austrian populist radical right, in: Nadia Marzouki, Olivier Roy and Duncan McDonnell (eds). *Saving the People: How Populists Hijack Religion*, London: Hurst & Company.
- Hesová, Zora. (2017). Problém s islámem: Tři vstvy protiislámského diskurzu a jejich kontext, in: B. Ostřanský (ed.): *Islamofobie po česku*, Praha: Vyšehrad.
- Hesová, Zora. (2016a). The Mainstreaming of Islamophobia in the Czech Republic, in: *4Liberty.eu*, 2016/4, 130-143.
- Hesová, Zora (2016 b) Tschechien: „Kein Land für Migranten“, in: *Welt Trends* 117, pp. 28-33, Potsdam.
- Péter Krekó, Zsolt, Enyedi. (2018). Orbán’s Laboratory of Illiberalism, in: *Journal of Democracy* 29 (3):39-51.
- Thomas, Kaminski. (2016). Radicalism, Populism or Nationalism? All Three in One, in: *4Liberty.eu*, 2016/4, 130-143.

- McLeod, Hugh. (2000). *Secularisation in Western Europe, 1848-1914*, New York: St Martin's Press, 2000.
- G. Mesežnikov, O. Gyárfášová, D. Smilov. (eds.) (2008). *Populist Politics and Liberal Democracy in Central and Eastern Europe*, Institute for Public Affairs Bratislava.
- Minkenberg, Michael. (2017). *The Radical Right in Eastern Europe*, Palgrave Mc Millan.
- Modrzejewski, Arkadiusz. (2017). Catholic and Nationalist Populism in the Current Poland, *Perspective politice*, Bucharest.
- Pankowski, Rafal. (2010). *The Populist Radical Right in Poland: The Patriots*, Routledge.
- Ramet, Sabrina. (2017). *The Catholic Church in Polish History*, Palgrave.
- Vjekoslav, Perica. (2006). The most Catholic country in Europe? church, state, and society in contemporary Croatia, *Religion, State and Society*, 34:4, 311-346.
- Petković, Rafal. (2013). Politike moralnosti – politička slika kulturnih ratova u Hrvatskoj, in: *Političke analize*, Vol.4 No.16 .
- Pytlas, Bartek. (2009). *The Diffusion of Radical Right Ideology in Central-Eastern Europe: The Case of Poland and Slovakia*, paper presented at the 5th ECPR General Conference.
- Stanley, Ben. (2016). Defenders of the Cross, in: Nadia Marzouki, Olivier Roy and Duncan McDonnell (eds). *Saving the People: How Populists Hijack Religion*, London: Hurst & Company.
- Zoltán, Ádám and András, Bozóki. (2016a). State and Faith: Right-wing Populism and Nationalized Religion in Hungary, in: intersections. *East European journal of society and politics*, 2 (1): 98-122.
- Zoltán, Ádám and András, Bozóki. (2016b). 'The God of the Hungarians', in: Nadia Marzouki, Olivier Roy and Duncan McDonnell (eds). *Saving the People: How Populists Hijack Religion*, London: Hurst & Company

KJELL MAGNUSSON
Uppsala University, Sweden

Religion and Nationalism in Bosnia, Croatia and Serbia – A Structural Equation Model

Abstract

The purpose is to discuss the relationship between religiosity, national ideology and ethnic distance, based on a sociological survey undertaken in Bosnia and Herzegovina, Croatia, and Serbia. Religion is regarded as a multidimensional phenomenon, as is nationalism. In accordance with classical theories on nationalism and social identity theory, a distinction is further made between ethnocentrism and nationalism proper. In order to answer the question whether there is an association between on the one hand religion, and on the other nationalism and ethnocentric attitudes, the method of structural equation modeling has been used. An initial model where ethnocentrism is regarded as an independent dimension was compared to an alternative model where it is understood as an integral part of nationalism. The analysis compares both religious traditions (Islam, Catholicism, and Orthodoxy) as well as different cultural and political contexts (Bosnia, Croatia, and Serbia).

Keywords: Religion, Nationalism, Ethnic Distance, Dimensions of Religiosity, SEM (Structural Equation Modeling).

Introduction

■ The Yugoslav wars in the 1990s were sometimes referred to as religious conflicts, and even if this may be a simplification, religion is a major ethnic marker in an area where people are using what is essentially the same vernacular. It is, therefore, natural to ask to what extent there is a relationship between nationalism and religion in Bosnia, Croatia, and Serbia. This issue will be addressed relying on data from a sociological survey carried out in 1999.¹

¹ A preliminary sketch was presented at a conference in Uppsala (Magnusson 2004). Other topics of the investigation have been discussed in Magnusson 2001, 2005, and 2012.

There were about 7,000 respondents, 2,000 each in Croatia and Serbia (except Kosovo), and 3,000 in Bosnia and Herzegovina. Data were collected by the agencies Puls in Zagreb and Medium in Belgrade. The samples are statistically representative in Serbia and Croatia. A multistage random sampling procedure was used in Bosnia. Interviews were made in Bosnian, Croatian or Serbian, using a questionnaire of 98 items.

The analysis is based on *Structural Equation Modelling* or *SEM*, a statistical method permitting the study of theoretical concepts, such as religion or nationalism, through an analysis of relations between *manifest* and *latent* variables, uncovering causal relations and structural features. An important role in the development of SEM was played, among others, by Karl Jöreskog and Dag Sörbom at Uppsala University, who also developed the software LISREL (Karmi & Meyer 2014). In this case the computer program EQS constructed by Peter Bentler has been used (Byrne 1994, Bentler 2006, Bentler & Wu 2008).

Assumptions

A basic assumption is that both religion and nationalism are complex, multidimensional phenomena which may be considered as latent constructs or factors, expressed empirically as beliefs, emotions, or behavioural aspects.

Another assumption is the difference between nationalism and ethnocentrism. Today nationalism is often understood as a synonym of xenophobia, and it is argued that we must not divide society into “us” and “them”. While it is true that one cannot endorse ideologies like racism, it is pointless to say that we should not classify people as “us and them”, since we are doing that all the time. According to Tajfel's *Social Identity Theory* (Tajfel 1974, Turner 1987), the same processes which constitute our identity, i.e. social categorization, comparison and the quest for psychological distinctiveness, also create a certain distance towards members of another group. Defining myself as someone, I am inevitably different from others, and experiments have shown that even arbitrary identities give rise to processes of social distancing. This is a general feature of social life and concerns all types of groups. It is a social-psychological *mechanism* which is distinct

from *ideologies* emphasizing qualitative differences between members of cultural or social groups, and it does not inevitably result in serious social conflicts (Brewer 2001).

We may also point out that the classical literature on nationalism, discussing the rise of national movements in the 19th century, recognize the existence of groups known as peoples or nations, without necessarily equating this phenomenon with chauvinism (Calhoun 1993).

With this distinction in mind, we may construct a simple four-fold table of nationalism and ethnocentrism. In every-day language, by *nationalism* we usually mean a combination of *national rhetoric* and *xenophobia*, while non-nationalism represents the absence of both. However, it is possible to fill in the other fields of the table. For example, we traditionally speak about *patriotism* with is supposed to lack ethnocentric tendencies. It may also be argued, that there is a kind of *invisible nationalism*, i.e. xenophobic attitudes which are not expressed in a national rhetoric.

Figure 1. Nationalism and Ethnocentrism

		Ethnocentric Attitude	
		No/Low	Yes/High
National Rhetoric	Yes/High	"patriotism"	Nationalism
	No/Low	Non-Nationalism	"invisible nationalism"

Nationalism = National belonging as idea and value, expressed in a specific *rhetoric*.
 Ethnocentric Attitude = distance/hostility towards other groups

A concrete example is the labour migration to Sweden and Slovenia in the 1960s and 1970s. Both were traditionally homogeneous societies suddenly confronted with diverse cultures. In Slovenia, intellectuals were speaking of a serious threat to Slovenian national identity (Mežnarič 1986, Grafenauer 1987), whereas such a rhetoric was lacking in Sweden (Magnusson 1989). Does this mean that Swedes were less "nationalist"? I think not. Due to early nation-building, and the fact that Swedish identity was never questioned or under threat, a symbolic language concerned with the *fate of the nation* was missing. However, the

mechanism discussed by Social Identity Theory does exist, and ethnic distance was expressed in a discourse of modernity and individualism. That is, newcomers were, supposedly, not as advanced as the Swedes, who would assist them in overcoming patriarchal morals and become modern. A type of ethnocentric paternalism, if you wish.

Thus, on theoretical and empirical grounds we assume a difference between nationalism and ethnocentrism. Based on theory and literature on South-Eastern and East-Central Europe, it is possible to make certain assumptions concerning the character of both nationalism in general, and the Balkan variety. Therefore, by *Nationalism* is understood the idea that a people or a nation should have a state of its own, and that most members of a nation would live in that state; but also, an ambivalent view of one's own culture (Plamenatz 1973, Gellner 1983, Kedourie 1993) which is due to historical circumstances and may be interpreted within the framework of social identity theory. In that light Balkan nationalism would consist of at least two dimensions: The *Idea of a Nation*, or Nationalism proper, and a specific *View of History or Self Image*.

Variables and Factors

The two dimensions of **Nationalism** are represented by the following items in the questionnaire:

The Idea of Nation

Every people should have a state of its own.
All members of a nation should live in the same state.

Self-Image or View of History

My nation has only conducted defensive wars.
My nation has suffered more throughout history than other peoples.
My people are not perfect, but its cultural tradition is superior to others.
Similarly, **Religion** has three major dimensions: *belief, behaviour, and experience*.

Belief

Belief in God

Character of belief, i.e. the belief in a personal God
Degree of Conviction or Security of Belief
Belief in Jesus as Son of God [Belief in Muhammad as the Messenger of God]

Behaviour

Attending religious service

Individual prayer

Fasting during Ramadan or before Easter

Reading the Bible or the Quran

Experience

Experience of divine presence in ritual

Experience of divine presence during prayer

Experience of divine presence in nature

Ethnic Distance was measured by a Bogardus-scale, representing various degrees of acceptance of inter-ethnic contact.

“How do you feel about contacts with other peoples (of former Yugoslavia)? Would you accept...?”

A Serb (Croat, Muslim) living in your village or town

A Serb (Croat, Muslims) as a work-mate

A Serb (Croat, Muslim) as a friend

A Serb (Croat, Muslim) as husband or wife of someone from your family

Answers: I would accept, I would not accept

These variables were recoded into summary variables on a five-point scale (0-4) expressing low-high degree of ethnic distance.

Model

Nationalism and religion are thus understood as a set of factors, which may be conceptualized in two ways. Either as separate but inter-related factors, or as a more cohesive factorial structure with distinct dimensions.

The first examples show two factors: *The Idea of Nation*, and *View of History*, which are supposed to be correlated. The other model is a second order factor analysis, that is, the two factors are themselves explained by a factor on a higher level, *nationalism*.

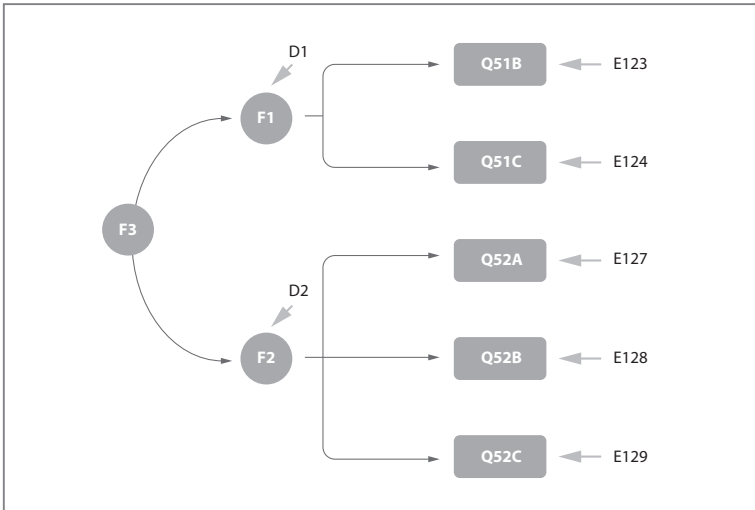
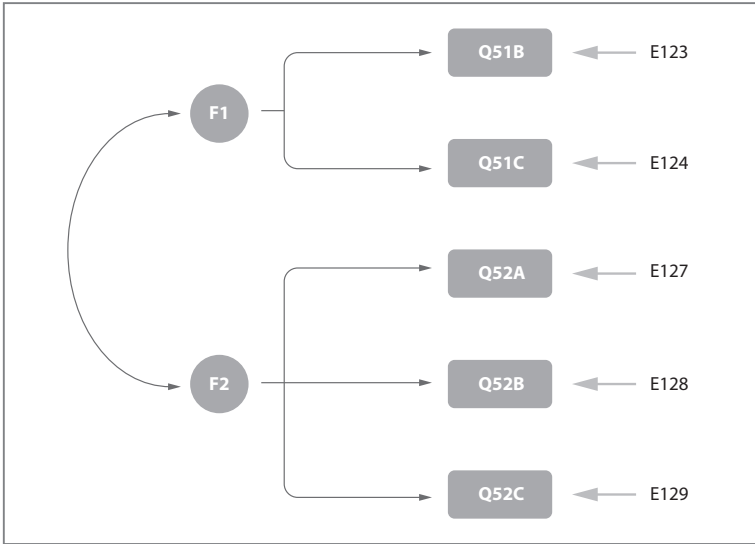

Since we presume that nationalism, as well as religion, are complex multi-dimensional phenomena a second-order factorial solution is presupposed.

It should be stated that the analysis was explorative. There was no earlier research of a similar nature, no established theory or hypoth-

esis that could be confirmed or rejected. Jöreskog has distinguished three ways of using SEM: 1) strictly confirmative, 2) comparison of and modification of alternative models 3) explorative analysis (Byrne 1998:7-9).

This study was of type 2 and 3. The analysis was made in stages, using exploratory factor analysis, before the final model was tested. However, the basic theoretical pattern was there from the beginning.

The respondents were divided into five groups: Bosniaks,² Croats, and Serbs in Bosnia, as well as Croats in Croatia and Serbs in Serbia, altogether 6,570 respondents. We may thus compare similarities and differences between religious groups in Bosnia and Herzegovina, but also between Catholics and Orthodox in different countries. The model was tested for each group separately.

The main features of the model are:

Religion is a second order factor, formed by the three first order factors belief, behaviour and experience.

Nationalism is a second order factor, based on two factors, i.e. attitude towards the idea of nation, and self-image or view of history.

Ethnocentrism is postulated as a first-order factor measuring ethnic distance towards two groups: Muslims vs Croats and Serbs; Croats vs Muslims and Serbs; Serbs vs Croats and Muslims.

The Model is presented in two figures, one simplified, which intuitively illustrates the major relationships between factors and variables, another, using the conventions of EQS. Manifest variables are the questionnaire items (Q), whereas latent variables are factors of different orders (F). Errors (E) and disturbances (D) are also accounted for. Straight arrows represent causal effects, curved lines associations.

In a SEM-analysis, there are two models. A measurement model, which deals with the relations between manifest and latent variables, and a structural model showing the relationship between latent variables. The task is to estimate whether the postulated model corresponds to the relations that exist between variables in the data-set. The plausibility of the model is dependent on measures of goodness of fit. Two such measures will be used: a) Comparative Fit Index (CFI) and b) Root Mean Square Error of Approximation (RMSEA). Note that robust measures will also be provided, due to the character of the datasets.

² In the survey 40 % of the Bosnian Muslims declared themselves as Muslims, and 60 % as Bosniaks.

It should finally be said that missing values have been treated according to Bentler's method for pairwise deletion (Bentler 2006:275-300).

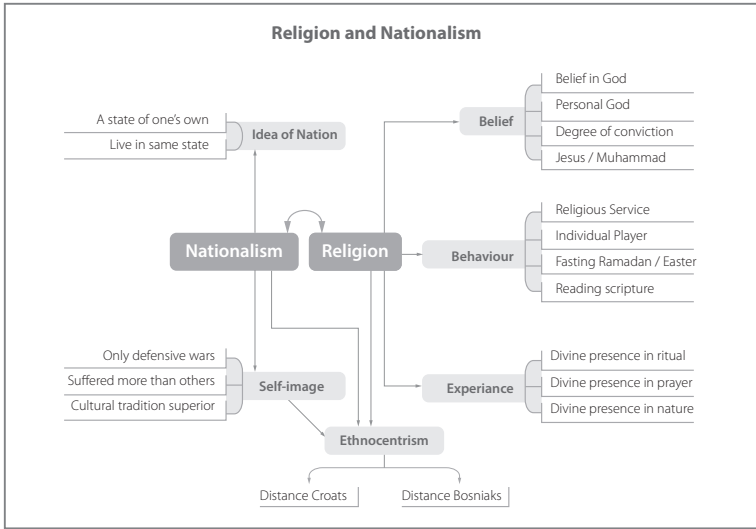

Figure 2. Religion, Nationalism, Ethnocentrism. Simplified SEM-Model

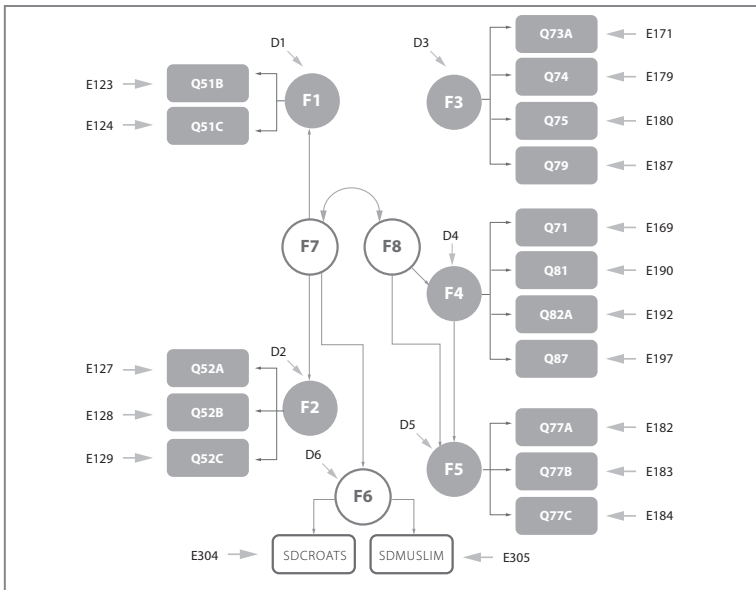

Figure 3. Religion, Nationalism, Ethnocentrism. EQS Model 1

Results

Details for the five groups are found in tables 5 - 9. Initially we will look at the results concerning Serbs from Serbia.

At first the proposed factors emerge. All items supposed to join do so. That is, the theoretical factors are reproduced according to the model.

Second, both religion and nationalism may be understood as second order factor structures.

Third, the three constructs nationalism, religion and ethnocentrism are related.

Fourth, nationalism is more strongly related to ethnic distance than to religion, and the correlation between religion and ethnic distance is weaker than between religion and nationalism. In other words, religion does not seem to be a primary source of ethnocentrism.

Table 1. Factors Nationalism: Serbs in Serbia

	F1	F2
Every people should have its own state	.615	
All members of a nation should live in the same state	.875	
My people only conducted defensive wars		.554
My people suffered more than others		.827
My people not perfect - cultural tradition superior		.773

Table 2. Factors Religion: Serbs in Serbia

	F3	F4	F5
Belief in God	.797		
Believer – Atheist	.836		
Security of Belief	.937		
Belief in Jesus son of God	.597		
Attendance Religious Service		.643	
Individual Prayer		.810	
Fasting before Easter		.569	
Reading the Bible		.509	
Experience of Divine Presence in Ritual			.777
Experience of Divine Presence in Prayer			.786
Experience of Divine Presence in Nature			.562

Table 3. Second order Factors: Serbs in Serbia

	F6	F7	F8
F1 Idea of Nation		.541	
F2 View of History/Self Image		.669	
F3 Religious Belief			.862
F4 Religious Behaviour			.996
F5 Religious Experience			.856
Var. Distance Croats	.996		
Var. Distance Muslims/Bosniaks	.826		

Table 4. Correlation between Factors: Serbs in Serbia

	F7 Nationalism	F8 Religion
F8 Religion	.163	
F6 Ethnocentrism	.646	0.95

The same general patterns do appear among Bosnian Muslims, Croats, and Serbs, as well as among Croats in Croatia (Tables 7-9 and Model 1), although in some cases a single indicator of a factor has been left out³. Still, we find the same hypothesized factor structures, and the latent variables religion, nationalism, and ethnocentrism are, indeed, associated. Again, ethnocentrism is more closely related to nationalism than to religion, and religion is closer to nationalism than to ethnocentrism. However, we may note a clear difference between, on the one hand, Serbia and Croatia, and, on the other, Bosnia and Herzegovina. The relationships between religion and ethnocentrism, as well as religion and nationalism are stronger in Bosnia, although the association religion/nationalism is relatively high in Croatia. This seems natural in a situation of ethnic conflict, especially if religion, not language, is the most obvious symbol of national identity.

To be reasonable a model should have a CFI value of at least 0.90, preferably 0.95. The RMSEA is acceptable if below 0.08, good if below 0.06, and better if around 0.04.

³ This is the case for religious ritual and religious experience among Croats in Croatia and Bosnia, and Serbs in Bosnia. The items concerned were experience of divine presence in nature, and reading the scripture.

Model 1 Religion, Nationalism, Ethnocentrism: 3 F and 2 F solution
 Factor Structures and Goodness of Fit Measures

	Bosniaks	Croats	Serbs	Croats	Serbs
Correlations	Bosnia	Bosnia	Bosnia	Croatia	Serbia
Nationalism/ Ethnocentrism	.794	.469	.602	.454	.646
Religion/ Ethnocentrism	.569	.415	.420	.195	.095
Religion / Nationalism	.590	.499	.506	.477	.163
CFI	0.961	0.956	0.930	0.961	0.957
RMSEA	0.050	0.054	0.079	0.049	0.053
Robust CFI	0.961	0.946	0.937	0.963	0.966
Robust RMSEA	0.041	0.037	0.058	0.047	0.045
Religion/ Nationalism	.635	.615	.629	.471	.163
CFI	0.963	0.957	0.943	0.968	0.963
RMSEA	0.049	0.054	0.066	0.044	0.051
Robust CFI	0.964	0.944	0.948	0.970	0.971
Robust RMSEA	0.040	0.037	0.053	0.039	0.040

Nationalism Second order factor [Idea of Nation & View of History]

Religion Second order factor [Belief, Behaviour, Experience]

Ethnocentrism First order factor [Summary variable Ethnic Distance]

Solution 2: Ethnocentrism included in Nationalism.

In Model 1 two alternative solutions are compared. The first one, which we have discussed so far, treats ethnocentrism as a dimension independent of nationalism, while the alternative model postulates that ethnocentrism, is an integral part of nationalism. If we look at the measures of goodness of fit, the results are not clear-cut. While our hypothesized model is good, it does seem that the alternative solution, according to the CFI and RMSEA measures is somewhat better.

Does this mean that our original hypothesis – ethnocentrism is distinct from nationalism – is not valid? Not necessarily. In general, from a theoretical point of view, the three-factor model is reasonable. Our first example is a minimal model of two dimensions of nationalism and

three dimensions of religion, related to each other and to ethnic distance. That religion consists of belief, ritual and experience is a starting point in all discussions on religious dimensions. Further, the nationalism factor reflects the original understanding of nationalism as a phenomenon, as well as the peculiar ambivalence characterizing what Gellner called "Habsburg and further east-nationalism", i.e. the national movements of Central Europe and the Balkans. It is remarkable that a similar structure appears in all five cases, although with elements of differing strength. This is particularly true of the self-image or view of history.

One reason for the ambiguous outcome might be that the study was undertaken in a situation of ethnic mobilization and war, and that, consequently, ethnocentrism increases and becomes part of a highly salient national ideology.

Moreover, this tendency may be affected by the measurements used. A Bogardus scale measuring distance towards explicit groups in serious conflict is perhaps less adequate than a more abstract scale of ethnocentrism, avoiding direct references to Serbs, Croats, Bosniaks, or Albanians. The items of the questionnaire were, however, not suitable for a comprehensive approach of that kind.

The differences between the two models are not very large, and, consequently, theoretical issues would be decisive. An important point is that the model distinguishing between ethnocentrism and nationalism is more differentiated. If we compare the initial solution with the alternative model – where ethnocentrism is included in nationalism – the association is apparently influenced by the strength of ethnocentrism, hidden behind the concept of nationalism, as it were. As a result, the connection between religion and nationalism is somewhat exaggerated. In other words, the first model gives more information than the second, and should, due to its theoretical relevance, not be easily dismissed.

What one could do is to add variables and/or concepts, or otherwise modify the approach. We made the following modifications. At first, ethnocentrism was treated as a second-order factor. Second, the summary variable of ethnic distance was replaced by a) the acceptance of Bosniaks, Croats, Serbs living in one's village or town, and b) the general attitude towards a given group (I respect them; I have nothing against them; I do not like them; I hate them).

The new model is illustrated in Figure 4. The results are provided in Model 2.

Figure 4. Religion, Nationalism, Ethnocentrism. EQS Model 2

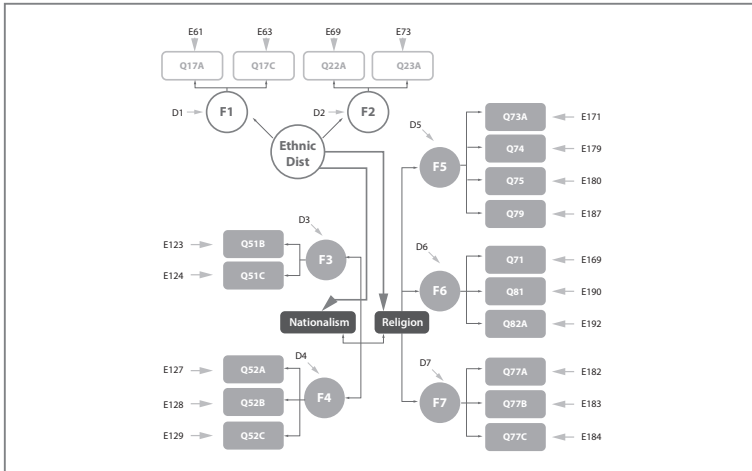

Model 2 Religion, Nationalism, Ethnocentrism: 3 F and 2 F solution

	Bosniaks Bosnia	Croats Bosnia	Serbs Bosnia	Croats Croatia	Serbs Serbia
Nationalism/ Ethnocentrism	.680	.392	.666	.648	.704
Religion/ Ethnocentrism	.302	.348	.588	.147	.151
Religion / Nationalism	.431	.487	.472	.439	.243
CFI	0.952	0.947	0.938	0.961	0.963
RMSEA	0.054	0.056	0.067	0.043	0.053
Robust CFI	0.932	0.929	0.943	0.958	0.960
Robust RMSEA	0.054	0.044	0.057	0.042	0.050
Religion/Nationalism	.399	.577	.607	.246	.195
CFI	0.948	0.931	0.936	0.946	0.959
RMSEA	0.056	0.064	0.067	0.051	0.052
Robust CFI	0.927	0.905	0.941	0.942	0.958
Robust RMSEA	0.054	0.050	0.057	0.049	0.051

Religion Second order factor [Belief, Behaviour, Experience]

Nationalism Second order factor [Idea of Nation & View of History]

Ethnocentrism Second order factor [Attitude towards group & Accept in one's place of living] Solution 2; Ethnocentrism included in Nationalism

When replicating the first model, understanding ethnocentrism as a second order factor, the same pattern emerges, although the strength of individual associations may change. The difference between the respondents in Bosnia and those in Croatia and Serbia persists, and in one case, among Serbs in Bosnia, the relation between religion and ethnocentrism is more pronounced. Further, the relevant indices are generally high, and it is interesting that now the three-factor solution is slightly better than the two-factor model. Our initial model does seem to make sense, but the RMSEA values are lower in the modified alternative.

Concluding Remarks

The analysis has shown that both religion and nationalism may be reproduced as a set of distinct first-order factors, and that a second-order factor model is possible. Especially three findings are interesting. On the one hand it is possible within the structure of nationalism to find a dimension expressing a specific self-image related to the process of nation-building in the Balkans. This syndrome is the same regardless of cultural or religious background and may be explained according to both social identity theory and Gellner's structural view on nationalism. On the other hand, the association between religion and nationalism, or religion and ethnic distance is generally weaker than sometimes supposed, although Bosnia and Hercegovina constitutes a special case. This illustrates the differences between formal religious identity (and the role it has played historically) and actual religiosity. Third, the question of whether to regard ethnocentrism as independent from or integral to nationalism, remains at least partly open.

Obviously much depends on how the latent constructs are measured. This is true not only of ethnocentrism, but also of religion and nationalism. Except the choice of indicators, there is also the issue of dimensions. The present approach was comparative, trying to use the same items to study different groups. This may not be optimal, since characteristic features of, for example, a religious tradition, are not accounted for, or certain aspects may be simplified. In other words, it would be fruitful, on the one hand, to include specific cultural traits, and on the other, to allow for more

indicators/dimensions. For example, religion might include a political and a moral dimension, and nationalism might incorporate the salience of ethnicity and more elaborated aspects of identity and politics.

Ultimately, these issues are related to theory, especially the question whether nationalism *per se* should be treated as a negative phenomenon (Kedourie 1993) or as an inherent feature of modern society (Gellner 1983) which may potentially, but not necessarily, produce serious tensions and conflicts. In a social psychological perspective any type of collective identity, social, political, or religious may, in principle, have opposite effects on society.

It should, finally, be remembered that the results do not concern the strength or prevalence of nationalism or ethnic distance as such. This is a study of how dimensions are *related*, how religion is *associated* with other factors. The case of Bosnia shows that there may be a high or low degree of ethnic distance regardless of the relations between ethnocentrism, nationalism, and religion.

Literature

- Bentler, Peter M. (2006). *EQS Structural Equations Program Manual*. Encino, CA: Multivariate Software, Inc. (p. 275-300).
- Bentler, Peter M., and Eric, J.C. Wu. (2008). "EQS 6.1 for Windows. User's Guide." In. Encino, CA: Multivariate Software, Inc. www.mvsof.com.
- Brewer, Marilynn B. (2001). "Ingroup identification and Intergroup Conflict: When Does Ingroup Love Become Outgroup Hate?" Pp. 17-41 in *Social Identity, Intergroup Conflict, and Conflict Reduction*, edited by Richard D. Ashmore, Lee Jussim, and David Wilder. Oxford: Oxford University Press. (19 s.).
- Byrne, Barbara M. (1994). *Structural Equation Modelling with EQS and EQS/Windows. Basic Concepts, Applications, and Programming*. Thousand Oaks; London; New Delhi: SAGE Publications.
- Byrne, Barbara M. (1998). *Structural Equation Modeling with LISREL, PRELIS and SIMPLIS: Basic Concepts, Applications, and Programming*. Mahwar, New Jersey; London: Lawrence Erlbaum Associates, Publishers.
- Calhoun, Craig. (1993). "Nationalism and Ethnicity." *Annual Review of Sociology* 19:211-239.
- Gellner, Ernest (1983). *Nations and Nationalism*. Oxford: Basil Blackwell. (140 s.).

- Grafenauer, Niko. (1987). "Prispevki za slovenski nacionalni program." (ed) *Nova Revija* 6 (57).
- Karmi, Leila, and Denny Meyer. (2014). "Structural Education Modeling in Psychology: The History, Development and Current Challenges." *International Journal of Psychological Studies* 6(4):123-133. <http://www.ccsenet.org/journal/index.php/ijps/article/viewFile/39901/23136>
- Kedourie, Elie. (1993). *Nationalism*. Oxford: Blackwell. (144 s.)
- Magnusson, K. (1989). *Jugoslaver i Sverige.: Invandrare och identitet i ett kultursociologiskt perspektiv*. Uppsala: Centrum för multietnisk forskning, Uppsala universitet.
- Magnusson, Kjell. (2005). *Experience of War and Views on Violence*. Presentation at the 2nd Meeting on Nordic Cooperation in Genocide Studies, April 1-2, 2005; 32 pp. Copenhagen, Department for Holocaust and Genocide Studies 2005.
- Magnusson, Kjell. (2001). *Distant Neighbours. Perceptions of Self and Other in Bosnia, Croatia, and Serbia* Paper presented at the 6th Annual Convention of the Association for the Study of Nationalities (ASN), 30 pp, Columbia University, 2001.
- Magnusson, Kjell. (2004). *Nationalism, Religion, and Ethnic Distance. Data from a Sociological Survey in Bosnia and Herzegovina, Croatia, and Serbia*. Paper presented at 16:e Nordiska slavistmötet, 21 pp. Uppsala 2004.
- Magnusson, Kjell. (2012). What kind of State? Views of Bosniaks, Croats, and Serbs on the Character of Bosnia and Herzegovina. Социолошки годишњак. Часопис социолошког друштва Републике Српске. Бр. 7. 2012. Стр. 37-62.
- Mežnarič, Silva. (1986). *Bosanci. A kuda idu Slovenci nedeljom*. Ljubljana: Republiška konferencija ZSMS.
- Plamenatz, John. (1973). "Two Types of Nationalism. ." Pp. 22-37 in *Nationalism. The Nature and Evolution of an Idea*, edited by Eugene Kamenka. Canberra: Australian National University Press. (15 s.)
- Tajfel, Henri. (1974). "Social Identity and Intergroup Behaviour." *Social Science Information* 13:65-93. (28 s.)
- Turner, John C. (1987). "Rediscovering the Social Group." Pp. 19-41 in *Rediscovering the Social Group: A Self-Categorization Theory*, edited by John C. Turner, Michael A. Hogg, Penelope J. Oakes, Stephen D. Reicher, and Margaret S. Wetherell. Oxford and New York: Basil Blackwell (21 s.)

Table 5. Bosniaks Bosnia: Factor Structures and Goodness of Fit Measures

Bosniaks Bosnia		F1	
		Nationalism	
Q51B	Every people should have its own state	.628	
Q51C	All members of a nation should live in the same state	.710	
Q52A	My people has only conducted defensive wars		
Q52B	My people has suffered more throughout history than others		
Q52C	My people not perfect but its cultural tradition is superior		
Q73A	Belief in God		
Q74	Believer – Atheist		
Q75	Security of belief		
Q79	Belief in Jesus as Son of God/Muhammad Messenger of God		
Q71	Attendance weekly religious service		
Q81	Individual prayer outside religious service		
Q82A	Fasting during Ramadan / before Easter		
Q87	Reading the Bible / the Quran		
Q77A	Experience of divine presence during ritual		
Q77B	Experience of divine presence when praying alone		
Q77C	Experience of divine presence in nature		
SDCROATS	Ethnic Distance Croats		
SDSERBS	Ethnic Distance Serbs		
	First Order Factors		Second Order Factors
F1	Nationalism	.695	F7 Nationalism
F2	Self Image/View of History	.705	F7 Nationalism
F3	Religious Belief	.703	F8 Religion
F4	Religious Ritual	.985	F8 Religion
F5	Religious Experience	.756	F8 Religion
F6	Ethnic Distance		
	CFI = 0.961	RMSEA	0.050
robust	CFI = 0.961	RMSEA	0.041

F2	F3	F4	F5	F6
Self Image/ View of History	Religious Belief	Religious Ritual	Religious Experience	Ethnic Distance
.515				
.759				
.703				
	.785			
	.893			
	.952			
	.660			
		.700		
		.821		
		.723		
		.641		
			.864	
			.889	
			.599	
				.881
				.783

Correlation, Nationalism, Religion, Ethnic Distance

	Nationalism	Religion	
Nationalism			
Religion	.590		
Ethnocentrism	.794	.569	

90 % confidence interval of RMSEA (0.045 – 0.055)

90 % confidence interval of RMSEA (0.036-0.046)

Table 6. Croats Bosnia: Factor Structures and Goodness of Fit Measures

		Croats Bosnia		F1
				Nationalism
Q51B	Every people should have its own state			.745
Q51C	All members of a nation should live in the same state			.809
Q52A	My people has only conducted defensive wars			
Q52B	My people has suffered more throughout history than others			
Q52C	My people not perfect but its cultural tradition is superior			
Q73A	Belief in God			
Q74	Believer – Atheist			
Q75	Security of belief			
Q79	Belief in Jesus as Son of God/Muhammad Messenger of God			
Q71	Attendance weekly religious service			
Q81	Individual prayer outside religious service			
Q82A	Fasting during Ramadan / before Easter			
Q87	Reading the Bible / the Quran			
Q77A	Experience of divine presence during ritual			
Q77B	Experience of divine presence when praying alone			
Q77C	Experience of divine presence in nature			
SDMUSLIM	Ethnic Distance Croats			
SDSERBS	Ethnic Distance Serbs			
	First Order Factors		Second Order Factors	
F1	Nationalism	.875	F7	Nationalism
F2	Self Image/View of History	.599	F7	Nationalism
F3	Religious Belief	.805	F8	Religion
F4	Religious Ritual	.958	F8	Religion
F5	Religious Experience	.611	F8	Religion
F6	Ethnic Distance			
	CFI = 0.956	RMSEA	0.054	
Robust	CFI = 0.946	RMSEA	0.037	

F2	F3	F4	F5	F6
Self Image/ View of History	Religious Belief	Religious Ritual	Religious Experience	Ethnic Distance
.724				
.853				
.650				
	.774			
	.807			
	.878			
	.587			
		.608		
		.683		
		.675		
		.-		
			.755	
			.755	
			-	
				.765
				.962
Correlation, Nationalism, Religion, Ethnic Distance				
		Nationalism	Religion	
Nationalism				
Religion		.499		
Ethnocentrism		.469	.415	
90 % confidence interval of RMSEA (0.048 – 0.060)				
90 % confidence interval of RMSEA (0.030 – 0.043)				

Table 7. Serbs Bosnia: Factor Structures and Goodness of Fit Measures

		Serbs Bosnia		F1
				Nationalism
Q51B	Every people should have its own state			.808
Q51C	All members of a nation should live in the same state			.679
Q52A	My people has only conducted defensive wars			
Q52B	My people has suffered more throughout history than others			
Q52C	My people not perfect but its cultural tradition is superior			
Q73A	Belief in God			
Q74	Believer – Atheist			
Q75	Security of belief			
Q79	Belief in Jesus as Son of God/Muhammad Messenger of God			
Q71	Attendance weekly religious service			
Q81	Individual prayer outside religious service			
Q82A	Fasting during Ramadan / before Easter			
[Q87]	Reading the Bible / the Quran			
Q77A	Experience of divine presence during ritual			
Q77B	Experience of divine presence when praying alone			
[Q77C]	Experience of divine presence in nature			
SDCROATS	Ethnic Distance Croats			
SDMUSLIM	Ethnic Distance Muslims			
	First Order Factors		Second Order Factors	
F1	Nationalism	.676	F7	Nationalism
F2	Self Image/ View of History	.376	F7	Nationalism
F3	Religious Belief	.837	F8	Religion
F4	Religious Ritual	.947	F8	Religion
F5	Religious Experience	.776	F8	Religion
F6	Ethnic Dis- tance			
	CFI = 0.930	RMSEA	0.074	
Robust	CFI = 0.937	RMSEA	0.058	

F2	F3	F4	F5	F6
Self Image/View of History	Religious Belief	Religious Ritual	Religious Experience	Ethnic Distance
.701				
.698				
.696				
	.751			
	.851			
	.932			
	.571			
		.702		
		.800		
		.673		
		-		
			.858	
			.728	
			-	
				.810
				.921

Correlation, Nationalism, Religion, Ethnic Distance

	Nationalism	Religion	
Nationalism			
Religion	.506		
Ethnocentrism	.602	.420	

90 % confidence interval RMSEA (0.068 – 0.079)

90 % confidence interval RMSEA (0.052 – 0.064)

Table 8. Croats Croatia: Factor Structures and Goodness of Fit Measures

		Croats Croatia		F1
				Nationalism
Q51B	Every people should have its own state			.600
Q51C	All members of a nation should live in the same state			.591
Q52A	My people has only conducted defensive wars			
Q52B	My people has suffered more throughout history than others			
Q52C	My people not perfect but its cultural tradition is superior			
Q73A	Belief in God			
Q74	Believer – Atheist			
Q75	Security of belief			
Q79	Belief in Jesus as Son of God /Muhammad Messenger of God			
Q71	Attendance weekly religious service			
Q81	Individual prayer outside religious service			
Q82A	Fasting during Ramadan / before Easter			
Q87	Reading the Bible / the Quran			
Q77A	Experience of divine presence during ritual			
Q77B	Experience of divine presence when praying alone			
Q77C	Experience of divine presence in nature			
SDSERBS	Ethnic Distance Serbs			
SDMUSLIM	Ethnic Distance Muslims			
	First Order Factors		Second Order Factors	
F1	Nationalism	.710	F7	Nationalism
F2	Self Image/View of History	.787	F7	Nationalism
F3	Religious Belief	.803	F8	Religion
F4	Religious Ritual	1.000	F8	Religion
F5	Religious Experience	.669	F8	Religion
F6	Ethnic Distance			
	CFI = 0.961	RMSEA	0.049	
Robust	CFI = 0.963	RMSEA	0.043	

F2	F3	F4	F5	F6
Self Image/ View of History	Religious Belief	Religious Ritual	Religious Experience	Ethnic Distance
.611				
.795				
.715				
	.683			
	.804			
	.857			
	.608			
		.656		
		.790		
		.494		
		-		
			.778	
			.845	
			-	
				.727
				1.000

Correlation, Nationalism, Religion, Ethnic Distance

	Nationalism	Religion	
Nationalism			
Religion	.477		
Ethnocentrism	.454	.195	

90 % confidence interval of RMSEA (0.045 – 0.053)

90 % confidence interval of RMSEA (0.039 – 0.047)

Table 9. Serbs Serbia: Factor Structures and Goodness of Fit Measures

	Serbs Serbia		F1	
			Nationalism	
Q51B	Every people should have its own state		.615	
Q51C	All members of a nation should live in the same state		.878	
Q52A	My people has only conducted defensive wars			
Q52B	My people has suffered more throughout history than others			
Q52C	My people not perfect but its cultural tradition is superior			
Q73A	Belief in God			
Q74	Believer – Atheist			
Q75	Security of belief			
Q79	Belief in Jesus as Son of God / Muhammad Messenger of God			
Q71	Attendance weekly religious service			
Q81	Individual prayer outside religious service			
Q82A	Fasting during Ramadan / before Easter			
Q87	Reading the Bible / the Quran			
Q77A	Experience of divine presence during ritual			
Q77B	Experience of divine presence when praying alone			
Q77C	Experience of divine presence in nature			
SDCROATS	Ethnic Distance Croats			
SDMUSLIM	Ethnic Distance Muslims			
	First Order Factors		Second Order Factors	
F1	Nationalism	.541	F7	Nationalism
F2	Self Image/View of History	.669	F7	Nationalism
F3	Religious Belief	.862	F8	Religion
F4	Religious Ritual	.996	F8	Religion
F5	Religious Experience	.856	F8	Religion
F6	Ethnic Distance			
	CFI = 0.957	RMSEA	0.053	
Robust	CFI = 0.966	RMSEA	0.041	

F2	F3	F4	F5	F6
Self Image/ View of History	Religious Belief	Religious Ritual	Religious Experience	Ethnic Distance
.554				
.827				
.773				
	.797			
	.836			
	.937			
	.597			
		.643		
		.810		
		.569		
		.509		
			.777	
			.786	
			.562	
				.996
				.826

Correlation, Nationalism, Religion, Ethnic Distance			
	Nationalism	Religion	
Nationalism			
Religion	.163		
Ethnocentrism	.646	.095	

90 % confidence interval of RMSEA (0.049 – 0.056)

90 % confidence interval of RNSEA (0.037 – 0.045)

NADA NOVAKOVIĆ
MARIJANA MAKSIMOVIĆ
Institute of Social Sciences, Belgrade

Social Development, Traditional Religion Movements and Migrants in Europe^{1 2}

Abstract

The subject of sociological and economic analysis is the relationship between traditional religious movements, migrants and social development in contemporary Europe. An interdisciplinary approach to researching these phenomena is unavoidable, and sociology and economics can make a significant contribution to it. Therefore, the authors use a variety of scientific materials, data from official domestic and European institutions and find relevant research on these phenomena. The starting point is: international migration has made a significant contribution to social development, and the role of traditional religious movements in society is changing with globalization. Policies of immigration countries towards migrants of different cultures and religions are changing, which often aggravates (or alleviates) the conflicts between migrants and the local population. In the first part of the paper, research is about the characteristics of globalization, its causes, subjects, dynamics the most important economic, social, political, demographic and cultural consequences. The second part is dedicated to the essence of traditional religiousness. The differences between traditional and new religious movements are outlined. The third part deals with the research of the characteristics of international migrants in Europe, which belong to different cultures and religions. Finally, it is concluded

¹ The research paper is the result of the project 179038 "Modeling the development and integration of Serbia into world currents in the light of economic, social and political movements" financed by the Ministry of Education, Science and Technological Development of the Republic of Serbia, 2011-2018.

² Scientific partner. The research paper is the result of the project 179039 "Structural, Social and Historical Changes of Serbian Society in the Context of European Integration and Globalization" funded by the Ministry of Education, Science and Technological Development of the Republic of Serbia, 2011-2018.

ed that traditional religious movements and migrations have predominantly positive consequences for the immigration country and contribute to economic, social, political and cultural development.

Keywords: social development, Europe, globalization, migrants, traditional religious movements.

Introduction

■ There is a collection of texts called "On the Edge - Living With Global Capitalism" (ON THE EDGE - Living with Global Capitalism)¹. Really, a man is wondering if all living in global capitalism live on some edge? One should live his own life in a fast-changing world, and then the processes of individualization and globalization in the context of real economic and political circumstances are parallel. In contemporary society, when everything is globalized, culture, finance, religion, art, technique, technology, brands, sources of identity are the office (school) and not rarely. The home and family seem to be losing the race with the changes that carry information technology and the frequent migration.

In this paper will be presented old religions, Christianity, Judaism, Islam and Buddhism in today's global environment, as well as freedom of religion. It is followed by consideration of migrants, political, economic, demographic and religious factors of migration, the concept, character, division of modern migrations, as well as social conflicts and migrations. It is justifiable to ask: "Are migrants, old religious movements and social conflicts connected in some way? Are the conflicts of religion, or religious conflict? "

Globalization and Religion

The main bearer of all the changes over the past hundred years is market capitalism coupled with global communication advancement, as it is today the leading form of organizing the world economy and society. The search for new markets is raw, growth in

¹ Editors of this book are Will Hutton and Anthony Giddens, 2003. Plato, Belgrade.

private corporate power also, and as a result, there is an increase in inequality. For example, compensation for those with managerial and technological skills has increased, while that population at the bottom of the scale is exposed to that part of the labor market that is disappearing. However, thanks to globalization, economic development in Asia and Latin America has increased. These countries have benefited from all the advantages of globalization such as facilitating access to capital and foreign markets, transferring technology through internal investment and free information dissemination. They have enabled their countries to accelerate industrialization and increase living standards, through their own planned investment in human capital. So this is the civilization of business that is all more globalizing. However, this situation makes it difficult for companies to maximize the value of their shares, thus creating job insecurity. There is a decline in the role of the welfare state, the impoverishment of certain segments of the society due to the pressure of competition on the bottom of the labor market. "The basic thing about which we agree is that globalization should be taken seriously, it is the agent of economic, social and political transmissions" (Haton, Gidens, 2003 pp.6-9).

***The Globalization and her subjects,
changes and the consequences***

"Globalization is an endless space for the encounter of the worlds that were ignored by each other, at the same time it produces a mess, provokes a historical chaos, leads to a culture that can be a means of understanding among nations, but it can also be transformed into a contrary contrast, a means of destruction has been shown, for example, during wars in the Balkans" (Fuad Alam, 2012 p.13). The most frequently cited factors of globalization are: 1. Accelerated development of technology and technology, and especially electronic revolution, which led to changes in communication, education, leisure time; 2. Collapse of the "world of ideas"; 3. The action of large states and international organizations, so that globalization is a political ideology and a plan of economic powers. Today, the main subjects of globalization are: first, several hundred multinational companies; second, state co-operation through inter-

national organizations, for example, the North American Free Trade Association - NAFTA, the Association of Peoples of South East Asia - ASEAN, then BRIX - the fast-growing economies of Brazil, Russia, India, China and the Republic of South Africa, which are associations of countries that are very significant in the world; third. non-governmental organizations operating all over the world; fourth, a global co-financing role is played by financial insights, such as the International Monetary Fund and the World Bank. The concepts of development and advancement of society are formed in megalopolises in accordance with Western standards of living. Globalization has also brought about major changes that have affected people's lives and the organization of states. Positive changes brought about by globalization are: 1. Rapid progress and the development of science and technology; 2. Fast turnover of goods and new achievements; 3. Facilitated communication between people; 4. Combating many diseases globally; 5. Limitation of illiteracy; 6. Improving the position of women and youth and their increased importance and role; 7. Freedom of thought which fits into basic human rights; 8. Promoting democratic principles; 9. Various forms of people's solidarity that increase the participation of people in the educated world. At the same time, there are the negative consequences of globalization: 1. Deepening the gap between the rich and the poor, 2. A small, economically strong minority with large influences and privileges, which is trying to organize the rest of the population according to their way of life, 3. Millions of people are at the border or below the poverty line; 4. Major labor migration; these large and new waves of migrants flood over prosperous countries. In these prosperous countries, such as Germany, Switzerland, France, Norway, the role of the welfare state is preserved, i.e. welfare states, except that they have a constant need for labor; 4. Uncontrolled use of natural resources that pose a threat to ecological disaster; 5. Increased crime rate, but also corruption; 6. The weakening of the state, democracy, and democratic institutions, the weakening of their strength, authority and efficiency (Atanasije, 2002, pp. 199 - 202).

The above can be summarized by claiming that globalization actually brought a set of changes, but also "interlocking trends", which are: first, the communication revolution around the world; second, establishment of a "light economy" that is globalized,

through the establishment of a knowledge economy, which differs from that in the industrial economy; third, globalization is accelerating after 1989 and the fall of the Berlin Wall; and fourth, the transformation of everyday life in terms of equality between men and women, which represents a global trend and changes family and emotional life. The tendency is that all borders collapse, or at least the smashing, for example, economic and social. The imbalance of power has always existed, but with these changes, it is deepening. Yet this "new age" is a mixture of new possibilities and difficulties (Haton, Gidens, 2003 pp. 11-13). By studying both types of consequences, it has been concluded that they have led to economic, social, political, demographic and cultural changes. For these reasons, the most important research on the consequences of globalization will go in that direction.

The end of the cold war in the world has not brought peace. In many countries war broke out, there are about fifty, and new states have been created that is neither developed, nor underdeveloped, nor are they in a transitional stage, but belong to the fourth category. They are fighting each other, either in civil strife, or have ended a war, and their transitional period lasts several decades. Apart from the war, there are other problems that need to be addressed globally, such as the right to water and water resources, climate change (global warming), new weapons, for example chemical and biological, migration of people around the world, religious conflicts, employment and an increase in social inequality (Atanasije, 2002, p. 203). As Bishop Nikolay Velimirovic said, peace in man begins to spread to society, but the unrest in man begins to spread to society (Velimirović, 2003, p.19)

Traditional religiosity, freedom of religion and the new age

It is justifiable to ask how old religions such as Christianity (Catholicism and Orthodoxy), Judaism, Islam, Buddhism persist in such a world today. It is interesting to emphasize that the current globalization of religions. The globalization of old religious movements - is not the appearance of a recent date. However, when put

in the attitude of the West and the Muslim world, one can see the “contradictory set of attraction and repulsion”. So in both cultures, there was a rejection of tradition, but also of its revival at the same time. Thus, re-Islamisation hand in hand with globalization, and “the voice of the preacher” today, is reaching all the parts of the world. This, of course, did not arise suddenly because the three types of figures can be described at any time: in the nineteenth century it was a philosopher, as an independent individual, in the 20th century, it is an engineer as the carrier of modernity and in the 21st century it is a communicator, as a hybrid expert unavoidable in a global era with the most diverse knowledge in sociology, anthropology, literature, religion and some other areas. But Islam, as the third and last monotheistic religion, has more than a thousand and two hundred million believers is faith, but also a moral code, social, cultural and political practice. Thanks to the media and the global culture of Islam, I tend to globalize². Of course, in different environments, it is interpreted differently, and hence the effort to show this religion through certain rules through the evolution and modernization of Islam and approaching the rest of the world. This could contribute to a correct interpretation of developments in modern Islam in countries with Islamic traditions, but also in those countries where there are large Islamic communities, such as France, Belgium, Germany, Great Britain and Italy. Islamic elites are the result of attempts at modernization and they represent a class of educated young people from traditional families. With this new class of Islamists, a new national class emerged, and the very consequence of transformations that came from rural areas, but separated from them and lived in urban areas³. Therefore, today’s tensions between Islam and the West can be interpreted on a theological, historical, sociological and cultural model (Fuad Alam, 2012, p. 14).

Similar is the case with Christianity. The Western world accepts the belief in one way, and the East in its own way. “... The

² While Western media offer a picture of political Islam, on the other hand, the legs of Islam are reduced to the scriptures (Qur’an, Prophet’s Tradition) (Fuad Alam, 2012).

³ They live in modern cities in poverty, for example in Morocco, Egypt, and Algeria, and militant Islamists are recruited from these layers.

world and man are essentially limited in nature and therefore limited to the truth of Christianity, and since each people and man have their own particular limitations, then his Christianity becomes special" (Florenski, 2007, p. 10). Namely, "Orthodoxy is a global phenomenon today. "Globalization" and "European integration" are not primary issues and are essential for the Church, but there are challenges that it can not ignore. Globalization is immanent to the very nature of the Orthodox Church. The task of the Church is not to deny the "European integration" and the "globalization" of the world, but to interpret and explain them, to tackle the pathology of modern societies. Professor Bigović wrote, believing that Orthodoxy after the communism was renewed and revitalized and that it can rightly be said about the Renaissance in Orthodoxy from the end of the XX and the beginning of the 21st century: "The peoples of Eastern Europe have decided to build a common European home with the peoples of Western Europe" (Bigović, 2010, pp. 183-184). In addition, Judaism and Buddhism, as old traditional religions, have their own characteristics, rituals, and symbols. In Japan, the old religions are Buddhism, Shintoism, Confucianism, and Zen. For example, based on the values of Buddhism, Shintoism was created. Shintoism is the old and official religion of Japan, which, after the Second World War, became a state religion. It is a specific Japanese religion, it has about 106 million members, and it has a lot of influence on Buddhism, Confucianism, and Taoism (Maksimović, 2014, p. 9, Maksimović, 2017, p. 86). However, there are also new religions that involve a whole range of cultures. These new Japanese religions actually represent new religious movements established in Japan, and in Japanese, they are called Shinshukio (新宗教) or Shinko Shukio (新興宗教) (Reader, 2015, pp. 1-2). Under the concept of a new religion, all religious organizations that have been established since the mid-19th century as a "new religion" are classified. The era of modernization, the Meiji period, to this day, is actually an inspirational period for new religious movements in Japan. For these reasons, the term "new religion" refers to a large number of organizations and cultures, and the central personality of each organization is the founder of charisma. However, in the period after the Second World War, and especially after 1970, there are religions that bear the name "new religion" (Raider, 1988, pp. 235-236). It is these reli-

gions that represent an important part of global pluralism. The Japanese religions of this type, with the most supporters, were Agonshu, Sukio Mahikara and GLA (God Light Association), and Jehovah's Witnesses and the Unification Church are also very supportive. These last two were established in other places, but they also arrived in Japan. However, even after 1980, the growth of new aggressive movements continued, such as Kofuku, Kagaku Aum Shinrikyo and Worldmate, and the founders of these religions were young and often well-educated people. Members of these religions are mostly young people, especially individualism. In Japan, there are about 183,000 officially registered religions, but about 2,000 of them have a significant number of supporters. New religions attractive are the feelings of the community they provide because there are people who do not have the support of the family, the local community, or the traditional "old" religions. From this it can be concluded that the old religions are old for centuries, that is, they originate from "antiquities and ancient times", and these new ones originated from the end of the XIX century and in the mid-20th century onwards. Old religions are more based on rituals of respecting faith and love, and new ones on cults and sacrifices. While the old religions basically had a belief and a sense of belonging, and leaders are religious leaders, in new religions, leaders are young and educated people. In old religions, followers are of all ages, and in new religions, followers are mostly young people.

However, as freedom of religion is considered basic human right, this topic is important not only for church and community verses but for society as a whole⁴. "The freedom of belief (religion) for each individual, one of the oldest basic human rights, is one of the greatest achievements in the process of recognizing the individual spiritual freedom of a human being. The legal framework that protects this right in revenge prescribes that any state rules in the religious and philosophical sphere are ignored, and at the same time it offers certain guarantees of manifesting faith to the community of believing individuals" (Kitanović, 2013, p. 43). Namely,

⁴ It is interesting that when the Church can be an employer, because it provides services to the public, it manages public buildings and similar jobs that sometimes exceed the practice of secular institutions (Kitanović, 2012, p. 75).

the freedom of religion is related to freedom of thought and conscience, and each individual has the right to choose and confess religion without interference by the state. The first freedom of religion is the individual right of every individual, and it implies the right of an individual to choose a specific religion, or religion, but also the right to change religious affiliation or conviction. Freedom of religion is prescribed by the Constitution of European countries. Then, it is regulated by the Convention for the Protection of Human Rights and Fundamental Freedoms (May 4, 1950) adopted by the member states of the Council of Europe. In addition, almost all countries of the world accept the International Covenant on Civil and Political Rights of the UN. The European Member States of the OSCE (and the CSCE, the predecessor of the OSCE) also seize the relevant documents of these organizations. For EU member states, the ratification of the Lisbon Treaty implies a greater importance of the EU Charter of Fundamental Rights, which relates to the freedom of thought, conscience, and religion, and is written in the same spirit as the European Convention for the Protection of Human Rights. In addition, the fundamental basis for human rights to freedom of religion is also based on legal sources such as the judgments of the European Court of Human Rights (Kitanović, 2013 pp. 44-45). In addition, the UN has issued a Declaration on the Elimination of All Forms of Intolerance and Discrimination (1981) based on religion or belief. The further development of international legal acts led to binding documents such as the International Covenant on Economic, Social and Cultural Rights (1966, and came into force in 1976) (Kitanović, 2013 p.134).

International Migration and European Union

There are numerous causes of migration. They can be global, regional, and individual or personal. In order for an individual to opt out of finding better living conditions elsewhere, the same causes are commonly occurring at the same time. For example, the safety of life and health, warfare, climate changes, and natural disasters are endangered. and various types of discrimination. Discrimination is often based on differences in race, religion, gender, culture, ethnicity.

Particularly for their devastating consequences is the child's work. "I do not want to use the goods produced by children's work for the sake of my conscience." If there are more such principled attitudes, positive labeling can occur. This is quite feasible. For example, the Germans helped produce the Renmark label, which is treated on carpets in which children were not involved (Bagvati, 2008 p. 166).

European Union and current mass migrations

Mass migrations to Europe from the Middle East and Africa, over the past five years, have shown in the palm all the major problems and weaknesses of the EU. These are, first of all, demographic, political, economic, institutional, cultural, moral and security problems, and they significantly affect the relationship between the domestic and the settled population. The answers to this on the national and European level are different, and often they are mutually uncoordinated. On this occasion, they have summarized in the context of the way in which the EU has accepted (rejected) migrants. Migrants are of different socio-demographic characteristics and belong to different cultural, ethnic and religious groups. Europe is an attractive destination for them, and especially the most developed countries in the EU, in which the "state of the baggage" is preserved. Thanks to new communications and the IT sector, migrants are largely informed about the benefits of living in Europe, which in turn is a democratic, tolerant and multicultural community. Migrants leave behind societies that have been destroyed by war, misery, and natural disasters, or they are preparing to do so. They carry with them a completely different culture, faith, habits, customs, and values. On the way to the desired goal in front of them are numerous obstacles (the most important are political, legal, financial, security). They are set by individuals, groups, national and supranational institutions, most often in order to slow down migration, reduce the number of migrants and then many return them back. In doing so, many international, European and national regulations violate the free movement of people, seriously question the values of solidarity, tolerance, and humanity in general

Demographic data indicate the aging of the European population. The average lifespan in countries that form the core of the

EU has been prolonged, but the number of citizens under the age of 14 has long been lower than those older than 65 years. This gives an extremely high index of aging. The natality is in decline, and the average lifespan is prolonged. This is accompanied by other problems in the field of education, health and social protection of citizens. Germany is a typical example, and that is the country in which migrants want to arrive. In France, the demographic picture is somewhat more favorable, especially in terms of birth rate. The migration from the former colonies is a significant contribution to this. Sweden and Scandinavian countries have a relatively old population. There are relatively less social inequalities there, and the sense of community and solvency is still at an enviable level. New migration significantly improves the demographic structure of the population in highly immigrant countries (France, Germany, Denmark, Sweden). This is indicated by Eurostat data (Milicevic, 2018).

The mentioned characteristics of the population significantly influence the employment policies. They ultimately depend on the type of capitalist economy that dominates in some countries. Overall, the level of activity of the working-able population is relatively high in the EU. The employment rate is also high, and the employment rate of the oldest generations is also increasing. According to Eurostat data, but also the reform of the pension system, there is still room for prolonging the working life. The changes were created under the strong influence of the global economic crisis, as one of the reasons for this. The situation is different from country to country. More than a million workers are missing in the German labor market, which is almost the same as this country received migrants in 2015. In other countries it is different, but the fact that new migrants occupy a place in the informal and gray economy. As they are most often in the best demographic and working age, it will surely rejuvenate the working and other population of the society from which they come.

The global economic crisis has hit Europe. Inequalities between old and new EU members, developed northern and underdeveloped and overdue southern members have grown. The crisis itself has financial, but also political and moral dimensions. All of this was compounded by differences in the interests of states in the euro one and others that are beyond it. With new migrations, it

all made it difficult to solve the systemic problems of this regional community.

At the institutional level, the EU is still an entity on the path from the Confederation to the Federation. This is evidenced by these factors: the way constitution, jurisdiction, the functioning of the most important institutions. Since the beginning of the mentioned migrant crisis, efforts have been made to strengthen transnational institutions. Often, the complicating “democracy deficit” seeks to replace better co-ordination of their work. The greatest success was achieved in the area of the financial system, which alleviated the negative consequences of the debt crisis of the most indebted members. For example, more citizen influence on the election of representatives to the European Parliament (EP), for example, is ensured by changes to the voting system. In addition to this, voters at the national level see it as a second-class event. They do not see a link between their own interests and choosing people for the EP, believing that the procedures are indirect, and the “Brussels administration” is alienated. Hence the turning of national parties and movements, especially right-wing ones (Madenović, 2014, pp. 165, 166; Novaković, 2017, p. 83).

The EU proclaimed the goal of creating a multicultural community, a “European citizen,” whose identity is being built through the process of integration, harmonization, and harmonization of interests. A complex mechanism that seeks to achieve it is not sufficient, because changes in cultural, religious and ethnicity are more complex and longer-lasting. On the ground of today’s Europe there is a mixture of such communities, more or less confronted. There are already decades in Europe and citizens who have a different culture and religion. Most of them came from former colonies (France, Great Britain, Spain) and belong to the Muslim community. Their integration into society has been made more difficult. Events in France in 2005 confirmed that domestic citizens did not accept them at all. Intolerance went into open conflicts, which were only postponed by physical force and stricter laws (Malešević, 2010, p. 192). The educational system has become even more restrictive to the children of other cultural and religious communities, even in France, which has separated the church and the state from the law. In particular, there were turbulent protests against Danish journal-

ists who published in 2005 the caricatures of the Prophet Muhammad, where he was portrayed as a terrorist⁵. This in part confirmed the difference in the cultural and religious identities of the peoples of Europe and Muslims in the east. Religion as a part of cultural identity in them has different weight and meaning. In Muslims, religion regulates the whole way of life, and in Christians, in secularized Europe, it is a matter of personal and private choices. In the name of freedom of speech, this move from the ground has violated the feelings of the Muslims. In the current migrant crisis, these conflicts of members of different cultures and religions became almost every day.

The global economic crisis has hit Europe. Inequalities between old and new EU members, developed northern and underdeveloped and overdue southern members have grown. The crisis itself has financial, but also political and moral dimensions. All of this was compounded by differences in the interests of states in the eurozone and others that are beyond it. With new migrations, it all made it difficult to solve the systemic problems of this regional community.

At the institutional level, the EU is still an entity on the path from the Confederation to the Federation. This is evidenced by these factors: the constitution, jurisdiction, the functioning of the most important institutions. Since the beginning of the mentioned migrant crisis, efforts have been made to strengthen transnational institutions. Often, the complicating “democracy deficit” is trying to replace better co-ordination of their work. The greatest success was achieved in the area of the financial system, which alleviated the negative consequences of the debt crisis of the most indebted members. For example, more citizen influence on the election of representatives to the European Parliament (EP), for example, is ensured by changes to the voting system. In addition to this, voters at the national level see it as a second-class event. They do not see a link between their own interests and choosing people for the EP, believing that the procedures are indirect, and the “Brussels administration” is alienated. Therefore, the turning of national parties and movements, especially right-wing ones (Madenović, 2014, pp. 165-166; Novaković, 2017, p. 83).

⁵ The incident with the editorial board of a journal (author’s note).

The EU as a peace project successfully settled the Germans and the French, the Poles and the Germans, but significantly contributed to the outbreak of conflicts, their dynamics, and results, when participating in wars in the territory of the former Yugoslavia. This has led to the mass migration of the population to those countries and the rest of the world. The new wave of migration to Europe is by far the most massive. Some of the EU member states are directly and indirectly involved in war conflicts in the areas where migrants arrive. National and regional military and political interests are mixed. Some countries within NATO are in the process of destroying states in the Middle East, Asia, and Africa. Others do it alone, to protect "national interests". The third is indirectly engaged, even if the sale of weapons to warring parties. Therefore, there seems to be a somewhat cynical claim that the EU is surprised by the arrival of migrants and the efforts to return migrants into these areas. In this case, the story about the EU as a peace project, a protector of human rights, democracy and multiculturalism is being demolished. Its leaders are aware of this. German Prime Minister Angela Merkel publicly acknowledged this in 2010 and later repeated it (Kazimirović, 2015).

The migrant crisis has undermined the European security policy's shortcomings. The overwhelming dependence on NATO, the absence of common security policies and forces, resulted in ad hoc measures and the reaction of national politicians to protect national interests and the common interests. On one side is the "open door policy" of Germany, which has been relaxed over time. On the other, countries that in the name of national interests and security physically and legally impede the arrival of migrants. "The attitude of state authorities towards migrants was different. It has been prevalent in the use of force, from tear gas, water cannons, to the use of firearms" (Novaković, 2016, p. 238).

In Europe, the secularization process has been furthest and is considered to be the most secularized continent. The Dominance of Christianity, while Judaism and Islam are less represented. Christianity is divided into two confessions: Roman Catholicism and Orthodoxy. The first is dominant and there are three different directions within it (Protestants, Roman Catholics, Lutherans (Blagojevic, 2015, pp. 54, 56). Baseline values are far different from Islam, but the rela-

tionship of these religious communities depends largely on how these Islam is preaching the unity of state and religion, ie there is no original process of Islamic secularization, and therefore there is a great difference between the members of these religions. A review of the behavior of the domestic and migrant population in Europe has confirmed the thesis about the strong resistance to migrants in the countries where Catholicism prevails (Poland, Hungary, the Czech Republic). In countries with a "mixed" religious structure (Germany, France, Netherlands), this was less pronounced. The most interesting are reactions in Scandinavian or "Lutheran" societies, besides Germany, one of the most desirable places for the migration of migrants, precisely because of the strong "state of well-being", but also because of the high salaries. time and vigorous domestic residents, especially members of the right political movements. Finally, the conditions for obtaining asylum are tightened, and the number of migrants remaining in the country is limited.

Migrants between integration and deportation

The right to asylum is a human right protected by international law. According to the Geneva Convention, only fighters and war criminals can deny this right. In reality, it is violated daily. It is mostly denied to current migrants, in the name of national interests, the security of states and the EU as a whole. The Schengen agreement, on the free movement of people in the countries that joined him, proved to be quite insufficient. Its implementation has been suspended for a long time during the migration crisis. These were the most striking indications of raised concrete and wire walls between EU member states and those who are not, and through which migrants pass. In a short time, such obstacles were raised by Hungary, Slovenia, Bulgaria, Croatia, Austria, and the Hungarian Prime Minister's "disobedient Victor Orban" syndrome almost diminished and spread in Europe. The irony of condemnation by European leaders and institutions of the EU is that the European Court of Human Rights in Strasbourg gave the right to Hungary in case of raising the barrier to Croatia. In the meantime, asylum policies are even more restrictive for migrants and non-EU citizens.

The national state's defense against migrants was not only symbolic and declarative. It is most often complemented by raw interventions against migrants by regular police units, special detachments, reinforced border guards and the use of the army. All this was especially hard on the southern borders of Europe, the countries where migrants first arrived. For months, Greece, Italy, and Macedonia have been the scene of domestic and migrant conflicts: Their cry to help them has led to short-term financial assistance and an EU plan to deploy migrants according to quotas. The countries of the "Višegrad Group" did not agree to this, and the EU has no real and effective legal and other mechanisms to sanction them.

A temporary solution to alleviate the migrant crisis was found by the EU in an agreement with Turkey (March 2016)⁶. Turkey has pledged 6.4 billion euros to stop the flow of migrant and achieving this essentially depends on the political will of the authorities in Turkey. The other direction of "resolving" this crisis is that the EU has found it in forming joint coastal guards and patrolling seas with countries in northern Africa (Libya). The third and inadequate is the delay in investing and financial aid in southern Africa, where a large number of migrants come from. Of all the above, it is more important what the EU has not done. It is a withdrawal of military and other moves by its members to exclude themselves from participation in the war in the Middle East, Syria, Afghanistan, Sudan and regions where real and "indirect" wars take place (Gajić, 2015, p. 21). It is part of the geopolitical interests of the great powers, which are the real and systemic causes of the current migrant crisis.

Migrants on the labor market of the EU integrate on different ways. Less educated accept less complex, low paid and risky jobs in the public and informal economy. Those who are more educated, and Germany preferred to do just that, they are doing jobs that lack the domestic workforce. Their arrival means changes in the domestic labor market. Therefore, wages for the same jobs of domestic workers are reduced. They can move to better -paid jobs, and enjoy union and other protection. The emigrant workers do not have this, and they are less and less paid in relation to the do-

⁶ Turkey has been selected because migrants are Muslims, as well as the people of this country.

mestic workforce. A special sub-layer of migrants is made by those who work in the informal economy. The worst situation is for unskilled women and members of minority ethnic and religious groups. Briefly speaking, the economic growth and recovery of the EU countries are contributed by the new migration, so every monetary investment in their arrival is quickly and multiple paid.

“Since migrants are most definitely the most useful to migrants, migrants may even be migrant, and some of the classes of individuals may decline due to migration, both in the country of origin and in the country of destination, it can be prescribed that migrants pay extra taxes. A tax surplus would be used to help those who are losing money due to migration. Or, in this way, migrants would cover the costs that the country of origin had for their education (by transferring money from taxes to those countries). Or immigrants may be required to work at a certain age and at certain intervals in the country of origin. Another option is to allow a significantly larger number of temporary workers, as in Switzerland. The most radical is Posner and Vale (2014). They consider that the admission of migrants, even if they are then exposed to discrimination in terms of labor and civil rights, such as in Qatar, bring poor people to the world much more than the exclusion policies pursued by wealthy countries, justifying that they can not afford to all potential migrants to guarantee the same formal rights. Posner and Wale argue that openness and civil rights are in conflict here and that some kind of compromise is needed: greater openness requires the narrowing of the scope of civil rights. The possible compromises must be discussed, because there is no doubt that such a relationship of research exists” (Milanović, 2016. p.124). It justifiably raises the question of the benefits of migrants and migrations for the countries they come in when a proactive campaign against their immigration is being conducted? The answer to these dilemmas can be found in the following: that global inequalities will continue because “the benefits of globalization will not be evenly distributed” (Milanović, 2016. p. 192).

Cultural integration of migrants is difficult and long-lasting. It also depends on the institutions and policies of the state they came to. Changes are necessary both in the education system and in higher expenditures for other services (health and social care, for exam-

ple). The frequent “ghettoization” of migrant communities in European cities is more evidence that the current policy has been unsuccessful. Especially true for the Muslims. The massive presence of this community in Europe leads to real and normative changes in legislation (family, heredity, etc.). Numerous reports of attacks and terrorist attacks are a warning to both the state and society that diversity must be respected and protected in other ways. For now, it can be said that the state in the EU, even when it comes to migrants, strengthened not as a social but as a security institution.

Thousands of migrants on their way to Europe have lost their lives, especially those who have come to the sea. Others disappeared on the “Balkan” and the other route. The third experienced all the troubles of the “illegal” crossing of the border. Most of those who have arrived in Europe are facing a struggle for survival, and then for the conditions of life and work of a decent man. This is not only a European but also a civilization value. It remains unattainable for all those migrants deported by the authorities to the first country of “arrival” or origin. In short, it turned out that the common political, financial and security action of EU member states is an almost impossible mission. The reaction to mass migrations was untimely, more informal than through common institutions, partial and more in line with the national interests of the most powerful countries.

Conclusion

The conclusion of this paper could go in two directions: that globalization, besides positive and negative consequences, offers new opportunities, and the other direction is that all religions try to globalize. Globalization is full of contradictions. The dependence of states in the world is also enlarged and deepened. However, observing the international economic trends of people, goods, and capital, it can be concluded that they have increased with the interconnectedness of the world. With this, many opportunities for all actors in globalization have been opened. Perhaps the most prominent of them have been used by global companies using it for their increased profits, through moving production and demand for cheap

labor. As religions seek to globalize, the role of traditional religious movements in society also changes with globalization. The issue raises the question of increasing the international activity of the churches of all traditional religions, the issue of ecclesiastical diplomacy, and the question of increasing members and religious supporters around the world. An example can be found in Orthodoxy, which in the last decades has increased the number of its supporters.

Therefore, the text analyzes the most important causes, dimensions and consequences of globalization in the world. It was then emphasized that it was also about the globalization of cultures and religions, old and new social and religious movements. On the example of the EU and migrants, the effects of globalization and the functioning of this regional community are clarified. The essence of the great world religions is clarified. The basic values of the old religious movements and the potential points of their discrepancies and conflicts are outlined. All this is seen in the context of global economic, political and geopolitical changes in the world, and especially in Europe. The most important dimensions of economic inequalities in the world are identified, which are one of the causes of wars and modern migration.

Current mass migrations to Europe are part of the problems that the EU meets with. It as a supranational state has its advantages and disadvantages. Only the demographic, economic, financial, political and security aspects of the functioning of the EU are mentioned here. The characteristics of the societies to which migrants come from the Middle East, from Syria, Afganistan, and Africa are briefly described. The causes of migration are deeper, global and regional, and the consequences for the society in which they come in multiple. For migrants who integrate into a new society, profits are economic and social. Cultural, religious and political integration is uncertain and complicated. All this is often accompanied by intolerance and conflicts of varying intensity between domestic and internally displaced populations. Migrants are exposed to constant pressures, they are less paid, often they are not paid insurance, but they also accept it as better for them, better than the policy of exclusion from participation in social life. The "welfare state" or welfare state remains for its domicile population in those countries where migrants come, and for migrants, it is a "security state". Al-

though migrants are younger, they are largely uneducated and therefore have difficulty integrating them in the labor market, and the countries in which they migrate are daily informed that they do not need their antimigrant policies.

Literature

- Atanasije, Arhiepiskop Tirane i cele Albanije. (2002). *Globalizam i pravoslavlje*, studije o pravoslavnoj problematici, Hilendarski fond pri Bogoslovskom fakultetu SPC: Hrišćanski kulturni centar, Beograd.
- Bagvati, Jagdiš. (2008). *U odbranu globalizacije*, Službeni glasnik, Beograd.
- Bigović, Radovan. (2010). „Pravoslavna crkva i evropske integracije“, *TEME*, G. XXXIV Br. 1, pp.183-195, januar - mart 2010. Niš.
- Blagojević, Mirko. (2015). *Vitalnost religije u (de)sekularizovanom društvu*, Institut društvenih nauka, Beograd.
- Florenski, Pavle, Aleksandrović. (2007). *Pravoslavlje*, Logos: Brimo, Beograd.
- Fuad Alam, Haled. (2012). *Globalni islam*, Službeni glasnik, Beograd.
- Gajić, Aleksandar. (2015). „Građanski rat u Siriji – geopolitički okvir“, *Kultura polisa*, god XII, br. 27, pp. 21-37.
- Hutton, Will, Giddens, Anthony. (2003). *Na ivici – živeti sa globalnim kapitalizmom (On the Edge – Living with Global Capitalism)*, Plato, Beograd.
- Kazimirović, Miloš. (2015). „Merkelova i smrt „multikulturalizma“, *Politika*, 12. 1. 2015, <http://www.politika.rs/scc/clanak/315768/Merkelova-i-smrt-multikulturalizma>, 15. 08. 2018.
- Kitanović Elizabeta, 2013. *Evropske crkve i ljudska prava*, Konrad Adenauer Stiftung, Beograd
- Milićević, Dragovan. (2018). „Deografska slika Srbije i Evrope“, *makroekonomija*, 29. 08. 2018, <http://www.makroekonomija.org/0-dragovan-milicevic/demografska-slika-srbije-i-evrope/>, 1. 09. 2018.
- Maksimović, Marijana. (2014). *Filozofija rada i upravljanja u Japanu*, Institut društvenih nauka, Beograd.
- Maksimović, Marijana. (2017). „Human resources i management and religions in Japan“, *International scientific meeting almanac: Religion i contemporary society*, p. 85-98. Institut of Social Sciences, Belgrade.
- Malešević, Miroslava, (2010). *Ima li nacija na planeti Ribok? Ogledi o politikama identiteta*, Srpski genealoški centar. Beograd.

- Milanović, Branko. (2016). *Globalna nejednakost – novi pristup za doba globalizacije*, Akademska knjiga, Novi Sad.
- Mladenović, Ivica. (2014). „Izbori za Evropski parlament u Francuskoj: kriza evropskog projekta, istorijski poraz levice i uspon ekstremne desnice“, *Izborne ponude i rezultati-izbori u Evropi i Srbiji 2014*, (Zoran Stojiljković ur. et al.), pp. 21-37, Kondrad Adenauer Stiftung & Centar za demokratiju Fakulteta političkih nauka, Beograd.
- Novaković, Nada. (2016). „Migranti, kriza i javni protesti“, U: *Migranti na raskršću ili bespuću zemlje Srbije*, (prir. Jovan Ćirić i Branislava Knežić), pp. 229-240, Institut za uporedno pravo, Institut za kriminološka i sociološka istraživanja, Regionalno predstavništvo ruske humanitarne misije na Balkanu, Beograd.
- Novaković, Nada, (2017). „Desecularization, National State and the Rise of Right movements“, *International scientific meeting almanac: Religion in contemporary society*, pp. 69-58. Institute of Social Sciences, Belgrade.
- Reader, Ian. (2015). „Japanese new religions: an overview“, pp. 1-51, <http://www.wrldrels.org/SpecialProjects/JapaneseNewReligions/Japenese%20New%20Religions.WRSP.pdf>, 26.2.2018.
- Reader, Ian. (1988). „The Rise of a Japanese “New New Religion”-Themes in the Development of Agonshu“, *Japanese Journal of Religious Studies*, 1988, 15/4, pp. 235-261, <http://citeseerx.ist.psu.edu/viewdoc/download?doi=10.1.1.691.2874&rep=rep1&type=pdf>, 26. 2. 2018.
- Velimirović, Nikolaj. (2003). *Iznad Istoka i Zapada*, Glas crkve, Beograd.

NATAŠA JOVANOVIĆ AJZENHAMER
Department of Sociology, Faculty of Philosophy
University of Belgrade

Max Weber on Russia and Orthodoxy: An Analysis of the Collectivist Ethical Basis of Eastern Christianity

Abstract

In this paper, we will focus on the connection between Max Weber's interpretation of political events in Russia in 1905-1907 and after 1917 and his interpretation of Orthodoxy as a collective religion. Although we do not consider that there is a direct causality, this connection can be seen on some examples with positive (when it comes to the compatibility of the democratic spirit of the German and Russian people) or negative connotation (when accusing Russia of cooperation with Serbia beyond every rational geopolitical logic, leading by emotions) with which Weber talks about the relationship between Russian national ethics and the spirit of Orthodoxy. From the point of view of the sociology of religion, it will be interesting to explore why Weber puts Orthodoxy in the same category with Islam and Judaism and separates it from the Western variety of Christianity. This view from the history of sociological theories will be an illustration of how cumulative knowledge is an important part of the study and understanding of contemporary phenomena.

Keywords: Max Weber, *Otherness*, Russia, Orthodoxy, Revolution, Collectivist ethical basis.

Introduction: Max Weber and the Russian and Orthodox Otherness

■ Zygmunt Bauman (1925-2017) reminded us that we do not expect too much from sociological classics when it comes to the study of *Otherness*; identity issues and intercultural relationships occupied philosophers and sociologists in the second half of the twentieth century, while on the transition between the nineteenth and twentieth century the *Otherness* was just a secondary theme

(Bauman, 2004: 16).¹ Guided by this logic, Bauman “defends” from criticism for ethnocentrism those classics that dealt with issues of strangeness and *Otherness* (primarily Max Weber (1864-1920) and Georg Simmel (1858-1918), but also Emile Durkheim (1858-1917)) and reminds contemporary scientists that they should not fall into the trap of non-textualization of classical sociological creativity. It is true that information on other cultures, civilizations and nations was far less accessible than it is today, and that different theoretical concepts that are today controversial from the point of view of modern science were at that time in use, and yet it seems that Bauman’s (though to great extent necessary) note should not be misused to avoid contemporary critical reading of classical heritage. Also, if classical studies in the field of intercultural studies are neglected and proclaimed anachronism, the cumulative nature of scientific knowledge will be lost.

The second reason that we are returning to classical works concerns the disciplinary identity, and this is especially important when it comes to the sociological study of religion. Religions and religiosity can be studied from different angles: theological, philosophical, anthropological or aesthetic; however, if we want to limit the inherent sociological study, or to define what is autochthonous sociological study of religions, we must not neglect the “founding fathers” of sociology. Certainly, their studies are limited by the scope of the possibility of objective knowledge in the nineteenth century, however, one way to better understand contemporary phenomena is to get a dimension of historicity and process with the aid of classics (Stinčkomb, 1999: 262).

In this paper, we will embark on the adventure of classical heritage studies in order to make the difference between theoretical and historical insights useful for contemporary sociology, and those conclusions that are nevertheless a burden of the nineteenth-century social thought limitations. Weber’s analysis of events in Russia at the beginning of the twentieth century is an analysis of the Dual *Otherness*: it is a political analysis of the German enemy, but it is also a cultural and socio-religiological research

¹ Nevertheless, Bauman acknowledges that precisely from one sociological classic (George Simmel) he has learned most about the relationship with foreigners and towards the *Otherness* (Bauman, 2004: 15).

of Orthodoxy with which the German author did not have direct contact. As Max Weber is the classic author who certainly contributed most to the development of sociology of religion as a special discipline, we will reach for his view of the connection between the collectivist basis of Orthodoxy and collectivist secular ideologies in Russia at the beginning of the twentieth century. Certainly, we will adhere to Bauman's advice in the form of avoiding "loading" up-to-date knowledge in the analysis of classical works, yet we will try to critically analyse the scope of Weber's conclusions on the correlation between Orthodox ethics and political events in Russia.

An example of Weber's interpretation of Orthodoxy is especially interesting because he was largely influenced by his rather emotional attitude towards the events in Russia at the beginning of the twentieth century: from the enthusiasm of the overthrow of 1905 to the permanent disappointment that will continue after the October Revolution of 1917 (Radkau, 2009: 241).² Since Max Weber is the author who insisted in his works on a holistic study of social reality (Jaspers, 2015; Roth, 1976), the analysis of the political situation in Russia could not be done without an economic, cultural, ideational, but also religiological dimension, so that this theme is especially inspiring from the point of view of the sociology of religion. Also, the example of Weber's research between the Orthodox ethics of collectivity and the Russian tendency that it does not provide more lasting resistance to the authorities on account of the higher (collective) good is especially interesting if one takes into account his call for separating the sphere of political action from dealing with a value-neutral and objective social science (Weber, 1989). He worked hard to show on his own case how it is possible to distinguish between these two spheres of action (although both were very important to him!), and thus contribute to achieving objectivity in social sciences. It is very important to deal with the case in which Weber may have deviated most from this ideal, which is precisely the case of Russia. As he had been engaged several times in the form of a political actor who had been agitating

² An interesting example is the letter that Max Weber addressed to György Lukács (1885-1971): Weber said that the practical communist revolution is discredited for the future of the entire socialism (Дмитриев, 2017: 87). This case testify about how much Weber was disappointed with in Russia.

for the alliance between the Second Reich and Russia, it is interesting to follow the genesis of relations with Russia from initial enthusiasm to the sharp criticism of the regime after 1905. The explanation for the failed liberalization in this eastern European country is, according to Weber, *also* in the collectivist *ethos* of Orthodoxy. According to Russian sociologists, Weber is almost the only West European author who spoke about the First Revolution not from a tactical point of view, but from a theoretical and sociological point of view (Дмитриев, 2017: 88).

In this paper, we will not focus on the economic aspect, that is, we will not deal with the scope of Weber's thesis on cohabitation between Protestantism and capitalism (i.e. the absence of symbiosis between Orthodoxy and capitalism – for more see: Zabaev, 2015), nor will we deal with presence or absence of Orientalism in Weber's interpretation of events in Russia – for more see: Subotić, 2013; Nojman, 2011); however, we will deal with the connection between the dogmatic ethical basis and the philosophical and political tradition that was dominant in Russia after 1905. We will try to show the extent to which Weber's study is useful as a historical testimony, but also as a methodological guide for contemporary studies. In other words, we engage in Weber's analysis of the Russian and Orthodox *Otherness* without modern preconceived ideas.

Weber's research on revolutions in Russia at the beginning of the twentieth century

Although, after a brief stay in the United States in 1904, Weber was thrilled with the bureaucracy of the state administration and the army in that country, the events that took place in Russia in 1905 completely directed his research attention to that part of the world. The series of protests against the absolutist regime of Emperor Nikolai II (1868-1918), strikes, rebellions against the lost war with Japan (1904-1905) and demands for the liberalization of the political regime and a more adequate political response to the modernization of the country and the introduction of capitalism and industry led Weber to compare these events with events in Germany from 1848 to 1849 (Weber, 2006: 40). "Weber learned the

Russian language in a very short period of time, he regularly subscribed to the Russian press, and his enthusiasm about the events of 1905 was more than obvious. Weber was also interested in the influence of Kant (*Immanuel Kant*) philosophy on Lenin's (*Владимир Ильич Ульянов Ленин*) ideology and was fascinated by the poet of Leo Tolstoy (*Лев Николаевич Толстой*). Weber writes to his wife that he wants to write a book about the Russian classics because he succeeded in "embodying the soul of the Russian people" in his works and to underline the clear distinction between rational cosmic ethics (which is the nucleus of Western Christian schism) and egoist ascetic dogma on one, and irrational acosmic love which constitutes the basic ethical and emotional component of Orthodoxy and Russian culture on the other" (Jovanovic Ajzenhamer, 2018: 164). Weber wrote two articles on the 1905 revolution, the *Bourgeois Democracy in Russia* (*Zur Lage der bürgerlichen Demokratie in Russland*) and the *Russian transition to pseudo-constitutionalism* (*Russlands Übergang zum Scheinkonstitutionalismus*), and in both cases it is noticeable that, after the initial enthusiasm regarding the democratic potential of change in Russia, the authentic liberal Max Weber, was deeply disappointed with the epilogue of revolution (Dmitriev, 2017: 306; Троицкий, 2014: 203; Головин, 2017: 74).

Although German-Russian bilateral relations were getting tougher, Weber initially kept romantic ideas about the compatibility of German and Russian national *ethos*. He spoke of the ideals that led Eastern Prussian class representatives in 1848 to the unification of the German Empire, resembling the ideals for which the Russian people fought in 1905, primarily the proletariat (Weber, 2006: 40). Weber follows Bismarck's (1815-1898) idea of a good co-operation with Russia which is beneficial for Germany (though he did not consider the policy of the *Triple Alliance* to be a good solution for the Second Reich) and therefore makes the above-mentioned parallel between the two "revolutions". The altruistic and collectivist ethical basis of fraternal love in Orthodoxy is only an additional propelling fuel for the light, anti-authoritarian future of Russia, said Weber in 1905. But precisely because of the great passion and hope that he showed in following and studying the events in Russia in the twentieth century, the disappointment with the outcome of the so-called First revolution was great. He

calls the regime in Russia, after 1907, pseudo-democratic, their economy sandy and unsustainable, and changes on the value and philosophical level are only momentary and short-lived (Mommssen, 1997: 11-15).³ However, Weber will remain committed to the idea that the authentic democratic spirit of the Russian people is compatible with German political ethics, but has repeatedly emphasized that with the current Duma there is no negotiation nor cooperation. Joachim Radkau correctly refers to the relationship of Max Weber with Russia as the relationship “between love and hatred” (Radkau, 2009: 241) because he spoke equally passionately of the freedom-loving spirit of the Russian rebels, as well as of the breakdown of liberal ideas in political reality after 1907 (also including here the October Revolution).⁴

Weber’s idea that Russian ethics is determined by collectivism is not his authentic finding; throughout the nineteenth century in France and England, but also in Germany, debates were being held as to whether Russian anti-individualism was good or bad, or whether it was a fertile ground for co-operation or was an insurmountable obstacle. For conservatives such as Joseph de Mestre (1753-1821), Russia is a force that will help Europe to return to its self, its *ancient regime*. De Mestre considered that the Russian people possessed “some innate wisdom in the sense of the absence of the rationality that was envisioned by the enlightenment as a European and world ideal” (Nojman, 2011: 112).⁴ The French philosopher and diplomat called on the Russians to abandon the “poison of individualism and religious reformation” (Nojman, 2011: 112).⁵

³ One of the causes of the collapse of liberal ideas in Russia and the survival of the Czarist regime, Weber, is that the proletariat remained alone, i.e., there was a coalition between the proletariat and the bourgeois intentions that could lead to more radical changes (Dmitriev, 2017: 309).

⁴ Weber dealt with the later events in Russia, mostly from the perspective of German-Russian relations, but did not go into a detailed study of the internal social dynamics in that country. This is true even for the events of 1917. Quite resigned, Weber concluded that Bolshevism is a military dictatorship, like any other, and that it will collapse like all other military dictatorships (Dmitriev, 2017: 326). In this paper we focused on Weber’s engagement with Russia in the period 1905-1907, not only because this period he dealt with much more detail, but also because he tackled religious issues (which is the most important for us).

⁵ However, De Mestre also considered that Russia should be put under the Catholic Church, but even if this fails, he believed that this eastern Euro-

On the other hand, the liberals viewed Russia as a reactionary state, which has been engulfed in collectivism, civil rights violations and the lack of legislation. In his report addressed to the Foreign Minister, Comte de la Moussaye (1715-1778), the French Charge d’Affaires in St. Petersburg, said among other things: “There is an insurmountable obstacle in front of them (*the Russians* – N.J.A.) because no law can exist without civil liberties, and, in short, they all shiver before the sovereign, as those who sit in his councils, as well as those in the military leadership” (Nojman, 2011: 113). Weber is distinguished from his predecessors by the fact that he is a liberal who believes in the Russian potential for democracy, although ultimately, he comes to the same, for him the defeating conclusions, that is, authoritarianism and collectivism are an insurmountable obstacle in cooperation with this Eastern European country. Also, in the pleiad of possible explanations why Russia is so firmly rooted in collectivism (the absence of the middle class, the illiterate peasantry, Imperial power, etc.), Weber particularly emphasizes Orthodox heritage and the influence of the Russian Orthodox Church and thus makes a relationship between religious dogma and social reality, otherwise specific to his sociology.

But, as we have already said, Weber’s analysis of the situation in Russia, during and after the First Revolution, was clearly coloured by a religious component. Weber was interested in the study of Orthodoxy precisely when he began to study Russian history and contemporary events, so it is not wrong to conclude that the Russian variant of Orthodoxy was his first contact with Eastern Christianity and at the same time his prototype. Although during the revolution he spoke with excitement of the “Russian soul” and “brotherly love”, which is the ethical basis for building a Russian, highly collectivistic, ethics that has its own political consequences, later these terms were given a pejorative sign. Here is one (for domestic sociology) a particularly interesting example that illustrates this. When Russia interfered in the situation in the Balkans, Weber explained this with the burst of emotions (based on Orthodox connection). Weber believed that the Orthodox emotional connection between the Serbs and the Russians had clouded rational military

pean country was a corrective of the Western rational decadence (Nojman, 2011: 112).

logic. "In the interest of its survival, Austria had to demand only that Russia be not interested in the area from the Adriatic Sea to the Bulgarian border. Only later, when engaging in Serbia, Russia came into the situation that it could not do it. If you feel motivated by politics to engage in those places where out of political and geographical reasons, it is not certain that your political power could penetrate, then you will easily hurt your reputation by wrong moves; we have experienced this in our policy towards the Bulgarians, and the Russians feel a lot on their skin because of their policies towards Serbia because Russia has politically escaped from its natural sphere, Germany has returned to the Far East, and – what was very unpleasant for Russia – entered the military alliance with Turkey and Bulgaria" (Weber, 2006: 111). Thus, Weber, obviously desperate because Russia turned to Serbia rather than co-operation with Germany, points out the "collectivist ethics of Orthodoxy that dogmatically suggests co-operation beyond rational geopolitical logic" (Jovanović Ajzenhamer, 2018: 165).

When he talked about events in Russia between 1905-1907, but also later, after the October Revolution, Weber (as seen from the examples of Russia and Serbia), analysed the role of Orthodoxy in political events in this eastern European country. We can learn a lot about Weber's interpretation of Orthodoxy precisely from his political analysis, but of course from his sociological texts. But the curiosity is that Orthodoxy is a rare example of religion that he observed in the context of a state and which he analysed from the point of view of symbiosis with secular ideologies while other religions he mainly studied *sui generis*, that is, they are independent of specific states.

Weber was not unfoundedly considering the importance of Orthodoxy for the development of the social situation in Russia. The Russian Orthodox Church in Imperial Russia played an extremely important social and political role, and therefore Orthodoxy is a very important component of the entire research of the social reality of Russia at the turn of the nineteenth century in the twentieth century, and Weber rightly underlined it. In Russia in 1870 there were as many as 70% of Orthodox believers. Catholics (8.9%), Mohammedans, (5.2%), Protestants (3.2%), Judaists (3.2%) and so on. Apart from the fact that the Orthodox believers were the most

represented, it should be noted that in Imperial Russia the Orthodox Church played a particularly important social role because it was practically part of the state apparatus. The Monarchist state provided the church with financial resources and status, while, on the other hand, religious norms played an important role in regulating many aspects of social life (primarily in the domain of education of the population). Also, one should not forget that the church, given that it protected the interests of the emperor, received the land in the form of donations, and thus became one of the largest landowners in imperial Russia. The Church also advocated for the preservation of the serf status of the peasantry and their attachment to the land. The symbiosis between the state leadership and clergy and the poor status of the lower classes who were also exploited by the church would lead to an explosion of dissatisfaction in the twentieth century (Blagojević, 2015: 60-62). Because of this strong influence of the Orthodox Church, its cooperation with the authority and the advocacy of collectivist goals (with the goal of finally obeying the Emperor and the Church), it is not surprising that, based on the Russian example, Weber made conclusions about the primary collectivist character of Orthodoxy (Weber, 1973: 145).

Collective-Oriented and Mystical Orthodoxy: Max Weber on Eastern Christianity

Weber distinguishes three basic religious attitudes toward the earthly world, that is, to the rescue of the hereafter, and they are the following: the flight from the world (Hinduism and Buddhism), adapting to the world (Taoism and Confucianism) and reconciling oneself to this world (Judaism and Christianity) (Weber, 2015: 191). In the first and third cases, the conflict between the two worlds is intensified – the more perfect the hereafter is, the less attractive is the world of man, and therefore salvation is necessary after death. However, while the Hindu concept of karma reduces the ethical contradiction of the two worlds (as the soul circles through a variety of lives), the Christian conception of the original sin is radicalized. But Weber's classification system of the

world's religions also implies a distinction between *religions that are fleeing from the earthly life and religions that are opposed to the earthly world*. The first category includes Western Christianity, Hinduism and Buddhism, while the second group includes Protestantism, Judaism, Islam⁶ and Orthodoxy (Schluchter, 1987: 112). It is particularly interesting to notice the difference between Western Christianity and Protestantism in Weber's theory. Weber believes that in medieval Christianity religion was divided into the asceticism of "virtuosos" (in monasteries) as well as the widespread religiosity of the people (who easily receive the forgiveness of sin, primarily, though not exclusively, by exchanging money for forgiveness). Lutheranism, and especially Calvinism, abolish this division and demand a general asceticism, the abolition of the payment for the forgiveness of sins and the decentralization of the papal chair. The preaching of *predestination* leads such ethical tension to climax. Since believers need belief that they will be "saved", the solution was found in the teaching of "signs" of predestination – it is always a success in the call that a believer in this world deals with and therefore financial gain becomes one of these "signs". Weber's, now famous and well-known, theoretical logic implies that the basic hypothesis is that Calvinism affirms the knowledge of this world, which on the one hand promotes capitalism (success in the turn of capital), but, on the other hand, ^{the} science (which studies the world with the aim of conquering it). In this way, Christianity has given itself an "own goal" because science will gradually create a new monism in the future – the hereafter disappears and remains non-magical (or non-religious) earthly world (Weber, 2011).

But there is another watershed between Protestantism on one side and Judaism, Islam and Orthodoxy on the other. It is a sense of superiority over the world, that is, submersion in the collectivist acceptance of fate and higher goals against the individualist imperative of struggle for one's own well-being (Schluchter, 1987: 112). "The premise of Luther's revolt against the priesthood

⁶ Since Weber was quite contradictory about the positioning of Islam in all of the above categories, Schluchter positioned Islam in its work as a religion that adapts to the world, but also as a religion that opposes the earthly. We consider that there are many more arguments to be classified in another category (for more, see: Jovanovic, 2016a, Jovanovic, 2016b).

and institution of the Church in general was the return of an individual in a position of direct contact with God, without (sometimes even very ethically suspicious and interest-based) mediation of authorized church persons. Thus, in Protestantism, the believer stands alone before the Creator, who is the only entity to whom the believer should be accountable. The purchase of compassion, the forgiveness of sins and the guarantee of salvation are, according to Protestant doctrine, the essential anomalies of Christian ethics. That is why Protestantism insists on individualism and on individual responsibility both on earth and at the place where one leaves after *post mortem*" (Jovanović, 2016b: 454). Contrary to the distinctly individualist *ethos*, which is an important foundation of Protestantism, and which is a link to the cohabitation between Calvinist ascetic Protestantism and modern capitalism, there are religions that are oriented to the well-being of the collectivity. The Jews, according to Weber's opinion, are interconnected by the *ressentiment*, that is, the collective desire for revenge on account of their expulsions and unequal distribution of wealth and power (Weber, 1952), Muslims are tied to the *uma* (the umbrella-like global community of all Muslims) and are obliged to do good deeds to members of the *uma* and Orthodoxy is centred around the concept of fraternal love. Weber argues that Orthodoxy took over the concept of collective love from the early Christian postulates and that it was marked by mysticism (Jovanović, 2016b: 457). Both in Orthodoxy and in Islam, brotherly love is one of the fundamental values of postulates, which is also reflected in the development of "serious charitable ethics" (Weber, 2015: 198),⁷ however, all similarities with these two religions end there. Orthodoxy is coloured by contemplative and mystical, and Islam is, according to Weber's opinion, determined by the violent holy war. According to Weber, Judaism stands out because of its rational orientation towards individuals themselves and their everyday ethics, yet the collective *ressenti-*

⁷ One of the examples that Weber illustrates the significance of collectivism in Islam and "old Christianity" is the importance of giving alms and helping other believers of the same faith. In Islam this is even canonized through the obligatory annual tax, that is, *zekat*, while in Orthodox churches it is an optional but desirable form of helping members of the same religion (Weber, 2015: 197).

ment is what Judaism, however, places in the religions of collectivity (Veber, 1976: 417-419).

Thus, in Orthodoxy, Weber identified the mystical elements that were part of early Christianity, and which disappeared in the development of the Western variant of Christianity. This sociological classic insists on the difference between cosmic rational ethics and acosmic irrational love, which lies at the root of the difference between the egoist ascetic dogma (which reaches its climax in Protestantism) and collectivist, fraternal emotion in Orthodoxy. In fact, Weber only repeats the division of Ernst Troeltsch (1865-1923) into absolute universalism and absolute individualism. But, unlike Troeltsch, who sees this dichotomy in the Gospel case,⁸ Weber extends his logic and applies it to the explanation of the ethics of the entire Christianity and the history of division in Christianity (Polke, 2018: 74). Weber believes that Orthodoxy conserved and preserved certain elements of old Christianity, such as the broad pantheon of saints (Turner, 1998: 61), but also the original Christian ideal of fraternal love and the highness of collectivity⁹ that has its consequences both at the social and political level (this we can see in the case of his analysis of Russia). It is interesting that at the very moment when Tolstoy died, at the other end of Europe (in Germany), after Trelch's presentation about Christianity (*Das stoisch-christliche Naturrecht*) at the first meeting of the German sociological association, Max Weber, for the first time in the public, on the example of Tolstoy, presented his conception of "acosmic love" (Троицкий, 2014: 200-201).

Weber identifies the powerful influence of Orthodoxy as one of the more important "breaks" for the development of liberal ideology in Russia because the Orthodox ethic of fraternity implies that there is no high evaluation of the cult of the individual. On the other hand, in rejecting the "ethics of success" in the field of politics and obedience to what is imposed from below, he also sees a synthesis between Orthodoxy and the political and social factual situation in Russia after 1905. "If what is considered to be a positive duty is done" then, since no other value can be an ethical value, the

⁸ It is about the so-called. "The double sociological character of the Gospel" (Hajns, 2011: 71).

⁹ Weber often calls Orthodoxy "old Christianity".

same biblical sentence takes its effect and is deeply etched not only in the soul of Tolstoy, but also in the entire Russian people: “Do not resist the evil” (Weber, 2006: 44).

Weber argues that Orthodoxy has not far advanced in the process of *rationalizing of religious ethics* (unlike other Christian denominations, above all, Protestantism, but also Catholicism to a lesser extent). Although one of the key notions for Weber’s sociology (rationalization) is not precisely defined, in the sphere of religion, one of the basic indicators of the degree of rationalization of certain religious ethics is the level of lack of magic elements in a religious dogma. Without going into all the details of an extremely complex topic (whether there is a single direction of rationalization at all or more varieties, how the degree of rationalization permeated different religious ethics, what is the relationship between religion and other social domains with regard to rationalization, etc.), we will only underline that Weber believed that Orthodoxy was a religion that did not much advance in the process of rationalization (Jovanovic, 2016: 93; Kalberg, 1980: 1145; Троицкий, 2016: 21-22). This conclusion is a logical consequence of his interpretation of Orthodoxy as a mystical religion. “There lives in the Orthodox Church a specific mysticism based on the East’s unforgettable belief that brotherly love and charity, those special human relationships which the great salvation religions have transfigured (and which seem so pallid among us), that these relationships form a way not only to some social effects that are entirely incidental, but to a knowledge of the meaning of the world, to a mystical relationship to God” (Weber, 1973: 144-145). As we have already said, Weber, as a rule, when speaking of Orthodoxy relates to the works of Leo Tolstoy (1828-1910) and Fyodor Dostoevsky (1821-1881), thus creating a unique whole between Orthodoxy and the “soul of the Russian people” depicted by Russian literary classics in their works. “The Russian soul”, according to Weber, is particularly religious, enthusiastic, romantic prone, but also ready to surrender to fate without a fight (Weber, 1973: 144-145; Троицкий, 2014: 205-206).

It is interesting that Russian authors (Zabaev, 2015, Dmitriev, 2017; Головин, 2017: 73) criticize Weber for a simplified interpretation of the “soul of the Russian people” through the analysis of Russian literature of the nineteenth century. In the opinion of

Ivan Zabaev, the literary work of Russian writers and philosophers at that time was painted with a romantic view of the nation and religion and cannot be representative of the views, values and practices of the entire Russian *populus*. Zabaev considers that, at the very least, it is too hasty and simplified to attribute the failure of liberalization of the country to Russia's orientation towards collectivity induced by Orthodox ethics. Also, drawing such conclusions Weber influenced many important works such as the research of the influential sociologist Andreas Buss (Buss, 1989a, 1989b) who explained by Weber's logic not only the development of Orthodoxy in Russia, but doing so he also explicated the lack of entrepreneurial spirit in that country, as well as the authoritarian tendencies in the domain of government (Zabaev, 2015: 151). This kind of criticism is also presented by the authors who deal with the reconstruction of Weber's thoughts on Islam, reproaching him, first, for the reductionism in the analysis of all oriental, that is, *Other* religions (Orthodoxy, Islam, Buddhism, Hinduism, etc.) (Turner, 1998; Farris, 2013). We can add to these criticisms the lack of dealing with Orthodoxy in other countries in which the Orthodox population make up the majority of the population. Although, as we have seen, Weber accentuates the Orthodox connection between Serbia and Russia, he does not enter into the details of the development of Orthodoxy in Serbia, but also in Greece and other major Orthodox countries.

Discussion

Weber's conclusion that Russia is a country with the ideal of collectivity fits into the general trend of the nineteenth-century European perspective of the political and social situation in that country. Between the conservatives and the liberals "the spears were breaking" as to whether Russian collectivist *ethos* benefits Europe or is, on the contrary, an obstacle to co-operation. Weber was liberal, but also a German nationalist who in the "Russian soul" recognized the German liberal sentiment from the period 1848-1849. When he saw that the regime had become "ostensible constitutionalism" after the overthrow (Weber, 2006: 68), the rhetoric

about Russia became harsh and extremely critical, yet he retained the idea that the Russian people were authentically inclined to democracy (about which, in his opinion, testify the works of literary Russian classics), but that the perverted authorities managed to keep leverage of power in their hands and to lead Russia into a downfall of authoritarianism. Thus, Weber's initial hypothesis that the "Russian soul" was determined by collectivism was not original.

Even the conclusion that Orthodoxy had influenced a high degree of authoritarianism in Russia and the acceptance of a situation such as is, and conciliation with a fate without potential for insurrection is not overly innovative, although Weber systematically more than most other authors rounded this idea. But what is certainly different and what makes Weber a classic sociologist of great renown is his ability to circle a narrative about a culture, country or nation with a holistic puzzle from multiple social parts. While other authors explain the situation in Russia primarily with one cause, Weber is one of the few thinkers who approaches his subject of study with the demand of holism, processuality and pluricausality. In his study of Russia, Weber did not omit either the class dimension, the type of power, or the geopolitical position and history, but he did not ignore either the cultural or the religious dimension. In this paper we have emphasized the last of the above, because we consider that this is one of the most important determinants in explaining Weber's interpretation of the situation in Russia, but this does not mean that we are exhausting all aspects to be studied, on the contrary! Certainly, Weber's conclusions about Russia are at many levels controversial,¹⁰ but his approach is a good showcase for the sociologist in terms how to access their subject of study – society in its totality.

So, Weber's study of Russia should be seen on several levels. His texts are another testimony of how Russian *Otherness* was

¹⁰ Weber uses the concepts commonly used in social sciences such as the "spirit of the people", "souls of the people", the ethics of the whole communities, etc. So, therefore, he is most often accused of reductionism and "methodological European centricism" (Hajns, 2011: 148). But, you should be cautious when assessing the degree of European centricism in the work of nineteenth-century thinkers, because it is necessary to bear in mind the general context and academic tradition within which individuals create.

treated and fitted into the construction of a European identity and therefore we can certainly not judge it as a study that is relevant for the contemporary study of Russia, but we must bear in mind that we want to study the history of constructing a European identity in relation to the Russian antipode.¹¹ In the context of the study of the construction of modern nations and identities that could not pass without *Kulturkämpfe*, without cultural struggles (Bauman, 2017: 42) it is very important to pay attention to the work and activism of Max Weber. Weber's research is the result of one's own time, and certainly we should not think of it, as Bauman reminds us, within the scope of contemporary social thought, but, if we want to deal with this phenomenon, Weber's study is indispensable because it provides a serious historical perspective and insights into how European intellectuals and political activists perceived the Russian *Otherness*. On the other hand, the Weber's study of Russia is a good example of how the subject of study is approached and how it is researched, and its principle can be to great extent beneficial to contemporary sociologists. No matter that Weber on the case of Russia failed to fully apply the ideal of value neutrality, because he passionately sought for an alliance between Germany and Russia (unlike some other cases when in this ideal he was much closer), many of his insights, and above all, dedication and thoroughness in studying the "Russian case" are still the "gold standard" in sociological research today. So, Weber's study of Russia is not utilitarian only as a historical testament, but it has its own theoretical and methodological benefits, both for the sociology of politics, and for the sociology of religion.

Let's for a moment get back to the beginning of the debate from the beginning of the work on whether and how we can read and use the classics today: we believe that the key is to separate the analytical levels in which we treat sociological heritage. By splitting the classics into a number of analytical levels, we will avoid Bauman's determination to "judge" the nineteenth-century thinkers as if they were contemporary, but we would also succeed in applying Stinchcombe's advice that classics are not only for dust covered bookcases and only serve as part of academic curric-

¹¹ This principle was also applied in Jovanović, Mentus, 2017.

ula at Universities, but can also be an inspiration for contemporary research: both at the historical, but also theoretical and methodological levels. Weber's study of Russia and Orthodoxy served just as an example for the promoting the idea of the necessity of analytical differentiation in the approach to the "founding fathers" of sociology.

Literature

- Bauman, Zigmund. (2004). *Identity: Conversations with Benedetto Vecchi*. Cambridge: Polity.
- Bauman, Zigmund. (2017). Evropa stranaca. u: (ur.). Marinković, Dušan; Ristić, Dušan. *Stranac u humanističkom nasleđu*. Novi Sad: Mediterran Publishing: 38-54.
- Buss A. (1989a) The Economic Ethics of Russian-Orthodox Christianity: Part I. *International Sociology*. Vol. 4. No. 3: 235-258.
- Buss A. (1989b). The Economic Ethics of Russian-Orthodox Christianity: Part II. Russian Old Believers and Sects. *International Sociology*. Vol. 4. No. 4: 447-472.
- Dmitriev, Timofey. (2017). Max Weber and Peter Struve on the Russian Revolution. *Studies in East European Thought*. Vol 69. No. 4: 305-328.
- Farris, Sarah. (2013). *Max Weber's Theory of Personality: Individuation, Politics and Orientalism in the Sociology of Religion*. Leiden, Boston: Brill.
- Kalberg, Stephen. (1980). Max Weber's Types of Rationality: Cornerstones for the Analysis of Rationalization Processes in History. *The American Journal of Sociology*. Vol. 85. No. 5: 1145-1179.
- Mommsen, Wolfgang. (1997). Max Weber and the Regeneration of Russia, *The Journal of Modern History*, Vol. 1. No. 69: 364-383.
- Polke, Christian. (2018). Troeltsch's Personalism. in: (eds). Adair-Toteff Christopher. *The Anthem Companion to Ernst Troeltsch* London, New York: Anthem Press: 71-82.
- Radkau, Joachim. (2009). *Max Weber: A Biography*. Cambridge: Polity, 2009.
- Roth, Guertler. (1976). History and sociology in the work of Max Weber. *British Journal of Sociology*. Vol. 27. No. 3: 306-318.
- Schluchter, Wolfgang. (1987). Weber's Sociology of Rationalism and Typology of Religious Rejections of the World. in: (eds). Lash, Scott; Whimster, Sam. *Max Weber, Rationality and Modernity*. London and New York: Routledge: 92-118.
- Turner, Bryan. (1998). *Max Weber Classic Monographs. Volume VII: Weber and Islam*. London and New York: Routledge.

- Weber, Max. (1952). *Ancient Judaism*. Glencoe Illinois: The Free Press.
- Weber Max. (1973) Max Weber on Church, Sect, and Mysticism (eds. Nelson B.). *Sociological Analysis*. Vol. 34. No 2: 140-149.
- Zabaeв, Ivan. (2015). The Economic Ethics of Contemporary Russian Orthodox Christianity: A Weberian Perspective. *Journal of Economic Sociology*. Vol. 16. No 4: 148-168.
- Николай, Александрович Головин. (2017). „Макс Вебер: 'Все мои симпатии принадлежат русскому освободительному движению': статьи, письма и очерки классика социологии о революциях, войне и демократии”. *Журнал социологии и социальной антропологии*. Вол. 20. Но. 4: 70-88.
- Дмитриев, Тимофей. (2017). „Русская революция как опытное опровержение социализма: версия Макса Вебера”. *Russian Sociological Review*. Vol. 16. No. 3: 87-110.
- Троицкий, Константин Евгеньевич. (2014). „Макс Вебер как Анти-Толстой”. *Этическая мысль*. Выпуск 14. Москва: Российская Академия Наук Институт философии.
- Троицкий, Константин Евгеньевич. (2016). Этические идеи Макса Вебера. Москва: Российская Академия Наук Институт философии.
- Blagojević, Mirko. (2015). *Vitalnost religije u (de)sekularizovanom društvu*. Beograd: Institut društvenih nauka.
- Hajns, Folker. (2011). *Uvod u Maksa Vebera*. Beograd: Biblioteka XX vek.
- Jaspers, Karl. (2015). *Maks Veber*. Beograd: Dosije studio, Biblioteka Parega.
- Jovanović, Nataša. (2016a). Nastanak islama kroz teorijsku prizmu Maksa Vebera (uloга просторног контекста и друштвених актера и слојева у процесу дефинисања и експанзије исламске религије). *Sociološki pregled*. Vol. L. No. 1: 91-117.
- Jovanović, Nataša. (2016b). Veberovo shvatanje koncepta individualizma kao osnov komparativne analize religijskih sistema: primer protestantizma i islama. *Srpska politička misao*. Vol. 54. God. 23. Br. 4: 451-471.
- Jovanović, Nataša; Mentus, Vladimir. (2017). Classical roots of contemporary understanding of Islam as religion of warriors – the implications of Weber’s interpretation of Islamic dogma. in: (eds.). Blagojević, Mirko; Matić, Zlatko. *Religion in Contemporary Society*. Belgrade: Institute of Social Sciences, Belgrade Department of Education and Culture, Serbian Orthodox Diocese of Branicevo, Pozarevac: 213-228.
- Jovanović Ajzenhamer, Nataša. (2018). Pogled na spoljnopolitičku poziciju Nemačkog carstva iz ugla istorije socioloških teorija: Maks Veber o međunarodnim odnosima. *Srpska politička misao*. Vol. 60. God. 25: 155-176.
- Nojman, Iver. (2011). *Upotrebe Drugog – "Istok" u formiranju evropskog identiteta*. Beograd: Službeni glasnik i Beogradski centar za bezbednosnu politiku.

- Stinčkomb, Artur. (1999). Treba li sociolozi da zaborave svoje majke i očeve? u: (prir). Mimica, Aljoša. *Tekst i kontekst: ogledi o istoriji sociologije*. Beograd: Zavod za udžbenike i nastavna sredstva.
- Subotić, Milan. (2013). Edvard Said i "ruski orijentalizam". *Treći program*. Br. 158: 115-139.
- Weber, Max. (1989). *Metodologija društvenih nauka*. Zagreb: Globus.
- Veber, Maks. (1976). *Privreda i društvo, knj. 1–2*. Beograd: Prosveta.
- Veber, Maks. (2006). *Politički spisi*. Beograd: Filip Višnjić i Službeni glasnik.
- Veber, Maks. (2011). *Protestantska etika i duh kapitalizma*. Novi Sad: Mediterran Publishing.
- Veber, Maks. (2015). *Sociologija religije – tipovi religijskih zajednica*. Novi Sad: Mediterran Publishing.

ОЛЬГА СМОЛИНА
Восточноукраинский национальный университет
имени Владимира Даля

Культурологические проблемы религиозной жизни украинских земель в X – XVII вв.

Аннотация

В теме религиозной жизни украинских земель X-XVII вв., несмотря на значительную степень ее изученности, продолжают возникать дискуссионные вопросы. Их рассмотрение с позиций культурологии позволяет обратить внимание на неосвещенные ранее аспекты, выявить лакуны. В свете современных сложных процессов смены цивилизационных и аксиологических ориентиров в украинской культуре данные темы не потеряли своей научной актуальности. Так, например, дискуссионным есть вопрос об экологичности славянского язычества, гармоничных отношениях с природой той культуры, которую оно породило, и просчетах христианства в этой области. Обоснование ведущей роли монашества в православии позволяет отвести от последнего обвинения в провоцировании современных экологических проблем. Не менее дискуссионным является вопрос о том варианте христианства, который был принят Русью и о специфике киеворусского православия. Признание отличия базовых образов Христа в византийском и славянском восприятии (Г.П. Федотов) позволяет выявить особенности киеворусского православия.

В целом же определяющими для культуры региона данного периода являлся комплекс бинарных оппозиций, наиболее значимыми из которых были: земное – небесное, национальное – религиозное, традиционное – инновационное, свое – чужое, монастырь – мир. Нужно отметить, что их разрешение искалось и находилось в плоскости компромисса, смягчения напряженности противоречия, доказательством чему выступает, например, отождествление веры и нации, попытка объединения церквей, неактуальность противоречия между любовью к Богу и любовью к людям и ряд других.

Ключевые слова: религиозная культура, киеворусское православие, украинские земли в X – XVII вв., бинарные оппозиции, украинская культура.

Основные дискуссионные вопросы культурно-религиозной жизни Киевской Руси.

■ На период существования Киевской Руси в украинской истории приходится значительные изменения в религиозной жизни: традиционная этническая религия (язычество) сменяется одной из мировых религий – христианством. Введение христианства в Киевской Руси – сложная научная тема, все еще вызывающая дискуссии. Данная тема актуальна в связи с процессами возрождения украинской культуры. Рассмотрим эту тему через ряд наиболее значимых культурологических вопросов.

Традиционно акт крещения Руси, опираясь на летописное свидетельство «Повести временных лет», связывают с деятельностью князя Владимира Святославича (внука княгини Ольги) и относят к 988 г. Однако необходимо иметь в виду, что христианизация Руси не была одномоментным явлением. Это был процесс, в котором можно выделить несколько этапов. Первым из них является так называемое «Аскольдово крещение» в 60-х годах IX в. В данном случае речь идет о принятии христианства киевским князем Аскольдом во время или сразу после одного из его походов на Византию, а также, предположительно, частью его дружины, купцов и, возможно, других представителей общества того времени. Принятие христианства главой и элитой государства позволило и всю Русь с этих пор считать официально (или формально) христианским государством, чему имеются подтверждения в ряде иностранных исторических документов (энциклика константинопольского патриарха Фотия, произведения византийского императора Константина Багрянородного, ряд арабских источников). Также есть летописные свидетельства о наличии в Киеве христианских храмов до 988 г. – св. Ильи, св. Николая.

Второй этап – крещение киевской княгини Ольги в середине X в., что, непременно, стимулировало миссионерскую деятельность христианского духовенства и увеличивало число сторонников новой религии.

Третий этап – личное крещение князя Владимира в 988 г. и крещение киевлян в водах Днепра по его распоряжению. Интересно, что данный значительный факт не упоминается в

современных ему иностранных источниках. Причиной тому, по-видимому, было сложившееся восприятие Руси как государства, сделавшего выбор в пользу христианства со времен князя Аскольда.

В реальности же после двух первых этапов христианизации новая религия не смогла должным образом закрепиться на киеворусских землях в силу ряда причин: малочисленности местных христиан, сильных позициях языческого жречества (волхвов), инертности основной массы народа и др. В связи с этим потребовались решительные действия князя Владимира.

Следующий дискуссионный вопрос темы: какой именно вариант христианства был введен в Киевской Руси? Здесь имеют место следующие варианты ответов: а) византийский (восточно-христианский, т.е. православие по византийскому образцу); б) смешанный (наличие разных источников, из которых Русь черпала христианские идеи; в) кирилло-мефодиевский. Так, например, известно, что княгиня Ольга в 959 г. обращалась к германскому императору Оттону I (т.е. представителю западной ветви христианства, католицизма) с просьбой прислать епископа и священников. А. Колодный в качестве основного аргумента для сомнений в византийском образце киевского православия видит сам обряд крещения киевлян, как он описан в летописи: коллективно, одномоментно, не в храме, замечая, что в данном виде он не согласовывался с уже тщательно разработанной в христианском мире и принятой к X в. практикой (Колодный, Яроцкий, 1999). А.Г. Кузьмин пишет: «в X – XI вв. в Киевской Руси сосуществовали разные христианские общины, так или иначе соперничавшие между собой. Иначе говоря, раннее древнерусское христианство не было однородным и имело разные истоки своего формирования» (Кузьмин, 2004).

Учитывая эти и другие особенности, а также факт участия в христианизации славян братьев-миссионеров из греческого города Фессалоники (Солунь) Кирилла Философа (в монашестве Константин, ок. 827 – 869) и Мефодия (ок. 815 – 885), ряд ученых (А. Кузьмин, А. Колодный, С. Перевезенцев) считают, что ведущей на Руси была кирилло-мефодиевская традиция в христианстве. «Кирилл и Мефодий, учитывая особенности славянского

мировосприятия и наличие в Великой Моравии (куда они были направлены константинопольским патриархом для миссионерской деятельности и по приглашению местного князя – О.С.) ранних христианских общин, разработали вариант христианского учения, позднее названный кирилло-мефодиевской традицией. Кирилло-мефодиевская традиция – это особое течение в христианстве, которое учитывает своеобразие славянского мировоззрения и совмещает в себе черты различных христианских учений» (Кузьмин, 2004).

Характерными чертами этой традиции являются следующие:

- ориентация на раннее единое христианство как идеальную форму христианской церкви и веры вообще (будущий раскол христианства, официально произошедший в 1054 г. уже был ощутим в IX и X вв.);
- признание важного значения идей единства церквей, равенства всех народов и веротерпимости;
- в разработанных для славян церковном лексиконе и правилах богослужения были совмещены черты разных христианских церквей – восточной, западной, ирландской, арианской и др., но базу составляло византийское православие;
- общей чертой православного учения в кирилло-мефодиевской традиции является его светлый и оптимистичный характер, соответствующий коренному руслу славянско-го мировосприятия.

Что же касается преобладания прямых западных или восточных влияний на Русь, то, согласно различным летописным источникам, и Аскольд, и Ольга, и Владимир были связаны с византийской, а не с римской традицией.

Каковы же причины того, что именно христианство после неоднократных его введений и последующих возвратов к язычеству распространилось в Киевской Руси? К тому же оно было введено по образцу, который вписывается в контекст византийской традиции. Среди важнейших причин можно назвать следующие:

политические:

- возможность на основе единой веры объединения государства, состоящего из разрозненных племенных образований;
- модель единобожия способствовала укреплению княжеской власти;
- возможность более тесных, в том числе и династических связей с влиятельными христианскими государствами того времени;
- создание национальной и относительно самостоятельной церкви (согласно восточно-христианской ее модели, не подчиненной римскому единовластию);

экономические:

- южный вектор цивилизационной ориентации Руси, который постепенно стал доминирующим (античные города в Крыму, торговый путь «из варяг в греки», значимость и влияние Византии на международной арене, привлекательность торгово-экономических связей с ней);
- утверждение феодального сословно-имущественного неравенства;

социально-культурные:

- вхождение в мировой культурный контекст;
- получение вероучения и богослужения на родном языке;
- укрепление семьи, повышение уровня общественной морали.

Еще одним дискуссионным моментом в теме введения христианства в Киевской Руси является вопрос о потерях и приобретениях государства, общества, культуры в результате смены веры. В частности, высказывается мнение, что христианизация прекратила существование высокой языческой культуры, имевшей потенциал развития. Действительно, киеворусская этническая религия к X в. еще не сложилась в детализированную и законченную систему и, возможно, имела перспективы дальнейшего развития. Но таких перспектив не имело киеворусское государство, оставаясь оно языческим. Ведущие европейские государства того времени уже были христианизированы, общение с язычниками на равных при-

знавалось, в соответствии с их идеологией, невозможным. Таким образом Русь, не приняв христианство, оказалась бы на обочине европейской политической истории. Что касается язычества, то оно, несмотря на борьбу Церкви с ним, продолжало существовать, проникая в христианство, влияя на него в системе народных верований, обрядов, специфически окрашивая киеворусский вариант православия. Это явление получило название двоеверия.

Также в данном контексте дискутируется вопрос об экологичности язычества, его гармоничных отношениях с природой и просчетах христианства в этой области. Обвинения в адрес христианства, в целом, заключаются в следующем:

- объявив Новый Завет следующей ступенью Откровения по сравнению с Ветхим Заветом, христианство породило идею прогресса, то есть, погони за новинками и усовершенствованиями, в процессе чего эксплуатируется природа;
- христианство слишком антропоцентрично, отрицает самоценность природы, оставляя ей лишь роль пространства для оттачивания человеческих моральных качеств;
- отвергнув анимизм, христианство объявило природу неодушевленной, тем самым способствовало ее изучению, развитию естественных наук, и, в результате, эксплуатации природы, появлению экологических проблем.

Вместе с тем нужно отметить, что один из первых критиков христианства в этом отношении, Л. Уайт, обвинял, преимущественно, западное, а не восточное христианство: «Греки верили, что грех – это слепота разума и что спасение следует искать во внутреннем просвещении и в ортодоксии, то есть в сфере чистого мышления. Латиняне иначе решали вопрос – они понимали, что грех – это нравственное зло, поэтому спасение искали в правильном поведении. Восточная теология была интеллектуалистична, западная – волюнтаристична. Греческий святой созерцал, западный действовал. Втягивание христианства в покорение природы должно было легче проявиться в западной атмосфере» (Уайт, 1990, с. 197).

Представляется вероятным, что одной из причин этих отличий является решающее влияние монашества на православную догматику и обрядовость. Сфера коренного интереса православия – обожение человека и путь его достижения. На этом многоступенчатом духовном пути вопросы природоохраны и природопользования органично входят как пространство приложения совершенствующихся личностных качеств человека. Но самоцелью эти вопросы никогда не станут, иначе православие потеряет свою специфику. Духовное совершенствование человека понимается здесь как условие выживания (т. е. спасения). Природа в православии является своеобразным «неодушевленным ближним». Если христианская культура в ее западноевропейском варианте определенным образом повлияла на возникновение современных экологических проблем, то эта критика никак не может быть отнесена к культуре православного монашества. Таким образом, православие в силу решающей роли в его догматике и обрядовой практике культуры православного монашества не может рассматриваться как фактор, «соучаствующий» в появлении современных экологических проблем.

Принятие Киевской Русью христианства стало стимулом мощных изменений в социально-политической, культурно-эстетической жизни киеворусского государства и в мировоззрении его граждан. Так, благодаря православию произошло смещение акцентов в восприятии человека с внешнего на внутренний, утвердилась идея равенства всех людей перед Богом. В рамках нового вероучения решительно осуждалось убийство, жестокое отношение к слабым, рабам и бедным, запрещалось многоженство, повышался статус женщины в обществе. Благодаря наличию таинства исповеди в сознание человека Киевской Руси внедрялось требование самоанализа, рефлексии.

Православие стало надежной опорой для создания централизованного государства, утверждения единовластия киевского князя. Принятие христианства способствовало возрастанию международного авторитета Руси, превращению ее в полноценный субъект международного права. При этом Русь не попала в политическую зависимость от Византии.

В силу того, что Книга, Слово написанное и произнесенное, являются важной составляющей христианского вероуче-

ния, на Руси стало распространяться образование. Школы различного уровня создаются при приходских церквях, архиерейских соборах, монастырях. Представителями образованной прослойки общества и учителями были, прежде всего, духовные лица. Посредством привозимых переводных книг начинается процесс усвоения Русью цивилизационных достижений античности (преломленных через христианское восприятие) и средневековья. Это стимулирует развитие собственной древнерусской литературы. Благодаря интенсивному храмовому и монастырскому строительству развиваются новые для Руси виды и жанры искусства: архитектура, живопись (в виде фрески, мозаики, иконописи), ряд видов декоративно-прикладного искусства – лицевое шитье, роспись, эмаль, скань, чернь, зернь, филигрань и др.

Таким образом, введение христианства в Киевской Руси было, безусловно, положительным и прогрессивным явлением. Тем не менее, православие на Руси, по сравнению с византийским, имело ряд особенностей. Например, в византийской традиции был укоренен образ Христа-Вседержителя, Небесного Царя и Судьи, а в православии киевского периода – образ униженного или «кенотического» Христа (от греч. «кенозис» – умаление, уничтожение, упрощение, добровольное само-понижение в социальном статусе, бедность, отсутствие дерзости и гордости). Это различие «базовых» образов Христа привело к дальнейшим изменениям в восприятии, в «философии» украинского православия. В византийском типе милосердие ограничивалось милостыней, а в «кенотическом» христианстве к милосердию присоединяется сомоуничтожение. Смирение византийского типа основывалось на строгом соблюдении, и тем самым утверждении, иерархического соподчинения. В кенотическом типе монах, священник смиряет себя не только перед вышестоящими, но и перед низшими чинами общества. Однако при этом он оставляет за собой право (и использует его на практике) быть требовательным, суровым к высшим членам общества, обращаться к ним с властной пророческой силой, призывая к справедливости (например, игумен Киево-Печерского монастыря Феодосий). Следовательно, кенотический тип восприятия христианства разрушает иерархию.

Для византийского типа основной послушания церкви является страх, а кенотический тип послушания питается кротостью, милосердием и воспринимается как взаимная обязанность, уступчивость. В византийском подходе мотивом покаяния был, опять-таки, страх, а в древнерусском – стремление к совершенству по образу Христа (Федотов, 2001, с. 349-350).

В целом можно выделить следующие отличительные черты киеворусского варианта православия домонгольского периода:

- наличие двоеверия (совмещение и местами глубокое взаимное проникновение православия и язычества);
- кенотичность;
- напряженность духовной жизни не между плотью и духом, а между двумя состояниями плоти – падшей и преобразенной;
- редкость явлений мистицизма и созерцательности;
- неактуальность противоречия между любовью к Богу и любовью к людям;
- светлый характер эсхатологических ожиданий (не ожидание Страшного Суда, но чаяние вечной жизни);
- самостоятельная, непосредственная, творческая интерпретация Евангелия;
- равнодушие к почитанию святых дев, исключительный культ священного или божественного Материнства;
- признание возможности не только монашеского, но и мирского пути к спасению (Смолина, 2014).

Проблемы культурно-религиозной жизни Украины XIV – XVII вв.

Исторические события в Киевской Руси XII – XIII вв. оказали значительное влияние на ее религиозную жизнь. После нашествия Батюга и падения Киева в 1240 г. центр государственной жизни переместился в Галицко-Волынское княжество, которое на протяжении еще 100 лет поддерживало традиции Киевской Руси, в том числе и в религиозной сфере. Однако кафедра ми-

трополита Киевского находилась не в Галиции, а севернее: в 1299 г. из соображений безопасности митрополит Киевский и всея Руси переехал во Владимир-на-Клязьме, а его преемник в 1325 г. – в Москву.

После вхождения Галицко-Волынского княжества в состав Великого княжества Литовского православие продолжало оставаться государственной религией. Литовцы, будучи язычниками, воспринимали православие, так сказать, как более высокую ступень религиозного развития, относились с уважением и сами зачастую крестились. Ситуация начинает существенно меняться после заключения Кревской унии в 1385 г. Династический брак литовского князя Ягайла и польской королевы Ядвиги привел к интенсивному распространению католицизма на землях Литвы и Руси, как ее части. По решению Рима на восточных землях основываются многочисленные доминиканские, францисканские монастыри, сюда отправляются католические епископы, создаются соответствующие приходы. Наиболее обеспеченные слои литовского общества, желая чувствовать себя равными с такими же представителями Польши, переходят в католицизм. Фактически это была прозелитическая деятельность католического Рима на изначально (или уже) православной территории.

В 1413 г. был принят так называемый Городельский акт, фактически положивший начало расколу и взаимным претензиям между католиками и православными на данной территории. Согласно документу, равные с поляками права имели лишь те жители литовского государства, которые приняли католицизм, а не схизматики (так католики называли православных, «схизма» от греч. – раскол) и не язычники. Однако позже неоднократно, в 1433, 1434, 1443, 1447 гг., под влиянием гражданского недовольства, угрозы раскола общества, сложной внешнеполитической ситуации и пр. это положение было заменено утверждением о равных правах католиков и православных. Вместе с тем, это были в большей степени декларации, а на уровне практически-государственном и социально-бытовом православные не получили равных прав с теми, кто принял католицизм.

Дополнительные различия в порядок отправления религиозных обрядов католиков и православных были внесены с введением в 1582 г. папой Григорием XIII нового календаря, получившего

название Григорианского. Это привело к сдвигу на 13 дней вперед дат празднования церковных праздников по сравнению с прежним, Юлианским календарем. Последствиями такого нововведения были, во-первых, еще большие, не только догматико-теоретические, но и обрядово-практические отличия между католиками и православными; во-вторых, насильственные действия администрации по переходу на новый календарь, дискриминация православных верующих; в-третьих, возмущение православной общественности. Это вынудило польского короля Стефана Батория (годы правления 1575-1586) издать ряд грамот (1584-1586) с заверениями об отсутствии необходимости для православной церкви переходить на новый календарь (Крижанівській, Плохій, 1994).

В 1569 г. состоялась Люблинская уния, объединение Польского и Литовского княжеств (включая принадлежащие ему земли бывшей Киевской Руси) в государство Речь Посполитую. Объединение подразумевало наличие с этих пор одного короля, единого органа управления – сейма и сената и, по умолчанию, единую религию. И хотя в объединительном документе снова были даны заверения о даровании религиозных свобод православному населению, все же последующие исторические события привели к забвению властями этого обещания. Следует заметить, что сама православная церковь в этот период находилась в состоянии кризиса, к которому привел ряд объективных причин. Среди наиболее значимых нужно назвать следующие:

- заключение в 1439 г. между Константинопольским патриархом и папой Римским так называемой Флорентийской унии – соглашения об объединении православной и католической церкви с большими догматическими и статусными уступками со стороны православия. Соглашение не нашло поддержки у глав поместных православных церквей и населения, но тем не менее, провоцировало раскол в рядах православных;
- захват и разрушение Константинополя – столицы православного мира – турецкими войсками в 1453 г., а также последующие завоевания ими таких православных государств как Сербия, Болгария, Греция, сильно ослабили позиции православия как ветви христианства;

- двойственность положения главы православной церкви митрополита Киевского и всея Руси на киеворусских землях: перенос его резиденции из Киева в Московское княжество состоялся еще в к. XIII века, а территория его правления (собственно митрополия) находилась при этом в другом государстве – Великом княжестве Литовском;
- разделение папой Пием II Киевской митрополии на Киевскую и Московскую в 1458 г., что в условиях падения Константинополя и других православных государств, отсутствия политической власти у Киева, способствовало обращению Киевской митрополии к католическим религиозно-политическим влияниям;
- практика дарения князем высших церковных должностей за деньги или особые перед собой заслуги людям, не имевшим отношения не только к монашеству, но и к церкви. В результате православными епархиями, монастырями и приходами зачастую управляли люди, жизненный интерес которых лежал не в духовно-богословской, а в чисто меркантильной сфере, что приводило к деградации церковной жизни, снижению авторитета православной церкви;
- активизация прозелитической политики ватиканского престола на восточных землях;
- привлекательность католицизма с его социальными и статусными возможностями приводила к уходу из православия наиболее обеспеченных слоев украинского общества того времени;
- отсутствие у православных необходимых и соответствующих времени образовательных и просветительских учреждений на фоне широкой образовательной деятельности католических орденов – иезуитов, бернардинцев и др.

Эти и ряд других факторов явились причинами следующего важнейшего события в религиозной жизни наших земель тех лет – решения иерархов Киевской православной митрополии епископа Владимирско-Волынского Ипатия Потия, епископа Луцко-

го Кирилла Терлецкого, а также самого митрополита Киевского Михаила Рогозы об объединении с римо-католической церковью. Основными условиями объединения были сохранение восточнохристианского литургического обряда и наличия наряду с монахами также белого (т.е. женатого) духовенства. Акт о присоединении был подписан в 1595 г., а утвержден на соборе в г. Бресте в 1596 г. Это решение не было поддержано православным населением, казаками и большей частью духовенства. Так, одновременно с униатским, в Бресте состоялся альтернативный православный собор, который возглавляли экзарх Константинопольского патриарха Никифор, епископы Львовский Гедеон Балабан и Перемышльский Михайло Копыстенский, а также князь Константин Острожский. Собор отверг унию и подтвердил верность Константинопольскому патриарху.

Подписание Брестской унии, подготовка которой шла практически тайно, без широкого народного обсуждения, привело не к разрешению противоречий между католиками и православными на украинских землях, а к возникновению еще одной церкви – Украинской Греко-Католической. От Римо-Католической церкви ее отличает православная литургическая обрядность, наличие женатого священства, богослужение на родном языке. От Православной же церкви она отличается более фундаментально: признанием авторитета папы Римского как единственного главы христиан и наследника апостола Петра, признанием ряда католических догматов (о непогрешимости папы в вопросах веры, филиокве, о непорочном зачатии Анной Девы Марии и др.), обрядом причастия на пресном хлебе, запретом причастия детей до 7-12 лет и др.

Переход в унию Киевского митрополита привел к фактическому обезглавливанию Православной церкви на украинских землях. В защиту православия как веры предков однозначно и бескомпромиссно выступило украинское казачество во главе с гетманом Петром Конашевичем-Сагайдачным. В 1620 г. иерусалимский патриарх Феофан при поддержке и охране казачества посвятил в сан митрополита Киевского Иова Борецкого, в результате чего была возобновлена иерархия украинского православия.

Следует особо подчеркнуть, что в условиях отсутствия государственности в сознании большинства украинского населе-

ния православная вера отождествлялась с принадлежностью к украинской нации. Смена православия на католицизм была равносильна полонизации. По словам И. Огиенко, перестать быть православным стало тем же самым, что и перестать быть украинцем. Церковь стала центром украинской национальной жизни. Видя различные препоны для своего развития, украинцы инстинктивно тянулись к церкви как к единой институции, где можно было чувствовать себя украинцем (Огиенко, 1993, с. 121). Именно такое понимание явилось причиной широкомасштабных выступлений против унии во время крестьянских восстаний в 30-х гг. XVII в. и Освободительной войны под руководством Богдана Хмельницкого в 1648-1657 гг. Борьба за православие стала главным смыслом деятельности братств – Львовского, Киевского, Луцкого, братских школ, явилась основным содержанием полемической литературы.

Значение монастырского строительства для культуры Слободской Украины

Одним из последствий Брестской унии было массовое переселение украинского народа на восток, на земли так называемого «Дикого поля». Эта территория после ее заселения украинцами получила название Слобожанщина. (Слобожанщина или Слободская Украина – историческое название восточной части Украины, которая включала территории современных Харьковской, Сумской, Донецкой, Луганской областей Украины и частично Белгородской, Курской и Воронежской областей Российской Федерации). Причинами миграции на восток украинского населения были:

- а) дискриминационная политика Речи Посполитой;
- б) постоянная агрессия со стороны Крымского ханства и Турции;
- в) усиление господствующими слоями общества Речи Посполитой социального, национального и религиозного гнета;
- г) поиск новых земель, наделенных значительными природными богатствами.

Следует отметить, что данные причины приводили также к увеличению в народе привлекательности Московии как единственного в то время независимого православного государства. По выражению И. Огиенко, «все низы, как светские, так и духовные, тянулись к православному царю, где хотя бы религиозного гнета нет, где хотя бы в праздник не заставляют работать. Верхи же украинские, проникнутые шляхетским духом и обычаями, боялись той Москвы, потому что там бы они не имели тех прав, какие имели в Польше» (Огієнко, 1993, с. 162).

Переселение осуществлялось массово, целыми семьями, под руководством и при охране казачества. С собой переселенцы брали все возможное имущество, а также разбирали и грузили на возы свои деревянные церкви, везли колокола, иконы, церковные книги. Важным фактом религиозной жизни на новых территориях было основание монастырей. Ряд основанных слобожанских монастырей явились местом поселения монахов, бежавших из разоренных обителей на Западной Украине. Так, пришедшие с войском полковника И. Дзинковского монахи Ксенофонт и Иоасаф в 1652 г. выкопали пещеру на берегу Дона, что послужило началом Дивногорского Успенского монастыря. Одновременно с ним, в нескольких километрах ниже по течению Дона, был основан Шатрищегорский Преображенский пещерный мужской монастырь. Среди первых переселенцев на земли Дикого поля были и монахи Лебединского монастыря, что на реке Тясмине. В 1654 г. они основали Благовещенский монастырь на горе Ахтырь, который с 1724 г., после постройки нового собора, стал именоваться Ахтырским Троицким.

В условиях Слобожанщины каждое компактное поселение украинцев, пришедших из определенной местности и имевших свои обычаи, традиции и воспоминания об оставленной родине, стремилось иметь и свой монастырь на новом месте. Так, полковник И. Дзинковский, вышедший из-под Острога на Волыни с тысячей казаков и всем имуществом, в 1663 г. в основанном им же городе Острогожске открыл одну из первых женских обителей Слобожанщины – Успенский (Пятницкий) монастырь. Сумской полковник Герасим Кондратьев был основателем и щедрым ктитором (жертвователем) сразу двух монастырей – Сумского Успенского мужского (открыт в 1658 г.) и Сумского Предтечева женского (от-

крыт в 1687 г.). В начале 1660-х гг. был открыт Змиевский Николаевский монастырь, названный Казацким.

Казаками Харьковского полка был основан в 1673 г. Куряжский Преображенский монастырь. Среди его первых жертвователей имена известных людей на Слобожанщине – это харьковский полковник Григорий Донец-Захаржевский (?–1691), житель Харькова, мещанин Лонгин Федорович, полковой судья Тимофей Клочко. Видный представитель своего времени – родственник гетмана Самойловича Михаил Васильевич – открыл между 1680 и 1685 гг. в своем имении Михайловке Лебединского уезда Предтечеву пустынь.

История сохранила факты, когда сами основатели слобожанских монастырей – представители казацкой старшины – принимали постриг и были в них первыми игуменами. Так, полковник Иван Штепа около 1673 г. основал в г. Краснокутске Петропавловский монастырь, где и был первым настоятелем, а сотник Василий Григорьевич Думеченко был игуменом в собственном Сеннянском Покровском монастыре (открыт в период до 1682 г.). Это явление отражало общую для украинской духовной культуры рассматриваемого периода тенденцию приоритета духовного над материальным.

Всего на землях Слобожанщины в течение XVII – первой половины XVIII вв. украинскими переселенцами было основано более 20 православных монастырей.

В силу масштабности задач, которые переселенцам приходилось решать на новом месте, слобожанские монастыри являлись не замкнутыми религиозными организациями, а были связаны многогранными отношениями с местной территорией.

В условиях военного пограничья, каким являлась Слободская Украина в XVII – первой половине XVIII веков, основными функциями монастырей было участие в обороне края и его колонизация. Так, роль наблюдательного пункта Московского государства играл Святогорский монастырь, где располагалась военная «сторожа». Здесь постоянно находились «служилые люди», по три человека из Рыльска и Путивля. Передвигаясь вдоль Донца и «укрываясь в луке против Святых гор», они собирали сведения о намерениях татар, направлении их движения, количестве. Кроме того, и сами монахи, обитель которых находилась «на Крымской

стороне», обязаны были, принимая бежавших из неволи пленников, расспрашивать их «про татарский приход» и важную информацию передавать в Белгород (Святогорская общежительная, 1994, с. 21). Эти обязанности, фактически, делали монахов состоящими на государственной службе. Об оборонной функции Святогорья говорит и наличие здесь оружия. Так, в 1724 году в монастыре была 1 пушка, 30 ядер и 20 ручниц (Зверинский, 1890, с. 223), а в 1758 году уже 3 медных и 1 чугунная пушки, с которыми управлялся монах-пушкарь Иаков (Святогорская общежительная, 1994, с. 12). В указанный период пушки имелись и в других монастырях: в Дивногорском их было четыре (Багалій, 1990, с. 38), в Змиевском – две, «государева жалованья» (Фомин, 1916, с. 91).

Роль обителей в колонизации края осуществлялась путем освоения и заселения подданными прилегающих земель. Некоторые монастыри Слобожанщины были наделены или приобрели за деньги довольно обширные земельные угодья. Наиболее крупные наделы в XVIII веке имели Святогорский, Змиевский, Куряжский, Ахтырский, Сумской Успенский и Харьковский Покровский монастыри. Во второй половине XVIII века, когда опасность нападения татар снижается и функция обороны перестает быть актуальной, они получают возможность развития собственного хозяйства.

Общность происхождения, той исторической роли, которую монастыри играли в жизни Слободского края, естественно, накладывали на жизнь обителей свою печать, формировали объединяющие их общие черты, составляющие особенности монастырской культуры региона. Но, тем не менее, каждый слобожанский монастырь имел свое «лицо» – историю, экономику, хозяйство, традиции и авторитет. В деятельности ряда монастырей, наряду с уже перечисленными, выделяются функции, которые можно назвать «профилирующими» в жизни обители (Смолина, 2016).

Так, Харьковский Покровский монастырь после открытия на его территории Славяно-Греко-Латинского коллегиума становится центром просвещения как на Слобожанщине, так и всей Украине. Известно, что в Харьковском коллегиуме в 1759–1760-х годах преподавал выдающийся украинский философ, поэт Г. С. Сковорода. Кроме того, монастырь выполнял функцию усыпальницы: в нижнем Трехсвятительском храме Покровского собора в фамильных скле-

пах были похоронены члены известнейших фамилий Слободского края – Квиток, Донец-Захаржевских, а также видные архиереи.

Находившийся вблизи Харькова Куряжский монастырь в 70–80-х годах XVIII века приобретает роль культурного центра. Этому способствовала деятельность и личные качества настоятеля архимандрита Наркисса Квитки. Его высокий уровень образованности, широкая эрудиция, опыт светской и духовной жизни делали Куряжский монастырь местом паломничества элиты Слободского края. Особую атмосферу, насыщенную не только религиозными, но и эстетическими впечатлениями, создавало богатство храмовой утвари и великолепие праздничных служб.

Необходимо отметить типичную для монастырей вообще, но единственную среди обитателей Слобожанщины функцию Озерянской пустыни. Построенная на месте явления Озерянской иконы Божией Матери, она играла роль хранилища или территории пребывания этого местночтимого образа.

Однако наибольшим авторитетом обладал древнейший в крае Святогорский монастырь. О влиянии этой обители красноречиво говорит тот факт, что ряд монастырей, как древних, так и основанных в XIX веке, имели устав по образцу устава Святогорья. Среди них Куряжский, Ряснянский, Высочиновский, Спасов монастыри.

Из-за недостатка информации сейчас не представляется возможным определить профилирующие функции других монастырей края рассматриваемого периода. Необходимо лишь отметить, что и свое основное назначение – религиозного центра – такие обители как Чугуевская Владимирская, Аркадиевская и Гороховатская пустыни, Шатрищегорский и Вольновский монастыри в конце XVIII века выполняли не в полной мере. Этому препятствовало недостаточное количество иеромонахов и братии в них, что явилось одной из причин их закрытия. Среди других причин, которыми обосновывалась необходимость последовавшей монастырской реформы, называлось преобладание материальных интересов над духовными в жизни монахов и, как следствие, забвение ими дела благотворительности и милосердия. Как отмечал Д. И. Багалей, в XVIII веке монастыри более всего начали заботиться о собственном хозяйстве и материальном достатке и забыли свои высокие христианские заветы» (Багалей, 1990, с. 38).

Такое преобладание «земного» над «небесным» в культуре монашества было порождено реалиями XVIII века, сменой

культурных ориентиров. Проблемы как всей цивилизации, так и отдельного человека XVIII век стремился решать не усиленной молитвой, а просвещением. Ценности эпохи лежали вне религии, формировалась светская духовность и, хотя Церковь эпохи Просвещения принимала участие в государственном строительстве Российской империи (в отличие от Западной Европы), но лишь на правах одного из государственных институтов. Из благотворительной деятельности монастыря выхолащивался ее религиозный смысл, что привело к неправильному разрешению антиномий культуры монашества и к последующему ослаблению и частичному уничтожению этих христианских сообществ.

Вывод

Таким образом, следует акцентировать на значимости религиозного фактора в культуре украинских земель в X-XVII вв. С другой стороны, культурные особенности региона наложили свой отпечаток на само православие, которое было принято и формировалось не в рафинированном «западном» или «восточном» варианте, но специфическом «кирилло-мефодиевском». Этот тип православия определял:

- цивилизационную ориентацию государства и населения;
- отношения народа с другими народами и с природным окружением;
- национальную идентичность, которая отождествлялась с религиозной;
- вектор расселения народа и распространение украинской традиционности на новые земли;
- традиционно значимую, ведущую роль монашества в национальной религиозной культуре.

Определяющими для культуры региона данного периода являлся комплекс бинарных оппозиций, наиболее значительными из которых были: земное – небесное, национальное – религиозное, традиционное – инновационное, свое – чужое, монастырь – мир. Нужно отметить, что, несмотря на все сложности и коллизии, их разрешение искалось и находилось в плоскости компро-

мисса, смягчення напруженности противоречия, что также лежит в русле особенностей национального менталитета. Доказательством такому утверждению является, например, отождествление веры и нации в культуре, попытка объединения церквей, неактуальность противоречия между любовью к Богу и любовью к людям, взаимодействие и взаимовлияние светской и духовной власти и др. Актуальность такого подхода сохраняется и поныне. Курс на сглаживание противоречий весьма желателен в непростых условиях религиозной жизни современного украинского общества.

Литература

- Багалій, Д.І. (1990). Історія Слобідської України, Харків: Основа.
- Зверинский, В.В. (1890). Материал для историко-топографического исследования о православных монастырях в Российской империи, Санкт-Петербург: тип. В. Безобразова.
- Історія релігії в Україні: Навчальний посібник. (1999). за ред А.М. Колодного, П.Л. Яроцького, Київ: Товариство «Знання» КОО.
- Крижанівський, О.П.; Плохій, С.М. (1994). Історія церкви та релігійної думки в Україні, Київ: Либідь.
- Кузьмин А.Г. (2004). Крещение Руси, Москва, С. 16.
- Огієнко, І.І. (1993). Українська церква, Київ: Україна.
- Святогорская общежительная Успенская пустынь. (1994). Москва: Тип. Бахметева; Переиздание Святогорской пустыни.
- Смолина, О.О. (2016). Монастыри Слобожанщины: динамика художественного образа: монография, Северодонецк: изд-во ВНУ им. В. Даля.
- Смолина, О.О. (2014). Особливості культури українського православного чернецтва, Актуальні проблеми історії, теорії та практики художньої культури: зб. наук. пр., Нац. акад. кер. кадрів культури і мистецтв, Київ, Вип. 33, 243–251.
- Федотов, Г.П. (2001). Собрание сочинений. В 12 т. Т. 10. Русская религиозность. Ч. 1. Христианство Киевской Руси X–XIII вв., Москва: МАПТИС SAM & SAM, http://odinblago.ru/filosofiya/fedotov/fedotov_russkaya_relig/
- Фомин. П. (2016). Церковные древности Харьковского края (историко-археологический очерк), Харьков: Епарх. тип.
- Уайт, Л. (1990). Исторические корни нашего экологического кризиса, Глобальные проблемы и общечеловеческие ценности, Москва: Прогресс, 188–203.

Olga Smolina

V. Dahl East Ukrainian National University

**CULTUROLOGICAL PROBLEMS OF
UKRAINIAN LAND RELIGIOUS LIFE
IN THE X - XVII**

Abstract

In the theme of the religious life of the Ukrainian lands of the 10th-17th centuries, despite a significant degree of its study, discussion questions continue to arise. Their consideration from the standpoint of Cultural Studies makes it possible to pay attention to previously unseen aspects, to reveal gaps. In the light of modern complex processes of changing civilizational and axiological landmarks in Ukrainian culture, these topics have not lost their scientific relevance. Therefore, for example, there is a debatable question about the ecology of Slavic paganism, harmonious relations with the nature of the culture that it gave birth, and the miscalculations of Christianity in this area. The justification of the leading role of monasticism in Orthodoxy allows to ex-

clude it from the charge of provocation of modern environmental problems. No less controversial is the question of the version of Christianity that was accepted by Rus' and the specifics of the Kyiv Orthodoxy. Recognition of the difference between the basic images of Christ in the Byzantine and Slavic perceptions (G.P. Fedotov) makes it possible to identify the peculiarities of Kyiv Orthodoxy.

Overall, a set of binary oppositions was the determining factor for the culture of the region in this period, the most significant of which were: terrestrial - heavenly, national - religious, traditional - innovative, own - alien, monastery - world. It should be noted that their resolution was sought and was in the plane of compromise, softening the tension of the contradiction, for example, the identification of faith and the nation, the attempt to unite churches, the irrelevance of the contradiction between love of God and love for people, etc.

Keywords: religious culture, Kyiv Orthodoxy, Ukrainian lands in X - XVII centuries, binary oppositions, Ukrainian culture.

VLADIMIR MENTUS
Institute of Social Sciences, Belgrade

Religiosity and Life Satisfaction in economically Developed European Countries

Abstract

In this paper the relationship between religiosity and life satisfaction in economically developed European countries is examined. The data come from the last round of the European Social Survey, from 2016. This data gives an opportunity to analyze three dimensions of religiosity – self-rating religiosity, frequency of attendance of religious services apart from special occasions, and frequency of praying apart from at religious services. On the other hand, life satisfaction data is provided using the single-item self-rating scale. The data from more than 22,000 respondents from 12 economically developed European countries indicated very weak relationship between all examined religiosity dimensions and life satisfaction. In the discussion, possible explanations for lack of relationship between these variables are provided – in the first place by examining existing evidence that in economically developed societies religion has little importance for individual well-being.

Keywords: religiosity, life satisfaction, Europe, secularization, cross-section

Introduction

■ Religiosity is a behavioural and psychological phenomenon that could be defined as the degree to which beliefs in specific religious values and ideals are held and practiced by an individual (Delener, 1990, p. 27, as cited in: Yeniaras and Akarsu, 2016). To a large degree it shapes individual behaviour as well as cognitive judgmental processes such as life satisfaction (Yeniaras and Akarsu, *ibid*).

There has been much prior research on association between religiosity and different measures of well-being, and vast

majority of these reported some positive association between religiosity and life satisfaction, happiness, positive affect or some other measure of well-being (Johnson et al., 2008). One of the most comprehensive reviews about these relations is conducted by Koenig (Koenig, 2012). According to him, by mid-2010, at least 326 quantitative peer-reviewed studies had examined these relationships. Of those, 256 (79%) found significant positive relationship. Only three studies (<1%) reported a significant negative relationship. Similarly, of the 120 studies with the highest methodological rigor (7 or higher in quality on the 0–10 scale), 98 (82%) reported positive relationship, and only one reported a negative relationship.

Strong and repeated evidence indicates that religiosity has beneficial effects in nearly every aspect of social concern and policy (Fagan, 2006; Vladisavljević and Mentus 2018; Mentus, 2017). Specifically, the available data clearly indicate that religiosity is associated with: greater longevity and physical health, higher levels of well-being and happiness, perceived quality of life, higher levels of self-control, self-esteem, and coping skills, optimism, better mental health, higher levels of good work habits, higher levels of marital happiness and stability, stronger parent-child relationships, greater educational aspirations and attainment (especially among the poor), higher recovery rates from addictions to alcohol or drugs, higher rates of charitable donations and volunteering, higher levels of community cohesion and social support for those in need, larger support networks, more social contacts, and greater satisfaction with support, increases in civic involvement, lower divorce rates, less abuse of alcohol and drugs, lower rates of suicide, depression, and suicide ideation, lower levels of many infectious disease, less juvenile crime, less violent crime, less domestic violence etc. (Mochon et al., 2011; Johnson et al., 2008; Fagan, *ibid.*).

There are many possible explanations for such results. First, religiosity serves functions that fulfil inherent human needs; these functions include greater purpose and meaning in life, higher levels of social support and social capital, and positive coping strategies when facing loss or difficulties (Tay el al., 2014). There is increasing evidence that there are inherent universal human needs that, when fulfilled, could enhance life satisfaction, and this psy-

chological perspective may be traced back to evolutionary roots (ibid.). According to Sedikides and Gebauer (Sedikides and Gebauer, 2013), religiosity fulfils fundamental self-needs – self-esteem, control, uncertainty reduction, and meaning (connected with the individual self), attachment (connected with the collective self), and social belonging (connected with the collective self). These authors add that in cultures that particularly value religion, need fulfilment is associated with improved psychological adjustment. According to prior research, other authors also emphasize social support and prosocial behaviours that religiosity encourages, coherent framework that it provides, and coping mechanisms associated to religiosity that make stress and loss less intense (Mochon et al., 2011).

However, there are some relatively common limitations of the most of previous research. First, they are often based on non-samples and/or unrepresentative parts of the population (Yeniaras and Akarsu, 2016). Second, most findings to date are based on the US data (mostly General Social Survey) or a comparable survey in a single country, while there is a lack of cross-national research (with only few cases that directly focus on religion) (Okulicz-Kozaryn, 2010). Third, prior research generally evaluated religiosity as a one-dimensional concept with focus on religious attendance (Bergan and McConatha, 2001). So, as ten Kate and her associates (ten Kate et al., 2017) argue, although the claim that religion has a positive effect on life satisfaction finds widespread support in the literature, the relationship appears to be in need of further scrutiny. In the next part, the importance of dimensionality issue will be examined in detail.

Dimensions of Religiosity

As religiosity refers to the various dimensions associated with religious beliefs and involvement, more recent studies have stressed the importance of evaluating religiosity as a multidimensional concept focusing on subjective, cognitive, behavioural, and the social and cultural components (Bergan and McConatha, 2001). Dimensions of religiosity such as private devotion and existential certainty thus are

now also regarded as important components of this trait, and reliance on religious attendance as a sole measure of religiosity may be insufficient and lead to incorrect conclusions (*ibid.*).¹ This study defines religiosity in terms of both objective religiosity (praying and religious participation) and subjective religiosity (religious belief).

Ten Kate and her associates (ten Kate et al. 2017) explain importance of every of these dimensions for life satisfaction. When it comes to religious beliefs, one characteristic of religious individuals is that they adhere to religious beliefs that offer interpretations of the empirical world and the right role of the individual in it. Belief carries potential to cope with, and thus alleviate, experience of insecurity. Religious beliefs may make events more comprehensible and gives meaning on seemingly mundane affairs; religious individuals are thus less likely to perceive their problems as a threat. Religious beliefs as such may be important coping devices, allowing individuals to adjust to major life events more easily and offering a more stable view of the world. Also, religious faith provides moral guidelines which give a special value to individual's life, and this enhances self-perception as a good and virtuous person and may enhance an individual's sense of self-worth. The same group of authors add that traditional religions provide a sense of safety thanks to the idea that a divine force or God will ensure that all goes well, or at least will be well in the future; this further reduces feelings of stress about the future, which contributes to overall well-being. Religious beliefs may also be related to self-worth through the conviction that one is loved and valued by God.

Relating to the participation in religious services, ten Kate and associates (*ibid.*) write about cultural and structural benefits of it. Cultural benefit originates from the binding power of a common framework of meaning and the sense of belonging that comes with it. In other words, religious narratives, rites, and rituals form a system of symbols, which creates and maintains a sense of togetherness, group membership and identification with the group. These individuals share the same worldview and belonging to such a community may

¹ Bergan and McConatha (*ibid.*) note that this could be especially the case with older adults with physical limitations, who are unable to attend religious services regularly. Thus, at least for this population, certain dimensions of religiosity, such as private devotion and religious belief systems, may serve as more accurate measures of religiosity than participation.

be beneficial for individual well-being in several ways. It incites a sense of intimacy – members that are involved in religious participation feel that they matter to each other, fit within the group, and are accepted by its members, which fosters a sense of closeness. Sense of being accepted by like-minded peers has positive effect on individual well-being. Perception of intimacy may be protected by group boundaries, which safeguard the beliefs of group and the safety of its members. Feeling of emotional security is thus another important benefit of participation in religious services.

Structural advantages of religious participation lie in the larger amount of social relations which it embodies (*ibid.*). Belonging to a religious community may result in social spill-overs in nonreligious domains; for example, the religious are more embedded in a cohesive neighbourhood. In this way, religious participation serves as a potential source of social benefits in terms of self-esteem and social support, which may have positive effects on individual well-being. Religious participation also offers a variety of tools that are helpful in coping problems and has important role in coping strategies employed in times of stress; it is associated with higher levels of self-esteem and a sense of control, through the provision of social support in the form of love, caring, and sympathy; finally, religious participation gives a greater availability of social resources that aid coping with encountered problems and alleviate feelings of loneliness (*ibid.*).

Finally, when it comes to praying, along with religious beliefs, practicing religion in a private setting is a dimension of religiosity that can play a role in enhancing a sense of security and coherence (*ibid.*). Ten Kate and her associates note that religious activities such as praying are very important for developing a relationship with a divine other. According to them, religious attachment figures may serve as a source of support and companionship in stressful times and provide individuals with feelings of love, safety, hope, control, and an overall feeling of tranquillity. Also, as prayer and divine interaction strengthen the feeling of being valued and helped by a divine force, it may further gain a heightened sense of self-worth and control; personal prayer plays an important role in accounting for variations in depressive symptoms, anxiety, and self-esteem (*ibid.*). Ten Kate and her associates also note that in addition to praying, reading religious texts may explain why religiosity is positively related to life satisfaction –

through reading such texts, individuals may feel connected to the characters in them (which is especially the case if they face similar issues). In this way, identifying with these characters may help in dealing with a many type of problems – individuals may get ideas about how to behave and think in order to solve their problems. Individuals may also feel less alone in facing these problems when they perceive their own issues in terms of the situation of such characters. Religious texts provide the moral codes and guidelines for behaviour which may further help individuals to solve these problems, but also avoid risky situations and behaviours. Reading religious texts is thus may also lead to enhanced perceptions of control (ibid.).

In the next part, we present measures of dimensionality that we have used in this study, as well as the data processed.

Data and Measures

We have used the data from the last (eighth) wave of the European Social Survey, conducted in 2016. Every two years, beginning in 2002, in a number of European countries, European Social Survey supervises a large set of demographic and attitudinal questions to randomly selected, nationally representative population samples; the samples are consisted of those aged 15 and over in each country (Bullivant, 2018). The survey is a multinational partnership with exceptionally high standards of design, execution and cross-national comparability (Voas, 2007). Data are being collected using personal interviews supplemented by short self-completion questionnaires; a great deal of expert attention has been devoted to sampling strategy, translation, methods, and quality assurance, with the highest possible level of cross-national comparability (ibid.). This survey provides better coverage of issues related to religion than most general-purpose surveys, covering the three main areas of affiliation, practice and belief. Although the questions on how religious the respondent is and how important religion is to him/her do not measure beliefs directly, it seems likely that there is a strong association between these variables and strength of religious belief (ibid.).

The last wave of survey covers over 30 European nations, and isolated sample for this research consists of respondents from twelve

European economically developed countries. Examined countries are France, Ireland, Great Britain, Belgium, Germany, Austria, Netherlands, Sweden, Norway, Finland, Iceland, and Switzerland. Isolated sample consists of 22,521 respondents, with minimum age of 15 and maximum of 100 ($M = 47.14$, $SD = 18.86$), and with 50.8% of females, and 49.2% of males.

In European Social Survey, general life satisfaction is measured using question: "All things considered, how satisfied are you with your life as a whole nowadays?" The answers were on an eleven-point scale, where 0 meant "Extremely dissatisfied", while 10 meant "Extremely satisfied". Intensity of religious belief is measured using question: "Using this card, how religious would you say you are?", where 0 meant "Not at all religious", while 10 meant "Very religious". Religious participation is measured twofold: in terms of participation in religious services, on the one side, and frequency of praying, on the other side. Participation in religious services is measured using question: "Apart from religious activities at the occasion of social events as weddings, funerals, christenings, and circumcisions, about how often do you attend religious services these days?", where 1 meant "More than once a week", while 6 meant "Never". Frequency of praying is measured using question: "About how often you pray?" and the answers were the same as for participation in religious services.

Results

With regard to general satisfaction with life, the sample studied indicated a high level of life satisfaction overall (7.58 on an eleven-point scale) (Table 1). Nearly 80% of the sample rated their life satisfaction with 7 or more, and below 7% rated with 4 or less. The finding that in general, people are more often satisfied than dissatisfied with their lives is consistent with many previous researches, at least in economically developed countries. Religious belief is rated approximately as neutral, where nearly half of the respondents rated it with 4 or less, and less than 30% with 7 and more. Two dimensions of religious participation indicate even less religiosity. Only 2.5% of the whole sample attends religious services apart from special occasions every day or more than once a week, and 80% of the sample

only on special holy days, less often or never. Additionally, less than 25% of the respondents pray apart from at religious services every day or more than once a week, and 64% of them only on special holy days, less often or never.

Table 1: Descriptive Statistics

	N	Min	Max	M	SD
How satisfied with life as a whole	22479	0	10	7.58	1.875
How religious are you	22436	0	10	5.66	3.101
How often attend religious services apart from special occasions	22469	1	7	5.68	1.432
How often pray apart from at religious services	22317	1	7	4.98	2.356

Regression analysis indicated the predictor structure of life satisfaction: the statistical significance of the model is determined, but it is very weak ($r = .073$, $r^2 = .005$, $\Delta r^2 = .005$, $F_{(3/22258)} = 39.984$; $p < .01$), and all three dimensions of religiosity are very weak predictor of life satisfaction (table 2). The size of the sample is the reason for indicated statistical significance of the model. The results indicate that the investigated determinants, as a set, have a satisfactory degree of internal consistency ($\alpha = .792$), which indicate strong mutual association between three dimensions of religiosity, which is also consistent with much of a previous research.

Discussion

Having in mind results of previous researches, the lack of relationship between religiosity and life satisfaction indicated in this study is not expected finding. However, it is probably effect of the sample that we have used – since is consisted of individuals from exclusively economically highly developed societies. More specifically,

all twelve countries that the data were used from, are according to the classification of the World Bank highly developed,² with GDP per capita of at least 35 000 US dollars in 2016.³ Much of literature show that in context of high level of economic development, religiosity in fact has very little importance for individual well-being (Diener et al., 2011; Okulicz-Kozaryn, 2009; ten Kate et al., 2017; Jong, 2008; Jagodzinski, 2009).

Table 2: Multiple linear regression with life satisfaction as a dependent variable (n = 22479).

Independent variables	B	SE	Beta	t	p
How religious are you	.045	.006	.074	7.852	.000
How often attend religious services apart from special occasions	-.058	.012	-.045	-5.020	.000
How often pray apart from at religious services	.055	.008	.070	7.118	.000
R Square = 0.005; Adjusted R Square = 0.005; SEE = 1.87					
* B – unstandardized coefficients; SE – standard error; Beta – standardized coefficients					

The results generally indicate very weak relationship between all three dimensions of religiosity and life satisfaction.

One possible explanation for such findings could be found in the religious values hypothesis (Norris and Inglehart, 2004). It holds that the conditions that people experience in their formative years have a profound impact upon their cultural values and growing up in societies in which survival is uncertain is conducive to a strong emphasis on religion – experiencing high levels of existential security throughout one’s formative years reduces the subjective importance

² https://datahelpdesk.worldbank.org/knowledgebase/articles/906519#High_income

³ <https://data.worldbank.org/indicator/NY.GDP.PCAP.CD?end=2016&start=2016>

of religion for individuals. Consequently, according to this hypothesis, the demand for religion should be far stronger among low-income nations than among rich ones, and among the less secure strata of society than among the affluent. Norris and Inglehart add that as a society moves past the early stages of industrialization, and life becomes more affluent, people tend to become more secular. They also notes that analysis of data from societies around the world revealed that the society's level of economic development and other indicators of human development predict with considerable accuracy extent to which people emphasize religion and engage in religious behavior, even without taking into account the specific belief-systems of given countries, or the institutional structures of religion. The most crucial explanatory variables are those that differentiate between poor societies, and societies in which survival is so secure that people take it for granted during their formative years (*ibid.*).

Inglehart (2000) states that in the uncertain world of subsistence societies, the need for absolute standards and a sense that an infallible higher power will ensure that things ultimately turn out well filled a major psychological need. According to Inglehart, one of the key functions of religion was to provide a sense of certainty in an insecure environment – and physical as well as economic insecurity intensify this need. But peace, prosperity, and the welfare state have produced an unprecedented sense of security, which has diminished the need for the reassurance that religion traditionally provided (*ibid.*).

Diener and his associates (Diener et al., 2011) agree that religiosity's associations with life satisfaction may depend on whether a society faces very difficult living conditions – in societies with relatively favourable circumstances, high average life satisfaction is achieved by most people, regardless of religiosity. In other words, the benefits of religion for life satisfaction depend on the societal circumstances – religion helps in a coping with difficult circumstances and therefore is most beneficial when people's life context is difficult. Thus, societies with more difficult life conditions were much more likely to be highly religious. When people are frequently faced with permanent hunger, illness, crime, or poor education – all of which are relatively more prevalent and uncontrollable in poor societies – religion can have a stronger effect on well-being. In these societies, according to Diener and his associates, religiosity is thus strongly associated with life satisfaction.

On the other side, as the same group of authors note, economically developed societies, on average, are superior in meeting basic needs, education, safety, and longevity; they also have better infrastructure that safeguards against natural disasters and epidemic diseases; consequently, people there might feel less need for additional coping mechanisms beyond their personal resources. When circumstances become more secure, religiosity might decrease.

According to the same group of authors (*ibid.*), when one observes the religiosity of nations, it seems that the least religious nations are primarily stable and democratic nations with high economic development; on the other side, in contrast, the most religious nations are usually poor ones with substantial social problems. The effects of religiosity on SWB are positive in the nations with relatively bad conditions and in highly religious countries, and they are neutral or even may be negative in the least religious nations (*ibid.*). Diener and his associates conclude that, where people's needs are met, and they feel secure, they may feel more self-sufficient, and interest in organized religion may decline; in economically developed nations, people are better able to achieve high life satisfaction without the help of organized religion. In these societies, religiosity is less prevalent and religious and nonreligious individuals experience approximately same levels of life satisfaction (*ibid.*). Similarly, in words of Pargament (1997, as cited in: Pargament, 2002) religion might be particularly valuable to people when they are facing problems that push them to the limits of their own personal and social resources, exposing their basic vulnerability to the world; in response to situations that point to human insufficiency and finitude, religion offers much of possible solutions: spiritual support, ultimate explanations, a sense of larger, benevolent forces at work in the universe, and a purpose in life that holds sacred significance.

The second important factor is a person-culture fit effect, such that religious people had higher life satisfaction in religious nations but not in nonreligious nations (religiosity is most beneficial to life satisfaction when it is congruent with the culture, that is, if religion is widespread in the society); where organized religiosity is in the minority, religiosity does not have a clear benefit for life satisfaction (Diener et al., *ibid.*). In other words, in highly religious societies, the benefits of religiosity for life satisfaction are attenuated probably because even nonreligious individuals have high levels of social support and respect, as well

as life satisfaction; it appears that in very challenging societal circumstances, religiosity aids respect, social support, and purpose or meaning in life, which, in turn are associated with higher life satisfaction (ibid.). As more individuals enter religion, there is greater climate for religiosity which enhances religious capital – in less religious nations, the relationship between life satisfaction and religiosity thus is not evident, or even (according to some authors) may be negative (Tay et al., 2014).

Okulicz-Kozaryn (2009) agrees religion is context dependent and that at the societal level, the relationship of different dimensions of religiosity with life satisfaction is not the same for different countries and cultures. According to this author, religion is more important not only in religious societies, but also in countries with poor social welfare. Finally, ten Kate and associates (2017) add that it is found that in pluralistic contexts, where a variety of lifestyles are accepted, and personal freedom is encouraged, traditional religions meet fierce criticism, so it is possible that the degree to which a country is pluralistic also plays a role in determining the effect of religion on life satisfaction. All of these factors may be very important in countries examined here

Literature

- Bergan, A., and McConatha, J. T. (2001). Religiosity and Life Satisfaction. *Activities, Adaptation & Aging*, 24(3), 23–34.
- Bullivant, S. (2018). *Europe's Young Adults and Religion Findings from the European Social Survey (2014-16) to inform the 2018 Synod of Bishops*. St Mary's University, Twickenham, Uk; Institute Catholique de Paris, France.
- Diener, E., Tay, L., and Myers, D. G. (2011). The religion paradox: If religion makes people happy, why are so many dropping out? *Journal of Personality and Social Psychology*, 101(6), 1278-1290.
- Fagan, P. (2006). *Why Religion Matters Even More: The Impact of Religious Practice on Social Stability*. Background, 1992, Washington, DC: Heritage Foundation.
- Inglehart, R. (2000). Globalization and postmodern values. *Washington Quarterly*, 23(1): 215–228.
- Jagodzinski, W. (2009). Economic, Social, and Cultural Determinants of Life Satisfaction: Are there Differences Between Asia and Europe? *Social Indicators Research*, 97(1), 85–104. doi:10.1007/s11205-009-9555-1

- Johnson B., Brett Tompkins, R. and Webb, D. (2002). Objective hope: Assessing the effectiveness of faith-based organisations: A review of the literature, University of Pennsylvania: Center for Research on Religion and Urban Civil Society.
- Jong, E. (2008). Religious Values and Economic Growth: A Review and Assessment of Recent Studies, Nijmegen Center for Economics (NiCE) Working Paper 08-111, Nijmegen.
- Koenig, H. G. (2012). Religion, Spirituality, and Health: The Research and Clinical Implications. ISRN Psychiatry.
- Mentus, V. (2017). Validity and Reliability of Subjective Wellbeing Indicators in Sociological Research – the Measurement of Life Satisfaction, *Sociological Review*, 51(1), 157–180.
- Mochon, D., Norton M. I., and Ariely D. (2011). Who Benefits from Religion? *Social Indicators Research*, 101: 1–15.
- Norris, P., and Inglehart, R. (2004). *Sacred and secular: Religion and politics worldwide*. Cambridge: Cambridge University Press.
- Okulicz-Kozaryn, A. (2010). Religiosity and life satisfaction across nations. *Mental Health, Religion and Culture*, 13(2), 155–169.
- Pargament, K. L. (2002). The bitter and the sweet: An evaluation of the costs benefits of religiousness. *Psychological Inquiry*, 13(3), 168— 181.
- Sedikides, C., and Gebauer, J. E. (2013). Religion and the self. In V. Saroglou (Ed.), *Religion, personality, and social behavior*. New York: Psychology Press.
- Tay L., Li, M., Myers, D., and Diener, E. (2014). Religiosity and Subjective Well-Being: An International Perspective. In C. Kim-Prieto (ed.). *Religion and Spirituality Across Cultures*, Cross-Cultural Advancements in Positive Psychology 9, Dordrecht: Springer.
- ten Kate, J., de Koster, W., and van der Waal, J. (2017). The Effect of Religiosity on Life Satisfaction in a Secularized Context: Assessing the Relevance of Believing and Belonging. *Review of Religious Research*, 59(2), 135–155.
- Vladislavljević, M., and Mentus, V. (2018). The Structure of Subjective Well-Being and Its Relation to Objective Well-Being Indicators: Evidence from EU-SILC for Serbia, *Psychological Reports*, online first. doi: 10.1177/0033294118756335
- Voas, D. (2007). Surveys of Behaviour, Beliefs and Affiliation: Micro-Quantitative. In: *The Sage Handbook of the Sociology of Religion*, edited by James A. Beckford and N. J. Demerath, 144–66. Los Angeles: Sage.
- Yeniaras, V., and Akarsu, T. N. (2016). Religiosity and Life Satisfaction: A Multi-Dimensional Approach. *Journal of Happiness Studies*, 18(6), 1815-1840.

NEVEN CVETIĆANIN
IVANA ARSIĆ
Institute of Social Sciences, Belgrade

New Religiosity, Posmodern Age and Post-Materialistic Values

Abstract

This paper examines one of the most significant structural changes brought about by post-modern age compared with classical modernism. This structural change can be identified in the eruption of so-called post materialistic values that are evident in the very core ideology of post-modernity; the need for belonging and identity. What results is the creation of new post-modern identities as combinations of traditional forms of identities and emerging forms which were being discovered at the time. The eruption of post materialistic values is witnessed also by the accord between civil (democratic) society and conventional religions after World War II, which gives a new post-modern identity to the epoch. Apart from social movements, research results of so-called positive, or natural sciences, contributed greatly to the promotion of post materialistic values. This new, concrete reality of science in practice is manifested in two new modern paradigms- general relativity and quantum mechanics. This paper will finally reach the conclusion that the era of new post-modern «enchantment» is reflected in the phenomenon of post materialistic values and is opposite to Weber's modernistic «un enchantment» (Entzauberung) of reality.

Keywords: postmodern age, post-materialistic values, identity, new devotion, new scientific paradigms, the time of new enchantment

■ We are living at a time when religion has made a great comeback in the lives of ordinary people and in the basic flows of social and political life of societies all over the world, thus constituting an inevitable social power of our time. One hundred or two hundred years ago it seemed that forces of enlightening social emancipa-

tion would consign religion to the antiques cabinet together with other social phenomena obsoleted by the modern era.

However, religion proved itself as a resilient social phenomenon which survived all attempts of “emancipation” and “modernisation”. Therefore, from the perspective of the first decades of the twentieth century, we could say a paradox occurred when religion replaced modernity and not vice versa, as was expected by “prophets of the new age”, from the French Enlighteners to Nietzsche. Modernity was replaced by postmodernity, during which religion regained its vitality and strength compared to the classical modern era of the 18th and 19th century; previously confined to triggering “pure” religious movements, religion in postmodernity transcended the religious sphere and went on to inspire social and political movements also.

During the 20th century, religion retired modernity, helping the epoch to enter the postmodernity era due to “material fatigue” of enlightenment values. What led to the eventual rejection of these values was that the Enlightenment progress had throughout the World Wars, economic and political crises and violent revolution, showed its other, aggressive and dark side, to which Hegel dialectically indicated in his work “The History of Philosophy”.¹ Additionally, Horkheimer and Adorno fully developed this theory in their text “Dialectic of Enlightenment”.²

The aim of this paper is to examine the shift from modernity to postmodern age and from materialist values of Enlightenment to postmodern *post materialist values* that gradually returned religion to the public sphere and restored its social significance. Although enlightenment marches from the end of the 18th century presented an image which foretold the downfall of religion, the 20th and 21st century revealed that religion in fact had never lost its importance.

The weakening and fading of the classical Enlightenment paradigm with its materialism and mechanism can be associated with one of the most significant structural changes of the post-

¹ G. W. F. Hegel, *The Philosophy of History*, Batoche Books, 2001.

² M. Horkheimer, T. W. Adorno, *Dialectic of Enlightenment*, Stanford University Press, 2002.

modern age when compared with the beginning of modernism and its zenith – the advent of *post-materialistic values*.

In the 19th century, Alexis de Tocqueville prophetically announced the fall of post materialist values due to materialisation of modern society. When describing the society of the United States, Tocqueville explained « why the Americans display more readiness and more taste for general ideas than their forefathers, the English, 'while noticing that' if the human mind were to attempt to examine and pass a judgment on all the individual cases before it, the immensity of detail would soon lead it astray and bewilder its discernment: in this strait, man has recourse to an imperfect but necessary expedient, which at once assists and demonstrates his weakness. Having superficially considered a certain number of objects, and remarked their resemblance, he assigns to them a common name, sets them apart, and proceeds onwards ».³ Tocqueville was undoubtedly correct because it wasn't long before a spiritual reaction to enlightening mechanistic materialism initiated.

The first signs of weakening of post materialist values surfaced during the interwar period in the 20th century, when an irrational shift appeared, contrasting the rationality of the enlightenment model. Besides conventional religiosity, new spiritual and sometimes even occult cults began to form. For instance, National Socialists were frequently involved in the occult and paganism, while the renewal of conventional religiosity appeared in the German Catholic centre and British conservatives, who in order to upgrade its pragmatism, sought to strengthen the principles of Anglican Protestantism's investigation of structuralism⁴ had a great impact on the return of religion, cults and mythical thought among intellectuals. His research concluded that myth is not primitive irrationality (thought), as was thought during the modern era by Bacon. On the contrary, myth by its structure is not only identical to logos, but also mythic structures are logically even more precise than structures of modern "scientific" statements. Cassirer's research concludes that religions and myths present the coherent Weltanschauung which fulfils: firstly, people's necessity to irration-

³ A. Tocqueville, *Democracy in America*, A Penn State Electronic Classics Series Publication, 2002, pp. 497-498.

⁴ E. Cassirer, *Language and Myth*, Courier Corporation, 1946.

ally believe and; secondly, their desire to interpret the world meaningfully, i.e. satisfying their intellectual need. Consequently, religion and myths cannot be understood as simple mysticism, but as epistemological and practical orientation of an individual in order to provide meanings to their world. Hence, beliefs can navigate in practical orientation according to the individual. One step remains only from religion and myth as an individual's a priori structure to true religiosity, which had once again placed the Truth into the area of transcendental. This step was easy to take after structuralistic re-legitimation of religious and mythical opinion.

Liotard's postmodern attitudes had a significant impact on the return to religion, especially his famous saying – « point out to the invisible ».⁵ Although Lyotard himself rejects religious implications of his opinion, i.e. his delegitimization of modernist rationality, it wouldn't be wrong to assume that religion would spontaneously and coercively attempt to replace the shaken world of modernist meanings after previously mentioned postmodern delegitimization. Thus, Lyotard, although indirectly, has influenced the return of religion in modern life. In a way, he succeeded in fulfilling his childhood dream of becoming a Dominican monk (according to his biographies) after he had he given it up to study philosophy.

Nevertheless, as legacy of the 1968 student demonstrations and the hippie movement that antedated it, new cults and Eastern religions start to spread in the social life of Europe. Finally, the last phase of this spiritualization precipitated after the fall of the Berlin wall, in, until that moment, still materialistic and real-socialistic Eastern Europe, while suddenly conventional and traditional religions gain popularity as well as some new, alternative, religious forms. In light of these major events and changes, it can be deduced that this epoch, contrary to early modern Bacon's and Carthusians rationalisation and technisation, was characterised by a search for new directions, which although might not have directly opposed the technical civilization existing at the time, questioned its significance and boundaries.

The post-modern civil society in its prime, in the second half of the 20th century, became "the dissatisfied society", according to

⁵ J. F. Lyotard, *Šta je postmoderna*, KIZ Art Press, Beograd, 1995., pp. 24, 34.

Ágnes Heller. Therefore, by analysing Heller's stance, Vukasin Pavlovic pointed that « the separation from traditional behavioural norms and the establishment of universal values (that is, the wish of owning something transforms into the wish of owning itself; the wish of becoming famous for something transforms into the wish of becoming famous regardless of cause and at any cost etc.) has made needs in essence unsatisfiable, while an identity and an integrity of the personality have been in essence removed from an obtainable and particular frame of reference, and instead they are thrust into an endless orbit of universal integration in which the reaching of something does not lead to fulfilment, because what follows always is the emergence of a new desire (so-called consumer psychology is one of the most prominent examples of this metamorphosis) ».⁶

With the domination of consumerist mentality as one of the by-products of the modern democratic "emancipations", the foundation of civil society began to degenerate. After banishing social theology from the political sphere, which the democratic development had spread among the entire society, people, states and civil society became disorientated. They tried to compensate for the absence with hedonistic indulgence in consumer hysteria that allowed them to briefly overcome fear and insignificance. Regarding the crisis of political and philosophical modernism, Mihajlo Djuric wrote: « The modern movement is not reaching an aim by which it could be tranquilized and finalized. Newer and greater successes of modern production are revealing a frightening fact that the modern movement are futile in its core. Hence, where is no goal, there is no meaningful movement ».⁷

Contrary to this superficial consumerist "modernist" dissemination, during postmodernity, the main need became the necessity for uniting and *identity* which consumer society was unable to handle. Herein precisely lies the cause of the re-popularisation of conventional and alternative religions and cults as well as the phenomenon of new social movements which united around new "ultimate

⁶ V. Pavlović, *Emancipatorska energija društvenih pokreta*, u zborniku *Obnova utopijskih energija*, Istraživačko-izdavački centar SSO Srbije, Beograd, 1987., pp. 10/11.

⁷ M. Đurić, *Utopija izmene sveta*, IDN, Beograd, 1979., p. 9.

purposes”, i.e. eschatological goals, such as the ecological project of environmental protection.⁸ Opportunely, consumer post-civil society that slowly formed after the Second World War, allowed space for the creation of various groups which in their self-organization could defend themselves from the identity crisis. The concept of civil society was subjected to a variety of spiritual and religious upgrades, both conventional and alternative. In fact, Tocqueville considered that the stability of modern democratic and liberal society was impossible without these upgrades which should present the counterpoise of all possible individualistic-economic deviations.⁹ Tocqueville’s voice remained in the background for a long time, and only after the Second World War certain aspects of Tocqueville’s “controlling” demands to the liberal democratic order were affirmed, and have become particularly important in our time, when the Bretton Woods model of liberal capitalism is experiencing a crisis, and we face a real torrent of “identity” populist movements across Europe and the world that form an open partnership with various new-old religious patterns.

Namely, since the period of the French Revolution, democracy and civil society on the one hand, and conventional churches and religions on the other, positioned themselves as irreconcilable enemies, that is, as two completely different orders.¹⁰ But after the

⁸ This statement also concludes V. Pavlovic by saying « in all of this lies at least partially the explanation to the re-emergence of many religious cults today, both in the West and in the East; secondly, why they are greater in number and type; thirdly, why groups and therapies for psychological support are gaining popularity; and finally, the popularity of movements for ethnical and national emancipation, racial equality and cultural autonomy ». V. Pavlović, *Emancipatorska energija društvenih pokreta*, in *Obnova utopijskih energija*, Istraživačko-izdavački centar SSO Srbije, Beograd, 1987., pp. 10/11. V. Stanovčić additionally recognized an effort of the epoch, thus he points out that the optimism of industrial society replaced the pessimism of post-industrial society, which after the break of rationalism during the First World War, starting with the existential philosophy, shift into the seeking of new meanings, which finds in the sphere of the irrational, by religion being a part of it. V. Stanovčić, *Političke ideje i religija*, Čigoja Štampa, Beograd, 1999, tom II, pp. 121. – 124.

⁹ A. Tokvil, *O demokratiji u Americi*, Izdavačka knjižarnica Zorana Stojanovića, Sremski Karlovci, CID, Podgorica, 199 0., pp. 252, 255, 492-499.

¹⁰ This demonstrates papal encyclicals *Quanta cura* and *Syllabus* written in 1864 by Pope Pius IX by which he condemned liberalism and democracy

Second World War, a great reconciliation occurred between post-civil society and already mature democracy and conventional religious institutions that fit into post-civil order, which allowed them full autonomy in religious rituals, the autonomy of internal jurisdiction and provided them with security guarantees. Even the Catholic Church has accepted some of the French Revolution heritage, as can be seen from the encyclical of Pope John XXIII entitled *Pacem in Terris (Peace on Earth)* published on April 11, 1963. In this encyclical, not only the heritage of democratic-liberal development is recognized, but many contemporary problems are addressed, such as: the rights of workers, the humanization of the modern economy, human rights in general, the critique of colonialism and neo-colonialism, the determination for the increasing social engagement of women, the commitment to nuclear disarmament, the concerns over global equality, etc.

The reason why the churches after the Second World War are reconciled with democracy and liberalism should become apparent in the fact that during the whirlwind of war, the greatest danger to Christian understanding of freedom did not originate from that side, but from the side of national socialist paganism, that is, from the communist atheism.¹¹

An additional impulse for the attitude change, not only of Christian, but of all conventional religions according to modern trends, was the content of the *Universal Declaration of human rights* adopted by the United Nations in 1948, which departs from the rigid enlightenment of the *Declaration of 1789*, with similar content at first glance, while in essence, visible changes were made. Perhaps the most important change is the concession to monotheistic religions in the “metaphysical” and postulative defining of «inherent

as opposite to the Catholic doctrine. However, in 19th century certain liberal Catholics as Félicité Lamennais disputed these tendencies.

¹¹ After the Great Patriotic War, the Russian Orthodox Church turned again to the careful criticism of communism. Additionally, after the death of Stalin when a title of General Secretary of the communist party was given to persons, such as Khrushchev and Brezhnev, who did not own Stalin’s “theological” feeling, criticism of communism became even more obvious. However, Communism was different than Nazism, which was characterized by anti-Christian ideas and paganism; hence in the Soviet Union where was established the communist society, the Church survived and preserved its infrastructure.

dignity and of the equal and inalienable rights of all members of the human family»¹², where its origin is no longer sought in the enlightenment theory of a social contract. Instead *dignity* is simply postulated without remarks on its origin. This greatly pleased churches and other religious organizations. With pure conscience, they could have found the origin of the above-mentioned human “dignity” in God. The possibility of latent “metaphysical” connotations of the *Universal Declaration* was the reason for the representatives of the Marxist countries to abstain during the final vote on it in the UN General Assembly. Noting on this occasion that this declaration has no revolutionary implications, while it can serve the popularization of the “opium for the masses”, as orthodox Marxists referred to religion since their great founder.

In general, the reconciliation between the civil society and conventional religions after the Second World War was testified by a number of circumstances, from which we can conclude that the antagonisms cultivated at the time of the French Revolution between the enlightenment and conventional religious organizations were overcome. Now we have a blend of the principles contained in the *Declaration of Human and Citizen Rights* from year 1789, as a proclamation of a (liberal) revolution, with some of the Holy Alliance principles as a kind of restoration declaration. This is evident, for example, in the following documents of Catholic councils, such as *Gaudium et Spes* and *Dignitatis Humanae*, which relate to the *Pacem in Terris* encyclical, which equally count on democracy, liberalism and human rights, but stating the necessity of recognizing the church and churches as a stable spiritual order that will be one of the global balance savers.¹³ However, it will not be disputed that within the churches, and especially within the Catholic, some circles remain hostile to democratic novelties, but churches make their voices heard only within ecclesiastical organizations in order to prevent possible attacks due to inflexible conservatism.

¹² Universal Declaration of Human Rights, Preamble: https://www.ohchr.org/EN/UDHR/Documents/UDHR_Translations/eng.pdf - Pointed out by N. C.

¹³ For encyclicals *Gaudium et Spes* and *Dignitatis humanae*, and their contributions to the modern and “democratic” Catholicism, see: *Osnove socijalnog učenja katoličke crkve*, Fondacija Konrad Adenauer i Beogradska nadbiskupija, Beograd, 2006., pp. 6, 36, 66, 78, 80, 89, 104, 155, 164, 216, 220-222

Churches and other religious organizations in Europe after the Second World War generally accept democracy and some of the civil society segments, representing in that way one of the ethical controllers of any possible political self-will, while not being its sources any longer – such as in Tocqueville's or, even more, in de Mestre's time. The more balanced relations between religious organizations and civil society¹⁴ testify to the new signs of the epoch brought by postmodern time, and the visible contours of the so-called *post materialistic values*. Therefore, it is not surprising that some very interesting sociological researches show that voters in contemporary Western democracies are being less polarized according to social class and classical ideologies, and increasingly according to principle - for or against materialist, that is, post-materialist values.¹⁵ This further suggests that old ideological divisions have been overcome, and new differences and value orientations are being introduced into the political field. This will have consequences when it comes to the more noticeable disappearance of the classical division of the political field into left and right, in their currently recognizable ideological forms. We have its full expression today, when the populist movements of our time, while fighting against liberal democracy, blend the left and right-wing segments.¹⁶

¹⁴ The question whether the Church and religious organizations are parts of civil society is topic too broad to discuss it now. Therefore, according to Pantic, it can only be concluded that a post-modern religiosity is not always an obstacle to civil society. Pantic also stated that the relationship between civil society and religiosity is ambiguous, hence occasionally religiosity became an ally of civil society and sometimes even its opponent. Dragomir J. Pantić, *Dominantne vrednosne orijentacije u Srbiji i mogućnosti nastanka civilnog društva*, u zborniku *Potisnuto civilno društvo* ur. V.Pavlović, EKO CENTAR, Beograd, 1995, pp. 84.-87. Additionally, it's worth mentioning that, according to V. Pavlovic « it is difficult to refute the fact that the church does not represent civil society (especially in the development sphere of ethical principles which presents the base of civil society) », *Ibid.*, p. 249.

¹⁵ R. Inglehart, *Culture Shift in Advanced Industrial Society*, Princeton University Press, Princeton – New Jersey, 1990., pp. 280-286.

¹⁶ For the announcement of the time that commence "on the other side of left and right-wing" by mixing its narratives and the official confirmation of this announcement, see: Neven Cvetičanin, *Epoha s one strane leveice i desnice*, Službeni Glasnik-Institut društvenih nauka, Beograd, 2008, Neven Cvetičanin, *Državništvo modernog doba*, Arhipelag-Institut društvenih nauka, Beograd, 2016.

The focus is on entering the era of a new post-modern (post-industrial, post-civil) “enchantment¹⁷” that will be contrary to the Weberian modernistic “un enchantment” (Entzauberung)¹⁸, which represents the general place of modernist vocabulary, the initial capsule and the inner core of modernist development. As opposed to that, we will have a postmodern (post-industrial, post-civil) world that will no longer be strictly rational, and which will not be subject only to rational interpretations. Rationality here will constitute only one of the offered legitimate choices, while all irrationalities will also receive new-old legitimacy, introducing the strengthening of different religious fundamentalisms, that are already growing stronger, not only at some remote points of the world, but in Europe itself.

Apart from social movements, such an atmosphere is also the result of some studies of so-called positive and natural sciences, which are not able to indirectly reflect on the social movements themselves. Unlike the beginnings of modern science where “people are giving up of meaning”¹⁹ inaugurating bare scientific positivism, at the beginning of the postmodern era, in the era between the world wars and, especially after the Second World War, sense has been re-returned to science. But its sense was not restored by fitting it within the frames of some dogmatic metaphysics, as was the case in the pre-modern era, but *by restating again the question of its meaning*, which was long absent, and to which, now in the postmodern era, multiple answers are possible.

Lyotard raises this question and offers a multifaceted answer to it, and thus re-introduces the question of the body of scientific research ‘through the back door’, even though he refuses to accept that body in a logocentric manner like traditional metaphysics.²⁰ If Lyotard is correct, to use one of Jaspers expressions - “the

¹⁷ For this aspect of so-called post-modern era, see: Françoise Gaillard, *Novo začaravanje sveta*, in: *Postmoderna – nova epoha ili zabluda*, Naprijed, Zagreb, 1988, pp. 119–134.

¹⁸ M. Weber, *Gesammelte Aufsätze zur Religionssoziologie*, Tübingen, 1920/21.

¹⁹ M. Horkheimer, T. Adorno, *Dijalektika prosvetiteljstva*, Veselin Masleša, Sarajevo, 1989., p. 19.

²⁰ J. F. Lyotard, *Šta je postmoderna*, KIZ Art Press, Beograd, 1995., pp. 61. – 64.

spiritual situation of time²¹" - that is, the spiritual situation of modern science that is desperately seeking for a body, then the new concrete reality of science will in practice be embodied into two new contemporary scientific paradigms - general theory of relativity and quantum mechanics.

Namely, the general theory of relativity and quantum mechanics will not be represented as metaphysics in the traditional meaning of the word, but both of these scientific paradigms will imply some metaphysical conclusions that surpass simplistic scientific positivism.

Therefore, it is not surprising that quantum mechanics are often used by theists of all confessions, while the general relativity theory is used by certain neo-Spinosists. All this unambiguously states that the epoch shows signs of overcoming the narrow optics of modern mechanistic positivism²², replacing it with what we can call "partial metaphysics".²³ The philosophic equivalent to the physics of quantum mechanics is Jean Baudrillard, with his *Fatal Strategies*²⁴ in which the modernistic, omniscient, tireless and mechanistically-pragmatic Odyssey is replaced by a post-modern Odyssey, who is amazed by the new-old secrets of the once again "enchanted" world.²⁵

²¹ K. Jaspers, *Duhovna situacija vremena*, Književna zajednica Novog Sada, 1987.

²² If there is no significant antagonism between "general relativity" and Newton's "classical mechanics", GR is not denying it, but improving it. Therefore, "quantum mechanics" is changing its basic principles of investigation while switching the rationalistic relation of cause and consequence to half-metaphysical entities such as "quark" or "antimatter" - which are allowing for the possibility of category of probabilities, that is coincidences. The difference between classical and quantum mechanics are indicated in the same manner as the distinction between modern and post-modern age, although belonging to the same epoch. Since researchers of "quantum mechanics" exceeded, but not abolished the principles of classical mechanics, they are, therefore, as well as researchers of "classical mechanics", offspring of the same period and the same flow thinking.

²³ What we have named the "partial metaphysics", Lyotard called the "micrology". Jean François Lyotard, *Šta je postmoderna*, KIZ Art Press, Beograd, 1995., p. 64.

²⁴ J. Baudrillard, *Fatal Strategies*, Pluto Press, 1999.

²⁵ Gaillard points out that Baudrillard in the aforementioned work « is suggesting a reverse Odyssey, this time in the opposite direction; however, she is not inviting us to repeat the journey of Odysseus, but to free the

This world of “new enchantment” is not only the world of the return of old religious and literary myths, but also new media or virtual myths are possible, which also produce irrational behaviour, but, unlike those old myths, represent the real “implosion of meaning”, as expressed by Baudrillard.²⁶

The postmodern era thus, with its *post-materialist values* and the accompanying return of religion and religiousness as a relevant social force, offers its paradise, as well as its hell, but will, however, leave people the choice of which side to choose.

path, to unwind the destiny of mankind which has been integrated into delicate threads of the mind ». Gaillard by analysing Baudrillard are precisising the sin of prudent Odysseus because of which « the shifty deceptions, invented in order to resist the enchanting voices of the world full of meaning, stayed tied up to the mast of the mind, so we do not, seduced by fear, cross over to the side of the mermaids ». Françoise Gaillard, *Novo začaravanje sveta*, in: *Postmoderna – nova epoha ili zabluda*, Naprijed, Zagreb, 1988., pp. 132-133.

²⁶ Ž. Bodrijar, *Simulakrumi i simulacija*, Svetovi, Novi Sad, 1991, pp. 83–90.

Literature

- Baudrillard, Jean. (1999). *Fatal Strategies*, Pluto Press.
- Bodrijar, Žan, (1991). *Simulakrumi i simulacija*, Svetovi, Novi Sad.
- Cassirer, Ernst. (1946). *Language and Myth*, Courier Corporation.
- Cvetičanin, Neven. (2008). *Epoha s one strane levice i desnice*, Službeni Glasnik-Institut društvenih nauka, Beograd.
- Cvetičanin, Neven. (2016). *Državništvo modernog doba*, Arhipelag-Institut društvenih nauka, Beograd.
- Đurić, Mihajlo. (1979). *Utopija izmene sveta – revolucija, nihilizam, anarhizam*, Institut društvenih nauka, Beograd.
- Gaillard, Françoise (1988). *Novo začaravanje sveta*, u zborniku *Postmoderna – nova epoha ili zabluda*, Naprijed, Zagreb.
- Hegel, Georg Wilhelm Friedrich. (2001). *The Philosophy of History*, Batoche Books.
- Horkheimer Max, Adorno (2002). Theodor, *Dialectic of Enlightenment*, Stanford University Press.
- Inglehart, Ronald. (1990). *Culture Shift in Advanced Industrial Society*, Princeton University Press, Princeton – New Jersey.
- Jaspers, Karl. (1987). *Duhovna situacija vremena*, Književna zajednica Novog Sada.
- Liotard Jean, François. (1995). *Šta je postmoderna*, KIZ Art Press, Beograd.
- Osnove socijalnog učenja katoličke crkve. (2006). Fondacija Konrad Adenauer i Beogradska nadbiskupija, Beograd.
- Pantić, Dragomir J. (1995). *Dominantne vrednosne orijentacije u Srbiji i mogućnosti nastanka civilnog društva*, u zborniku *Potisnuto civilno društvo*, ed. V.Pavlović, EKO CENTAR, Beograd.
- Pavlović, Vukašin. (1987). *Emancipatorska energija društvenih pokreta*, in *Obnova utopijskih energija*, priredio Vukašin Pavlović, Istraživačko-izdavački centar SSO Srbije, Beograd.
- Stanovčić, Vojislav. (1999). *Političke ideje i religija*, Čigoja Štampa, Beograd.
- Tocqueville, Alexis de. (2002). *Democracy in America*, A Penn State Electronic Classics Series Publication.
- Universal Declaration of Human Rights: https://www.ohchr.org/EN/UDHR/Documents/UDHR_Translations/eng.pdf.
- Weber, Max. (1920/21). *Gesammelte Aufsätze zur Religionssoziologie*, Tübingen.

ЗЛАТКО МАТИЧ
Православный богословский факультет
Белградского Университета

Пост-традиционное христианство: православная церковь между ностальгией и антиципацией

Аннотация

Настоящее исследование – философско-теологический анализ феномена «пост-традиционного христианства» и попытка в основных пунктах представить потенциально конструктивный ответ Православной Церкви (православного богословия) на вызов такой проблематики. Наша цель – подчеркнуть необходимость дерзновенной реинтерпретации теологической концепции Предания (традиции), то, что нужно достать Святое Предание из архивных ризниц и сделать его жизненным. Для такого предприятия нужен диалог с современным миром в ключевых вопросах, понимание постмодерна, уважительное обсуждение его понимания времени, идентичности, истории и традиции. В соответствии с этим, необходимо предложить смелый шаг навстречу («диалогическая парадигма») с намерением преодолеть как гомогенный идентитет и гомогенную повторяемость (вместе с ностальгией по «потерянному раю»), так и наивные футурологии, которые угрожают и Церкви и миру. Диалогическая парадигма поэтому и не является пассивной, она не только проводник того, к чему мы пришли через предание, традицию; следовательно, такое состояние сближает нас, хотели мы этого или нет. Диалогическое начало призывает нас на подвиг поиска другого потому, что нас к этому обязывает любовь. А *priorium* христианства, как мы все знаем – любовь именно к врагу, не говоря уже о собеседнике или спутнике. Упомянутый принцип диалога поэтому и является не «улицей с односторонним движением», но событием встречи с другим и с отличиями его предания, которое меняет и нас и заставляет меняться и наше богословие, преображаться в новых вызовах и становиться более свежим и плодотворным.

Ключевые слова: пост-традиционное христианство, православное богословие, реинтерпретация традиции, посмодерн, диалогическая парадигма.

Введение

■ Тема настоящего исследования – философско-теологический анализ феномена «пост-традиционного христианства» и попытка в основных пунктах представить потенциально конструктивный ответ Православной Церкви (православного богословия) на вызов такой проблематики. Наша цель – подчеркнуть позицию, что необходимо сделать дерзновенную реинтерпретацию теологической концепции предания (традиции), то, что нужно достать Святое предание из архивных ризниц и сделать его жизненным. Для этой цели нужным является диалог с современным миром, понимание постмодерна, рассмотрение его понимания времени, идентичности, истории и традиции. В соответствии с этим, необходимо предложить смелый шаг навстречу («диалогическая парадигма») с намерением преодолеть как гомогенный идентитет и гомогенную повторяемость (вместе с ностальгией по «потерянному раю»), так и наивные футурологии, которые угрожают и Церкви и миру.

В соответствии с указанными исследовательскими предпосылками, доклад делится на несколько частей. Вслед за представлением основных особенностей нынешнего пост-традиционного христианства и критического богословского и социологического анализа его интеракции с современным миром (может быть, «постхристианским»), мы предложим ответ на вопрос, каковы шансы Церкви и её свидетельства в таких обстоятельствах, а в конце сделаем теологический вывод о призвании православия глубже прогрузиться в ризницы собственной традиции. Мы считаем, что там можно найти то, чего жаждет современный мир и человек – радикальность евангельского этоса любви, который основывается на одном специфическом предании и памяти, так называемое *memoria futuri*.

Концепт традиции в пост-традиционном времени

Основные богословские и социологические предпосылки современного плюралистического мира описываются разными способами. За потребности конкретного исследования мы прини-

маем понемногу обобщённые, но полезные, почти уже классические заключения Чарлза Тейлора, который идентифицирует три «смущения» (слабости или истощения) модерна: индивидуализм, инструментальный разум и лишение (политической) свободы. Другими словами, автор анализирует удаление цели из жизни и исчезновение свободы под доминированием инструментального разума, и это напрямую связывает с исчезновением смысла и чувства (нравственной) ценности предания (Taylor, 1992). В соответствии с этими предпосылками, и другие аналитики почти единодушно идентифицируют новое время, модерн с феноменом «отцепления от предания» определяют как «пост-традиционное движение» или «современный суррогат для истощенного содержания традиции (Хабермас)»¹. Исчезновение «великих притч историй» мета-повести Лиотара, удаление парадигмы абсолютных истин, мейнстримизация субъекта, который использует ум для того чтобы ничего не воспринять окончательным, закруглённым и неизменным, вызвал трансформацию понятия традиции. Предание (традиция) воспринимается как реальность, которая настойчиво лимитирует познание и свободу мысли, что ведет к процессу, который определяется понятием «детрадиционализация» – *detraditionalization* (Lelke, 2008). Расстояние модерна от традиции, «отдаление человека модерна от своей традиции» (Перовић, 2011:95-103), связано с понятием традиции как замкнутой, неприкасаемой, неизменной авторитетной реальности, которая не терпит критику, размышление, релятивизацию, на основе которых она укладывается в архив пре-модерных категорий.

Крушение традиции вообще означает «крушение традиционных категорий христианской метафизики», и это не надо доказывать. Святое Предание почти во всех своих видах уж долго находится «в кризисе понимания, а особенно в кризисе усваивания значения и влияния» (Крстић, 2012:25-34), которое должно быть проявлено в жизни христиан, как утверждает один теолог. Современный контекст общественной жизни (мы говорим о Сербии) помечен понятием транзитуции, чьей ключевой характеристикой является неуверенность. Технологическая научная цивилизация подняла на

¹ Пос. в. Lelke, „Tradicija“, у R. Šnel (ur.), *Leksikon savremene kulture*, Beograd, 2008, 701–702.

небывалую высоту мощь действий человека, но исключительно низко опустила порог предпосылок. Нет больше верных целей, декаданс ценностей отождествляется с равнодушием по отношению к ним. Современная духовность же, по сути, индивидуалистична – субъект (индивид, одиночка) является носителем действия без посредства традиционных норм и предпосылок². «В нестабильные времена верен лишь отход от традиций и традиционного, предмодерного общества, его (не всех) ценностей и понятий, что, в общей сущности вызывает серьезные последствия для нашей религиозности» (Крстић, 2018). Рефлексия уже упомянутой категории подразумевает то, что богословие должно серьезно принять во внимание вызовы плюралистического общества, которое требует «радикальное рассмотрение самопонимания традицией унаследованного и издревле подтвержденного наследия религии» (Bižica, 2008:323-326). Поэтому в двух слабостях, т.е. «в кризисе опосредования авторитета и начала традиции» усматривается завершение премодерного движения, которое маркировано знанием о постоянном отношении с трансценденцией, с божественным Бытием» (Dotolo, 2011:23). Поскольку упомянутые выше категории (Авторитет и Предание) являются конструктивными для христианства как церковного сообщества, очевидно то, что с кризисом опосредования традиции прямо связывается кризис христианской идентичности. Именно, вопрос идентичности, который всё чаще определяется как кризис идентичности, «маркирует современное общество, но и все Церкви и их теологии» (Ковачевић, 2017:145-159).

Некоторые авторы подход к преданию, который мы описали в введении, считают «одним из важнейших предубеждений» просветительского модернизма, которое надо пересмотреть потому, что традиция по отношению к их позициям является не обязательным антиподом модерна (Lelke, 2008:702). В контексте упомянутых попыток, наряду с философ-

² «При кризисе посредствования авторитетов и принципов традиции, значит, является конец предмодерной системы обозначенной сознанием о постоянном взаимоотношении с трансценденцией, с божественной сущью.», ср. Dotolo (2011:23).

скими³, надо совместить и богословское исследование существенно важного для жизни, сознания и веры Церкви понятия Предания⁴. Вызов своеобразной апологией предания через переосмысление его применения в настоящее время выражен и в богословии, и в социологических исследованиях. Апологетический же метод, смешанный с политическим подходом, порождает новые недоумения. В связи с этим, мы идентифицируем хотя бы два, по нашему мнению, ошибочных и особенно опасных способа анализа и понимания традиции. Это подходы традиционализма (как негативного феномена консервативизма) и его антипода, прогрессивизма.

Традиционализм

Попытка догматизированного и схоластического движения всех форм предания на уровень постоянных и неизменяемых форм представляет чрезвычайно плохой и контрпродуктивный феномен, присутствующий в разных теологиях и в других науках. Живописное и поучительное описание традиционализма представлен метафорой ежа на дороге (Vajsić, 1972:7-18). Речь идёт о знаменитой картинке реакции ёжа перед опасностью: мы все знаем, что он тогда свернётся, превратится в колючий клубок и ждёт ухода врага. Ёж это делает тысячелетия, это его «предание», это его традиционная реакция. Но он продолжает делать что-то похожее и тогда, когда люди стали пересекать его места обитания дорогами. Однако его базисная традиция не в состоянии сохранить его от движения

³ Распря Хайдеггера о бытии тянет его к анализируванию и темпоральных и исторических аспектов проблемы, таким образом и к вопросу наследия, наследства, традиции. Симпозиум Сербского философского общества, который проводился в сентябре в 2012 году, в городе Сремски Карловцы, был посвящён именно теме «Понимание традиции, традиция понимания», что подтверждает и актуальность темы.

⁴ Уп. Fisichella (2009:914-916). От православных теологов на потребности творческой перцепции Предания, чтобы Церковь была в состоянии решать проблемы времени и осуществлять дело спасения в истории, утверждая даже и то, «что мы, православные пришли к тому, что мы не знаем что делаем с нашей Литургией и преданием», указывает Зизиулас (2001).

транспорта и стальных врагов. Постоянное и неизменяемое предание, которое охраняло его, теперь ведёт его в заведомую смерть и угрожает привести целый биологический род к уничтожению.

Логика обороны и защиты собственного бытия или бытия своей группы способствует расширению ряда отрицательных появлений, которые угрожают аутентичному пониманию традиции. Такая логика легко может направить реакцию к интегризму и фундаментализму, который проявляется через нетерпимость и жёсткую исключительность. Она воспроизводит реакции парафундаментального типа⁵, которые осуществляются через «ностальгию за парадигмами смысла, которые способны направлять выборы и ценности...». Одной из самых частых является попытка полностью исключить неустойчивость переданной идентичности, закрепить «стагнацию» жизни, в силу чего невозможным становится создание идентичности, а таким образом и её охранение» (Dotolo, 2001:19). Уверенность в некоем континуитете, который сам для себя стал бы целью, на самом деле является ложным видением традиции, которая забывает вернуть креативность в процессе перенесения верования» (Dotolo, 2001:7). Копирование старых моделей и их навязывание в новых жизненных обстоятельствах только потому, что они «старые», вызывают уважительные реакции и с культурологической и с теологической точки зрения. Клерикализм (соотнесение всей Церкви только с клиром) и бюрократизм (формализм в отношениях вплоть до фарисейства) в церквях и христианских деноминациях являются чёткими проявлениями традиционализма как искушения в изучении и существовании предания. Опасность, которая идентифицируется нами в этом подходе – традиционная обеспеченность к традиции, религиозный навык, аrogанция европейского христианина. Вопрос, который здесь поднимается – Что из традиционалистического христианства является воистину христианским (церковным)?

⁵ Об этом писали в З. Матић (2004;855-876).

Прогрессивизм

Вторая сторона одной и той же реальности, ошибочного восприятия предания (традиции) – искушение потери любой связи с наследием, а таким образом и беспринципное изменение и отказ от него, под прикрытием модернизма и либерализма. Насколько опасным является подчинение и включение христианства в старые традиции, настолько вредным является попытка его субординации по отношению к старому веку, старому миру и новому порядку. И здесь мы отмечаем сосуществование уважительного желания к приспособлению (*aggiornamento*) традиционной христианской речи к новым жизненным обстоятельствам с одной, и поверхностного доверия к *novum* веку, через банализацию совокупной реальности, с другой стороны. Тогда теология с легкостью избавляется от неких одеяний, приписывая их Средним векам, в страхе, что традиционный символический и обрядовый (литургический) язык не является понятным современному человеку. Один мыслитель утверждает, что многие элементы традиции Церкви, когда столкнутся с постмодерном, больше не являются понятными или приемлемыми; традиция превратилась в непонятный язык (Domazet, 2001:423-436). При этом, всё-таки, некритическое снятие старых одеяний может привести к обнаженности идентичности предания и к потери традиционной радикальности христианского, евангельского послания. Референтная модель предания – больше не та христианская, она разлагается и теряется в прогрессивизме постмодернисткой эфемерности. Здесь важно заметить: в предложении на плюралистическом рынке христианские традиции не являются а priori отброшенными. С ними случилось что-то намного хуже, из них высосан жизненный сок Христова – нового и радикального – этоса общности и пасхального события, что является фундаментом христианского предания. Например: Библия стала не брошенной, она стала чтивом, стоящим филологического и литературного анализа; церкви не разрушенные, но в них ходят туристы; праздники выжили только как моменты индивидуального развлечения (Ночь накануне Рождества, Вербное воскресенье, Богоявление и многие другие праздники, которыми

Церковь литургически отмечает центральные моменты Святого Предания, воспринимаются ошибочно (магически или фетишистски) и используются для того, чтобы часть освященной природы внесли в профанное пространство). Традиция истинно церковного христианства не является больше спланивающим фактором, ещё меньше является носителем смысла Предания. В отношении экзистенциального выбора человека, «Церквам была предоставлена задача сохранения каких-то особенных, но не нужных видов христианской традиции» (Dotolo, 2001:157).

Первый вид современного искушения, которое стоит перед христианской традицией, традиционализм, обычно считается опасностью, которая стоит перед Католической церковью, а другой, прогрессивизм – перед протестантскими епископальными общинами. Все же известно то, что большое количество новых религиозных движений (направлений, обществ, братств во всех христианских деноминациях) очень легко могут быть описаны упомянутыми феноменами. Касательно, например, епископальных систем православной Церкви можно сказать, что за ними следуют явления, которые тоже могут указывать на интровертные и национально локализованные тенденции понимания предания, которые в случае эвентуального сочетания социополитических предпосылок могли негативно проявиться как традиционалистические. В следующей части настоящего исследования мы попытаемся описать, какой подход к преданию стал бы приемлемым для актуальной богословской мысли в контексте современной плюралистической духовности.

Церковь, традиции и ее теология предания в пострадиционном плюралистическом обществе

Об отношениях христианства и современной духовности выразительно говорит римский теолог, преподававший на Григорианском университете и в колледже Санкт Анселм, Г. Лафон, следующим образом: Верно то, что Церковь обладает Словом вечной жизни, но не каждая форма Церкви. Если возможна способность представить Церковь, то не потому ли это, что

формы Католической церкви, а может быть и всех церквей, в большей части способствуют смерти западной цивилизации, таким образом, каким раньше содействовали ее рождению? Только если мы закроем глаза перед фактом, что приливы и отливы, которые сегодня потрясают западную цивилизацию, потрясают и Церковь, мы будем в состоянии представить и другие формы, которые допустили бы Церкви пережить и одновременно содействовать нужном рождении нового мира. (Lafont, 1995:42-43).

По меньшей мере два акцента приведённой цитаты привлекли внимание своим христианским оттенком, которые и мы бы подчеркнули:

- 1) поиск новой идентичности традиционной Церкви (представимы и другие формы), и
- 2) потребность, чтобы и Церковь была активной и чтобы она внесла вклад в рождение нового мира.

Таким образом, анализ предания основан на двух категориях: первое указание говорит нам о повёрнутости к будущему (об эсхатологической вере в христианстве / Церкви), а второе – об этосе ответственности (о начале рождения нового, лучшего мира), к которому возможно направиться только по диалогической траектории.

В связи с первым пунктом, понимание веры и традиции в эсхатологической форме, мы перенимаем от Митрополита Пергамского, крупнейшего православного теолога, Иоанна (Зизиюласа), который говорит:

Церковь – идентичность, которая принимает и снова принимает то, что ей история предоставляет, но этот перенос никогда не касается только истории; он происходит таинственно, евхаристически, т.е. воспринимается как дар, приходящий в последние дни, как Бог обещал и приготовил для нас в Своём Царствии. (...) Предание перестаёт быть даром Духа, если оно является только делом исторического континуитета. (Зизиюлас, 2006:33-53).

Определённая реальность через само воспоминание получает в этом конкретном историческом моменте определённое значение и определённую ценность, становится осмыслен-

ной и оцененной. В конкретном событии прошедшее становится настоящим, через анамнез, повторный показ, обзор событий именно перед нами, их актуализацию. Память никогда не является только оживлением воспоминаний психологического типа о ком-то или чём-то, но и без исключений стремится стать одним креативным и эффективным событием, событием онтологического характера. Это и является предпосылками христианского богослужения, православной Литургии.

В эсхатологическом и богослужебном контексте, целое Предание являет анамнестический характер. Но воспоминание обо всем, что нас ради случилось, не имеет целью вернуть нас в прошедшее, ни свести прошедшее только до настоящего. Анамнез не заканчивается введением прошедшего в хронос, даже ни его присутствием, ни когда его помещаем в нынешнее время, потому что все и всё, о чём бы мы ни вспомнили, всё ещё осталось бы во владении смерти. Время передаётся в руки Божьи, чтобы Бог его исцелил и преобразил Предание в вечное ныне⁶. Суть не в концептуальном утверждении или определении реальности из прошедшего, но в их жизненности. Мы присутствуем в диалектике опыта и эксплицитного познания и его выражения. В этом и есть тайна своеобразного *memoria futuri*, ключевые определения веры и теологии традиционной христианской Церкви (Православной и Католической). Церковные сообщества призваны, чтобы всегда быть метафорой иного мира, ...знамением надежды, которая в состоянии перечитывать знаки дискретного, но решительного присутствия Церкви в истории (Dotolo, 2017:98). Предание, таким образом, становится живым и постоянным евхаристическим воспоминанием (*perpetuelle memorie*) веры Церкви, становится продолжением истории спасения, но и бывает свободно предложено стать и воспоминанием мира существования другим образом, возможностью жизни в общности. Традиция антиципирует будущее и ос-

⁶ Именно общность каждой локальной Церкви с апостольской общностью в истории создаёт одну нить Предания. Таким образом, традицию не понимают как простую передачу дара из поколения в поколение, но как общение в единой вере Церкви и в охваченных различных выражениях и партикуляризациях веры, всех поколений и всех пространств.

меливается освещать это будущее своим трудом во временности прошедшего.⁷

Касательно другого пункта цитаты Лафона, который мы анализируем, и который указывает на этос ответственности и диалога, мы предложим одну свою точку зрения на настоящий поиск диалогическим методом, который устоял бы перед критикой православного догматического богословия, особенно теологии Предания. Его мы назвали бы переводом богослужбной теологии общности в практику. Этос ответственности является практикой ответственности для другого, а диалог по определению зависит от другого. Такой подход является вызовом для каждой самодовлеющей и самозакрытой системы доктрины, для каждого стерильного догматизма и традиционализма. Им предоставляется хорошая возможность освобождения каждой верующей общины от абсолютизированного сознания о себе и своём исключительном предании, и ещё более глубокого подхода к традиции, как диалогического события, которое мы все вместе формируем и которое свою инстинктивность получает в процессе события (*in via*). Такое сочетание с другим является шансом на возрождение идентичности каждой религиозной общности, через воспитание исконных, а не искажённых традиционных предложений.

Такой метод впоследствии, наряду со своей компатибельности с богословием, имеет большое преимущество потому, что соответствует и духу времени, плюралистическому видению мира⁸. Общий способ существования христианского

⁷ Эти слова Блондела (Maurice Blondel), цитирует P. Henrici (2017:24-32).

⁸ Об этом писали в З. Матич (2017;255-270). Например: „Шансы и возможности огромны. Первым шагом было бы всеобъемлющее восстановление исконного богословского понятия Истины. Мы упомянули, что в настоящее время невозможно говорить об истине как сформированной и конкретной реальности. Как бы это не казалось странным, православная Церковь именно почивает на учении о том, что Истина – событие, что она возникает в процессе общности, что у нее нет догматических ценностей, а все это из-за идентификации истины с самим Христом, значит – с живой, свободной личностью. Церковь и мир могут участвовать в формировании Истины через ее происхождение. Вместо того чтобы исходить из позиции обладания Истиной, Церковь бы могла быть носителем майевтического метода рождения Истины в свободном диалогическом процессе вникания в чаяния конкретных людей 21 века. Диалогический вызов, следовательно, ставит перед

Бога, Святой Троицы, возносит диалог в сферы вечного божественного Бытия. Сын Божий, ставший человеком, своей Личностью свидетельствует о диалоге божественного и человеческого в одном бытии. Святой Дух является, прежде всего, Духом общности, или Духом диалога многих в одном Теле. Эта каноническое, специфичное отличие православия, этот знак личностной идентичности христиан направляет на диалогическую откровенность к другому любой ценой. Христианин не существует без другого, находя в нём собственный источник бытия, и чем больше другой становится иным, тем больше христианин является человеком Божьим. Именно, поучение христианского предания заключается в том, что Иисус Христос является человеком для других потому, что бытие для другого только и есть бытие Сына Божьего, Христа, того, чья любовь к Отцу является персонифицированной. Диалогическая парадигма поэтому и не является пассивной, она не только проводник того, к чему мы пришли через Предание, традицию, следовательно, такое состояние сближает нас, хотели мы этого или нет. Диалогическое начало призывает нас на подвиг поиска другого потому, что нас к этому обязывает любовь. А *piogium* христианства, как мы все знаем – любовь именно к врагу, не говоря уже о собеседнике или спутнике. Уже упомянутый принцип диалога поэтому и является не «улицей с односторонним движением», но событием встречи с другим и с отличиями его Предания, которое меняет и нас⁹ и заставляет меняться и наше богословие, преобразаться в новых вызовах и становиться более свежим и плодотворным¹⁰.

христианством и миром задачу изменяться, что не чуждо христианству, если принять Церковь как живое объединение. Так бы мы оказались на пути создания Истины до ее окончательной само-аффирмации в собственной деноминации" (266).

⁹ Уп. А. Russo (2011:145-171). Любому участнику критического и конструктивного диалога чем лучше знает другого, тем более поймет самого себя („ognuno comprende più adeguatamente se stesso, conoscendo meglio l'altro"). Похожие позиции мы отмечали в Матић (2013).

¹⁰ Пример хорошего диалога находим в примере существования «Закона Божия» в школах Сербии: «Существовавшие до сих пор план и программа православного «Закона Божия» имели целью вести диалог с конкретными молодыми людьми, чтобы этот разговор был экзистенциально важным, и чтобы он касался жизни молодежи. Они

Заключение

Когда Предание теряет свой смысл и когда становится сухой формой, фундаментом без надстройки, тогда оно легко поощряет традиционализм, интегризм, даже и модернизм, и все они могут проявиться и профундаменталистически. Так называемый традиционализм, т.е. настаивание на традициях без её истинного восприятия, очень легко может перерасти в фундаментализм. Понятие и содержание традиции (Предания) в его сыром, (нео)схластическом понимании линейного безжизненного континуитета, в равной мере опасно и в богословских и в других научных кружках, в равной степени угрожает и Церквям и социальному окружению. С такой точки зрения, мы все очень легко можем стать жертвами фундаментализма¹¹. Чтобы это не случилось, мы приглашены диалогически создавать Предание в, по Божьему желанию, различности. Традиции являются истинными, только когда мы их создаем, а не когда мы их пассивно проживаем.

исходили из имплицитного определения, что возврата к монолитному обществу или к религии больше не будет, а это приводило к выводу, что религиозный плюрализм тождествен с высшим вызовом переосмысления онтологического статуса всех религиозных объединений. Вместо борьбы с новым миром, «новым режимом» и вместо пустой ностальгии по прошлому, такая концепция «Закона Божия» исходила от того, что плюрализм предлагает религиозным системам, принимая во внимание потребности молодых людей. Автор учебного плана и программы ординарный профессор Богословского факультета в Белграде, епископ браничевский Игнатий (Мидич) считал, что «Закон Божий» должен вступить в отношение с новой системой, а не закрываться в себе, в своей ложной уверенности или закрытом догматическом гетто. Учебникам, которые он писал, был присущ сократовский метод рождения истины, а не высказывания с позиций утвержденных и застывших знаний. Диалогический вызов, соответственно, ставит христианство и мир перед задачей изменения, что отнюдь не чуждо христианству, если осознать Церковь как живое объединение, а не стерильный институт». Ср. (Благовевич; Матич, 2017:3-12).

¹¹ Уп. (Ватопедски, 2011:253-254). Автор говорит о верующих православных, но мы в парафразе пропустили конфессиональное слово, чтобы указать на универсальность проблемы религиозного фундаментализма.

Литература

- Bajsić, Vjekoslav. (1972). *Na rubovima Crkve i civilizacije*, Kršćanska sadašnjost, Zagreb, 7–18.
- Bižaca, N. (2008). „Ozbiljnost pluralizma“, *Crkva u svijetu*, 43, 323–326 (323).
- Благоевич, М., Матич, З. (2017). Религиозные перемены: православный катихизис в школьной системе Республики Сербии (2001-2017) // Научный результат. Социология и управление. – Т.3, № 4.
- Ватопедски, Јефрем. (2011). Превaziлажење верског фундаментализма. у Реч са Атоса, 240–254, Београд–Шибеник: Истина.: 253–254.
- Domazet, A. (2001). „Crkva – nositeljica tradicije u postmodernoj“, *Obnovljeni život*, 4, 423–436, 423.
- Dotolo, C. (2011). *Moguće kršćanstvo. Između postmoderniteta i religioznog traganja*, Kršćanska sadašnjost, Zagreb, 23.
- Dotolo, C. (2017). *Teologia e postcristianesimo. Un percorso interdisciplinare*, Queriniana, Brescia, 98.
- Зизиулас, И. (2001). „Символизам и реализам в православном богослуженију“, Саборност, 1–4, 13–35 (34).
- Зизијулас, Ј. (2006). „Апостолски континуитет Цркве и апостолско прејемство у првих пет векова“, Саборност, 1–2, 33–53 (52).
- Ковачевић, Д. (2017). „Kršćanski identitet u otvorenosti drugima i drukčijima“, *Diacovensia* 25, 1, 145–159.
- Крстић, З. (2012). „Црквена дисциплина под призмом канонског предања“, у *Id*, Православље и модерност. Теме практичне теологије, Београд, 25–34 (25).
- Крстић, З. (2018). Веронаука у служби васпитања за вредности, <http://veronauka.sabornost.org/zoran-krstic-veronauka-u-sluzbi-vaspitanja-za-vrednosti> (25.2.2018).
- Lelke, U. (2008). „Tradicija“, у R. Šnel (ur.), *Leksikon savremene kulture*, Београд, 701–702.
- LaFont, G. (1995). *Imaginer l'église catholique*, Cerf, Paris, 42–43.
- Mannion, G. (2007). *Ecclesiology and Postmodernity. Questions for the Church in Our Time*, Minnesota, 17.
- Матић, З. (2014). „Фундаменталистичке тенденције у енциклици *Quanta cura*“, Теме 2, 855–876.
- Матић, З. (2017). „Православна Црква пред духовним изазовима модерног света“, в: М. Blagojevic, Z. Matic (edd.), *Religion in contemporary society* (Религија у модерном друштву). International scientific meeting almanac, Belgrade, 255–270.
- Матић, З. (2013). Да истинујемо у љубави. Званични богословски дијалог Православне и Римске Католичке Цркве, Одбор за просвету и културу Епархије браничевске, Пожаревац, посебно 9–17, 183–187.

- Перовић, Д. (2011). „Conatus essendi и вопрос о Боге (Один аспект критики Левинаса западноевропейской онто-теологии)“, *Богословље* 71:1, 95–103 (95).
- Russo, A. (2011). „Unità di Dio in un mondo plurale“, у I. Sanna (ed.), *I fondamentali nell'era della globalizzazione*, Edizioni Studium, Rom, 145–171, 152.
- Саборност. (2011). 1–4, 13–35 (34).
- Taylor, C. (1992). *The Malaise of Modernity*, (cbc Massey Lectures Series), Concord, Ontario House of Anasi, 1991 *The Ethic of Authenticity*, Harvard Press, Cambridge, MA.
- Fischella, R. (2009). „Predaja“, *Enciklopedijski teološki rječnik*, Zagreb.
- Henric, P. (2017). „Tradicija: Kristovo znanje u nauku Crkve. Novo čitanje djela Mauricea Blondela 'Povijest i dogma'“, *Communio* 43, 130, 24 – 32, 29.

Zlatko Matić

**POST-TRADITIONAL CHRISTIANITY: THE
ORTHODOX CHURCH BETWEEN NOS-
TALIGA AND ANTICIPATION**

Abstract

The text presents the philosophical-theological analysis of the phenomenon of “post-traditional” Christianity and attempts to provide the constructive answer of the Orthodox Church to the challenges that this problem poses to it. The goal is to emphasize the need to make a daring reinterpretation of the conception of tradition, to extract it from the treasury of the archives and to make it alive. For such an undertaking, the dialogue with

the modern world is crucial, understanding of the postmodernity, consideration of the understanding of time, identity, history, and tradition. Therefore, it is necessary to suggest a vivid move towards a “dialectical paradigm” to overcome not only homogeneous identities and homogeneous repetition (along with nostalgia and lost paradise), but also naive futurology that afflicts both the Church and the world. The dialogical paradigm is not passive. Dialogical principle invites us to the quest to seek another because love for us is the obligation.

Keywords: post-traditional Christianity, Eastern Orthodox theology, interpretation of tradition, post-modern, dialogical paradigm

Notes on Contributors

Mirko Blagojević, Sociologist of Religion, Doctor of Sociology, Principal Research Fellow at the Institute of Social Sciences (Belgrade). His scientific work is focused on the attachment of people to religion and the church, with an orientation towards the research of Orthodox confessional spaces. Broadly, Blagojević explores global religious change, the processes of (de)secularization of Serbian and Russian society, and the study of youth and religion.

Dragoljub B. Đorđević, Sociologist, PhD in Sociology of Religion (1983), Full Professor of Sociology of Culture and Morality and Professional Engineering Ethics at the Faculty of Mechanical Engineering, University of Niš. He is a founder of Yugoslav Society for Scientific Study of Religion (1993; Honorary President 2008). He has published 460 scientific papers in journals, proceedings and books by other authors, including 32 books – he has also edited 72 collections of papers either independently or with co-authors. Seven of his books (*Natural Sciences Today*, *Sociology Forever*, *Skinheads*, *Sects and Cults*, *Speak Tavern Džerima – Tavern on the Outskirts and Its Surroundings*, *Pocket Sociology for Beginners*, *I Asked the Little Snail – My Sociological Story about Šaban Bajramović*) have been published in several editions in large circulations. His articles have been published in Austria, Bangladesh, Bosnia and Herzegovina, Bulgaria, China, Croatia, Czech Republic, Germany, Italy, Montenegro, Poland, Russia, Slovenia, Ukraine, and the USA.

Mijo Nikić was born in Gornji Zovik, Bosnia and Herzegovina in 1953. He completed his studies in philosophy and theology in Zagreb. He holds a master's degree in depth psychology from the Pontifical University of Gregoriana in Rome, and in 2002 he defended his PhD dissertation "The Image of God in New Religious Movements" at the Catholic Faculty of Theology in Zagreb. Since 1992 he has been teaching Psychology, Psychology of Religion and History of Religions at the Faculty of Philosophy of the Society of Jesus in Zagreb. He teaches eschatology at the DI Institute of Theology. He has published several articles in various journals. He attends national and international symposia. He is the editor of two collections: *New Religious Movements* (1997) and *Reincarnation and / or Resurrection* (1998). He has published two books: *The Image of God in Religious Followings and New Religious Movements* (2003) and *Family Psychology* (2004), and two booklets: *How to Overcome Fear by Faith* (2005) and *Faithful and True Images of God* (2006). He holds spiritual exercises for priests and nuns and psycho-spiritual seminars for managers on the role of spirituality in stress management.

Marina Jurčić graduated from the Faculty of Medicine in Zagreb. Within the field of medical psychology Jurčić promotes integral anthropology which takes into account its four dimensions: physical, emotional (psychic), social and spiritual. Jurčić has also specialized and elaborated on the topic: helping medicine and spirituality in overcoming stress, psychosomatic disorders, depression, psychocrisis, neurosis, burnout syndrome and posttraumatic stress disorder.

Dragan Todorović holds a PhD in sociology at the Faculty of Philosophy of the University of Belgrade (2011). He is an Associate Professor of *Introduction to Sociology* and of *Sociology of Minority Identities* at the Department of Sociology at the Faculty of Philosophy of the University of Niš. He is a president of the *Yugoslav Society for the Scientific Study of Religion* of Niš and editor-in-chief of *Facta Universitatis* within series: *Philosophy, Sociology, Psychology and History*, an international journal published by the University of Niš. Dr Todorović is a member of the *Commission for the Study of Life and Customs of the Roma* of the Serbian Academy of Sciences and Arts and was a President of the *Serbian Sociological Society* (2013-2015). Todorović is also involved in empirical and theoretical research of ethnic, religious and confessional relationships in present Yugoslavia and at the Balkans.

Yuri Stoyanov (PhD in Combined Historical/Religious Studies, the Warburg Institute, University of London Warburg Institute, University of London) is based at SOAS, University of London, and is a Senior Fellow at the Albright Institute, Jerusalem. His past assignments include Oxford, British Academy and Wingate fellowships and Directorship of the British Academy's Kenyon Institute in Jerusalem. He has acted as a visiting lecturer and professor at several universities in Europe and Asia. His publications include English-language books such as *The Hidden Tradition in Europe* (Penguin Books, 1994), *The Other God* (Yale University Press, 2000), *Defenders and Enemies of the True Cross* (Austrian Academy of Sciences Press, 2011) and edited volumes.

Vladislav Yeryomin - In 2011 graduated from the Faculty of Philosophy and Religious Studies of the State University of Informatics and Artificial Intelligence (Donetsk, Donetsk region, Ukraine). At the moment, Yuryevich Yeryomin is a graduate student of the Department of Philosophy, Cultural Studies and Information Services of the Volodymyr Dahl East Ukrainian National University (Severodonetsk, Lugansk region, Ukraine). His research interests include Platonism and Neoplatonism, Western esotericism, Integral traditionalism, Indian philosophy and culture, Tibetan Buddhism, and Postmodern culture.

Vladimir Bakrač is an Assistant Professor at the Faculty of Philosophy and Faculty of Political Science (University of Montenegro). Dr Bakrač has published a monography *Religions and Youth* and a *Glossary of Monotheistic Religions*. He is also the director of the Institute for Sociology and Psychology at the University of Montenegro and the director of a non-governmental organization engaged in scientific research on religion - Consortium for Religious Research – CREDO.

Predrag Živković is an Assistant Professor at the Faculty of Philosophy and Faculty of Architecture - University of Montenegro. Predrag Živković is actively engaged in sociological research which shows his participation in the realization of national and international scientific projects, studies, published monographs and papers. The most important fields of his scientific and theoretical interest and research are: sociology of politics, political philosophy and geopolitics. As a scholar of specialist doctoral studies, he spent the summer semester of 2013 at the Sociological Faculty of the Moscow State University, mastering in the field of geopolitics and sociology of international relations.

Emil Hilton Saggau is a PhD student and Church historian at the Section for church history, University of Copenhagen. His field of study includes: religion in South Eastern Europe and in particular Eastern Orthodoxy in the former Yugoslavian republics. He has authored series of papers on religion in Montenegro as well as Eastern Orthodoxy and violence. In 2018, he received the Miklós Tomka Award by ISORECEA for a paper on nationalism and religion and in 2019, an Elite Research Prize by the Danish Ministry for Science and Higher Education.

Zora Hesova is a Research Fellow at the Philosophy Institute at the Academy of Sciences of the Czech Republic and assistant professor at the Faculty of Philosophy, Charles University in Prague. She works on Islamic intellectual tradition, modern Islam in Europe and more generally religion in contemporary politics, with a particular focus on the Balkans and Eastern and Central Europe.

Kjell Magnusson is an Associate Professor of sociology at the Uppsala University. Dr Magnusson worked at the Departments of Slavonic Studies, Sociology, East European Studies, the Centre for Multi-ethnic Research, and the Programme for Holocaust and Genocide Studies. Thesis on *Yugoslavs in Sweden* (1986), books on *The Crisis in Kosovo 1981*, *The Rambouillet Accords* (1999), *Genocide as Metaphor. The Image of the War in Bosnia and Herzegovina* (2006). An unpublished book in English on *Theoretical Perspectives in Yugoslav Sociology of Religion* (1986). Empirical Research on nationalism and religion in former Yugoslavia.

Nada Novaković is a Research Associate at the Institute of Social Sciences (Belgrade). Her areas of interest are: social structure, social movements, the working class, inequalities, conflicts, unions and strikes, education, labour legislation and social policy. Dr Novaković has published papers in national and international scientific journals and proceedings. She has also published the following monographs: *Propadanje radničke klase: materijalni i društveni položaj radničke klase Jugoslavije od 1960. do 1990. godine*, (Dez) *integracija radničke klase druge Jugoslavije*, and *Radnički štrajkovi i tranzicija u Srbiji od 1990. do 2015. godine*.

Mariana Maksimović is a Research Associate at the Institute of Social Sciences (Belgrade). She is a research member of the project team “Modelling the Development and Integration of Serbia in World Currents in the Light of Economic, Social and Political Trends” funded by the Ministry of Education, Science and Technological Development of the Republic of Serbia. Selected publications: Maksimovic, M. 2004. *Human Resource Management in International Business*, IES, Belgrade; Maksimović, M. 2014. *Philosophy of Labour and Management in Japan*, Institute of Social Sciences, Belgrade; Maksimović, M. 2017. “International Human Resource Management and Demand for Talent”, in: *Serbia and the World - Challenges and Temptations*, Editor Grk, S, Institute of Social Sciences, Belgrade.

Natasa Jovanović Ajzenhamer completed her BA (2013), MA (2014), and PhD (2019) in Sociology at the Faculty of Philosophy (University of Belgrade). Her area of research focus are Sociology of religion and History of sociological theory. Currently she holds the position of Teaching Assistant at the Department of Sociology, Faculty of Philosophy, University of Belgrade. So far, Dr Natasa Jovanovic Ajzenhamer has published over twenty papers in scientific journals and books of proceedings, and she has participated in several scientific conferences. Also, she has been involved in several research projects and currently she is researcher at the Horizon 2020 project *Populist rebellion against modernity in 21st-century Eastern Europe: neo-traditionalism and neo-feudalism*.

Olga Smolina, Doctor of Science in Culture Studies, professor of Philosophy, Culture Studies and Informational Services Department of Volodymyr Dahl East Ukrainian National University. Author of monographs: “The culture of Orthodox Monasticism” (2014), “Monasteries of Slobozhanshchyna: Dynamics of their Artistic Image” (2016) and more than 100 articles on the history and theory of culture. Research interests: culture in religious, aesthetic and artistic aspects.

Vladimir Mentus is a Research Associate at the Institute of Social Sciences, Centre for Sociological and Anthropological Research. His research interests include a wide range of social psychology, economic sociology, and environmental sociology topics. He holds a PhD degree from the Faculty of Philosophy, Department of Sociology, University of Belgrade. He has been a visiting researcher at the Complutense University of Madrid – Faculty of Political Sciences and Sociology. He has published many papers in journals and proceedings of international importance, as well as in leading journals of national importance, and participated in a number of international scientific meetings.

Neven Cvetičanin is an Senior Research Associate at the Institute of Social Sciences in Belgrade and President of Institute's Forum for Strategic Studies. He obtained degrees in philosophy and political sciences. He has published several books and dozens scientific articles on political ideology, political philosophy/sociology, international relations, global analysis, the strategic geopolitical developments in the 21st century, politics of Western Balkans, etc. Between 2012-2014 he served as member of Serbian parliament – National Assembly and was a member of the parliamentary Committee for Education, Science and Technological Development and the Committee on Foreign Affairs.

Ivana Arsić graduated from the University of Belgrade, earning her Bachelor (2012) and Master Degrees (2013) in Classical Studies at the Faculty of Philosophy. Arsić studied at the Autonomous University of Barcelona receiving doctorate (2017) in Latin Philology and Cultures in Contact in the Mediterranean at the Department of Antiquity and Middle Age studies (Faculty of Arts and Humanities). Since 2018, she is working at the Institute of Social Sciences (Belgrade) as a Research Trainee. Arsić is culturologist and transdisciplinary researcher focused on cross-cultural relations in late medieval and early modern Spain and issues surrounding its identity and acculturation. Main topics of her research are: religious mentality, religious bureaucracy and institutions, acculturation and deculturation, the term of coexistence (*convivència*) in multiculturalism and multi-confessionalism.

Zlatko Matić is an Assistant Professor at the University of Belgrade - Faculty of Orthodox Theology (Dogmatic Theology) and a vice dean. He completed his basic studies at the Theological Faculty in Belgrade, postgraduate preparation at the Ecumenical Institute in Bari and the Theological Faculty of the Papal University *Gregoriana* in Rome. He received his doctorate at the Faculty of Orthodox

Theology in Belgrade, working on the Pope's primacy in the work of J.-M. R. Tillard (published: *Primacy of the Bishop of Rome*, Pozarevac-Belgrade, 2018). He published monographs *Speaking the truth in love. Official Theological Dialogue of the Orthodox and Roman Catholic Church* (Pozarevac, 2013) and *That there should be no division in the body. Essays from comparative theology* (Pozarevac-Belgrade, 2018) and about fifty professional and scientific papers in the field of dogmatic theology, comparative theology, Christian sociology, church education and church history.

CIP - Каталогизација у публикацији
Народна библиотека Србије, Београд

316.74:2(082)
316.322:2(082)
2-67(082)

TRADITIONAL and non-traditional religiosity : (a thematic collection of papers of international significance) / edited by Mirko Blagojević, Dragan Todorović. - Belgrade : Institute of Social Sciences ; Niš : Yugoslav Association for the Scientific Study of Religion JUNIR, 2019 (Belgrade : Faculty of Technology and Metallurgy, Research and Development Centre of Printing Technology). - 298 str. : ilustr. ; 22 cm. - (Series Edited volumes)

Radovi na engl. i rus. jeziku. - "Prepared as part of the project 'Social transformations in the European integration process: a multidisciplinary approach' ... (III 47010)" --> kolofon. - Tiraž 150.
- Str. 7-11: Religious change - traditional and non-traditional religiosity / Mirko Blagojević. - Notes on contributors.
- Napomene i bibliografske reference uz radove. - Bibliografija uz svaki rad.

ISBN 978-86-7093-227-2 (ISS)
ISBN 978-86-86957-21-4 (JUNIR)

а) Социологија религије -- Зборници б) Религија -- Друштво
-- Зборници в) Глобализација -- Религија -- Зборници

COBISS.SR-ID 281221388

Language proofreading: Ivana Arsić, Ph.D. | **Graphic design and layout:**
Milorad Mitić | **Print:** 150 copies | **Printed by:** Faculty of Technology and
Metallurgy, Research and Development Centre of Printing Technology
