



## MANUFACTURABILITY ANALYSIS OF DIE-CAST PARTS

Miloš Ristić<sup>1)</sup>, Miodrag Manić<sup>2)</sup>, Boban Cvetanović<sup>1)</sup>

<sup>1)</sup> Higher Technical School of Professional Studies – Niš, Aleksandra Medvedeva 20, 18000 Nis, Serbia

<sup>2)</sup> Faculty of Mechanical Engineering, University of Niš, Aleksandra Medvedeva 14, 18000 Nis, Serbia

[milos.ristic@vtsnis.edu.rs](mailto:milos.ristic@vtsnis.edu.rs), [miodrag.manic@masfak.ni.ac.rs](mailto:miodrag.manic@masfak.ni.ac.rs), [boban.cvetanovic@vtsnis.edu.rs](mailto:boban.cvetanovic@vtsnis.edu.rs)

**Abstract:** Manufacturability analysis of a product is used at early stages of a design process in order to assess the possibilities of product realization, reduce the number of design iterations, thus also reducing the cost. One of the conditions for the automated manufacturability analysis is parametric modeling and feature-based design. This paper presents the concept of the system for the manufacturability analysis of die-cast parts. It presents the way to create knowledge basis containing recommendations and restrictions used for die-casting of a part. The paper also describes advice CA system gives the designer during the design process by means of which the design process itself is upgraded and the concurrent engineering environment is created.

**Key words:** manufacturability analysis, die-casting, part attributes, feature recognition.

### 1. INTRODUCTION

Die-casting is a method of producing finished castings by forcing molten metal into a hard metal die, which is arranged to open after the metal has solidified so that the casting can be removed (Fig.1).

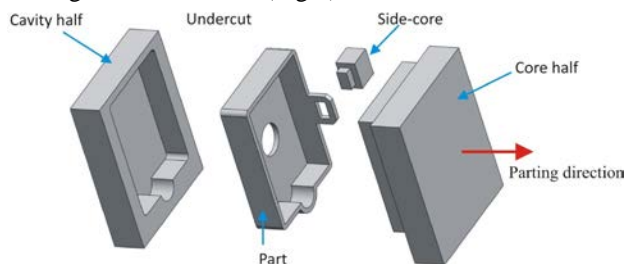

Fig. 1. Die-casting process terminology

Die-casting is a 'near net shape' manufacturing process extensively used for realizing quality products required in many engineering applications [1]. Advantages of die-casting process are higher production rate, lower cost, better quality and process automation. A part to be made with die-casting should be designed keeping in mind many process considerations. Involving production engineers in the product development during the design phase is the process of concurrent engineering which has the aim to get critical suggestions and advices related to part design which is, in fact, manufacturability analysis. Industries today are striving to achieve lower product development time, higher productivity and efficiency. In large enterprises, where design and manufacturing personnel may be stationed at different locations, the concept of Design for Manufacture (DFM) is preferred [2]. Implementing DFM will have the benefits of improved manufacturability of product design, shorter time-to-market and reduced cost. Three areas where DFM can be applied are: Verification; Quantification and Optimization [3]. Gupta et al [4] have classified DFM into

direct or rule based approaches. In rule based approach, rules are used to identify design attributes which are beyond process capabilities, while in direct based approach the first step is to generate feasible process plan and to find most suitable plan in order to reduce time or cost. Shah and Wright [5] have identified DFM metrics which include qualitative (good practice rules etc.) and quantitative (cost and time estimates etc.) methods. Most of the work in DFM has been done in the machining [4,6] or sheet metal processing [7,8] domain, while little attention has been given to die casting. In die-casting, implementation of DFM is important as production lead times are significantly longer. This is due to greater number of iterations required between design and manufacturing teams; die design and manufacturing, and process simulation and testing are required before production is started [1]. Certain progress in reducing production lead time has been achieved in the area of mold design. [9, 10]. Manufacturability analysis of feature based model has great importance during virtual product development [11].

### 2. FEATURE-BASED DESIGN AS A PREREQUISITE FOR MANUFACTURABILITY ANALYSIS

Manufacturability analysis requires the application of feature-based modeling techniques which, besides geometrical descriptions, contain technological recommendations and restrictions [12]. Depending on the manufacturability analysis moment, two approaches can be defined: analysis during the design process itself (on-line); analysis done upon the completion of the constructing process (off-line).

If the term "feature based design" [13] is used and if the product database, in a specific CAD system, is object-oriented, then we can perform on-line analysis. One of the

possible ways to do it is to do it during the constructing process, i.e. during the process of inserting certain elements in the product model and to automatically correct inserted value of a certain parameter if necessary. Another approach to manufacturability analysis is the analysis after the design process completion. Using this approach the whole product model would be analyzed and, if certain illogicalities are observed the report could be sent to the designer. This report may take the form of a warning, or alternatively the model could be changed and this changed model sent back to the designer. This off-line analysis approach is implemented using an expert system with the expert shell where, as in the case of an on-line analysis, the product model is object-oriented. Both analyses are based on parametric design and feature based project modeling. In order for a feature to be functional its attributes and characteristics have to be thoroughly described. Feature attributes carry the information about specific feature characteristics important for a current application and they can be determined at different levels- from the feature level, or feature set level to the level of describing part or an assembly [14]. Attributes can also be used to determine characteristics of a relationship between features and feature sets. Feature attributes can be position, orientation, dimensions, shape or tolerances. Assembly attributes can, besides other things, contain the information such as: assembly surface, overlaps/gaps, relative orientation.

### 3. PROCESS CONSTRAINTS AND DESIGN GUIDELINES

A part to be die-cast should possess certain design characteristics to make it suitable for manufacturing with die-casting process. Following sub-sections elaborate these constraints and guidelines.

#### 3.1 Part Geometry Limitations

Hui [15] has discussed some of the geometric aspects related to mouldability of a part. According to Madan et al [1] some features which cause accessibility problems are not allowed in die-casting. These are explained in the following paragraph with the help of figure 2 (a-f):

- Internal undercuts are not allowed in die-casting.
- Features with reverse draft and void features.
- Partially visible depression features like holes with smaller opening diameter and larger diameter at the base.

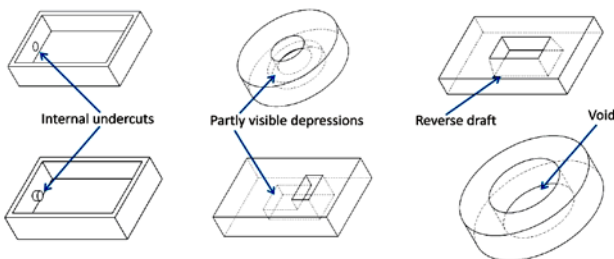

Fig. 2: Part geometrical limitations.

#### 3.2 Overall Part Attributes

Die casting process has limitations on overall part characteristics, such as part weight, surface area, wall thickness, material, size, tolerance and surface finish. These limitations depend on the type of material which makes it necessary for the designer to evaluate part against material specific process constraints. Table 1 shows representative database of material specific process capabilities.

Tab. 1: Die-casting material and process constraints (source: [15, 16])

Attribute		Material			
		Zn	Al	Mg	Cu
Weight (kg)		30	45	16	7
Effective projective area (m <sup>2</sup> )		0.77	0.77	0.77	0.77
Recommended minimum wall thickness (mm)					
surface area (cm <sup>2</sup> )	<25	0.38-0.75	0.75 - 1.3	1.5-2.0	
	25 - 100	0.75-1.3	1.3 - 1.8	2.0-2.5	
	100 - 500	1.3-1.8	1.8 - 2.2	2.5-3.0	
	500 - 2000	1.8-2.2	2.2 - 2.8	-----	
	2000 - 5000	2.2-4.6	2.8 - 6.0	-----	
Minimum wall thickness		<b>6</b>	<b>6</b>	<b>6</b>	<b>6</b>

#### 3.3 Good practice rules

There are certain rules in die-casting part design which should be followed in order to make a good part. There are many such good practice rules, some of which are shown in Figure 3.

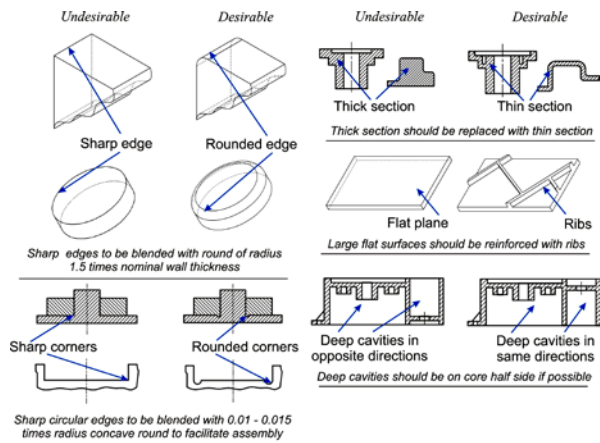

Fig. 3: Good practice rules in die-casting (Source: [16, 17]).

#### 3.4 Manufacturability of Individual Features

Some recommendations regarding individual feature characteristics in die-casting should be followed in order to make a good part. Design rules for ribs in die-casting, limitations on hole diameter and their relationship with core length, as well as tolerance limitations for a die-casting part, are described in the following sections of this paper.

#### 4. PART ATTRIBUTES AND FEATURE RECOGNITION

Feature recognition is a key for automation of any automated manufacturability evaluation system and that also applies to die-casting process [1]. Geometric reasoning or feature recognition rules are applied to get and store required information of die-casting features. Feature recognition is done in following domains: Non-manufacturability features, Features requiring side-cores, Part attributes, Wall thickness, Sharp edges, and Rib features.

Any features or regions of the part which pose molding tool disengagement problems are identified so that same can be reported to the designer. Side-core diameter and maximum length limitations depend on the type of alloy used. Recommended tolerances for die-casting part [16,17] also depend on material.

During manufacturability analysis of die-casting parts, determination of parting direction is important for identifying those die-casting features which require a side-core for molding.

Overall attributes of the part such as volume, surface area are directly extracted from the part CAD model, while tolerance and surface finish evaluation is performed interactively because of non availability of this data in machine readable format.

It is important to identify regions of the part which violate thickness constraints like minimum and maximum allowed wall thickness and even sharp thickness variations [18]. It is very critical in die-casting process to obtain parts with uniform wall thickness and smooth variations.

Die-casting process requires that, as much as possible, sharp edges be rounded or smooth, therefore the process of edges identification is important in the whole manufacturability analysis assessment. It is important to identify both sharp edges and smooth edges with insufficient round radius.

Rib features are those protrusion features in die casting which have wall thickness comparable to the nominal wall thickness and much larger length.

Taking into consideration part attributes and feature recognition, we can create rules and give advices to the designer. Depending on the available computer aided systems for manufacturability analysis, we opted to include necessary rules into parametrically designed gear housing (fig. 4).

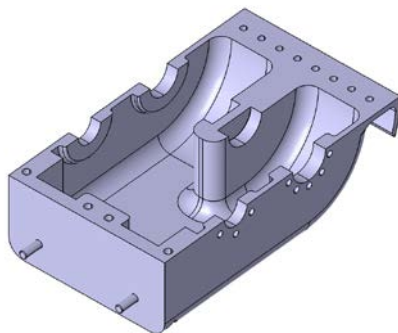

Fig. 4: Parametrically designed reductor housing.

Considering the fact that during the parametric designing each feature was defined and related, we can include

adequate relations. This was done by defining features using CATIA V5 (Knowledgeware) software. Using CAX Template, which contains information and inserted knowledge necessary to the expert, we define Knowledge Embedded Template – KET [19]. For example, sharp corners are undesirable because they become a localized point of heat and stress built-up in the die steel, which can cause die cracking and early failure. This is done by using rounding off sharp edges of the part. Manufacturability restrictions are directly inserted in parametrically designed product model in the form of rules. Radius of this round depends on the wall thickness of the part and is generally 1.5 times wall thickness. This rule can be of a great importance when a designer modifies parametrically defined product. If he wants to change radius user defined feature at the same time keeping the wall thickness, he will get an advice stating “radius  $r_2$  should be 1.5 times greater than the wall thickness”.

The rule was inserted in CATIA V5 Knowledgeware in the following form:

```
If 'Fillet_Radius_Value' < '1.5*Wall_Thickness'  
{  
    Message (“Radius should be 1.5 times greater  
    than the wall thickness !  
    Modify a parameter according to the rule.”)  
}
```

And as such was tested at a reductor housing. The figure 5 presents the advice in the form of information given by knowledgeware to a user who wants to change the described radius outside restrictions.

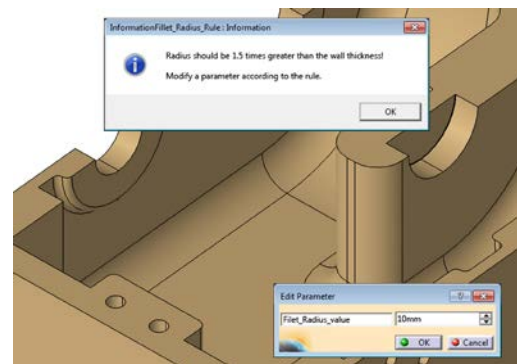

Fig. 5: Knowledgeware gives advice on the basis of previously defined rule.

Knowledge based technologies enable a user to define object-oriented product model and to include material characteristics, technological process requirement, standards and rules necessary for rule based design. It is important to note that these rules are not unchangeable, but can be customized to a user.

If we use relational dependency to connect, for example, rib thickness with the wall thickness and set the requirement using if/then relations to emphasize that the rib thickness has to be equal to the wall thickness, we get manufacturing restriction that a designer will use as an advice during product designing (Tab. 2).

Previously stated rule, along with some other rules, were described in table 2 where manufacturability evaluation of each rule was also described. In addition, adequate



advices were given in order to help designer during the continuation of product development.

Tab. 2: Part manufacturability evaluation and advice.

Part attribute / feature	Manufacturability evaluation and advice
Weight: 4.12 kg	Is within limits of process.
Maximum wall thickness: 30mm	Maximum wall thickness should be reduced below 6.3 mm.
Number of side-cores: = 4	Number of side-cores required is high and should be reduced.
Rib with = 8mm	Thickness of the rib is high and should be made equal to wall thickness.
Sharp edges	Sharp edges in the part should be rounded or smoothed.

Nowadays, different methods [20] are developed for assessing manufacturability of parts created during die-casting process.

## 5. CONCLUSION

Specificities of die casting processes and the available resources have to be taken into consideration during manufacturability analysis and presented to the designer in the form of either on-line or off-line advices, depending on the chosen process chosen. Previously presented on-line process is parametrically modeled part with inserted rules according to the if/then relations. The advice designer gets is the result of the set of experiential rules (examples of good practices) inserted during previous phrases of project design. Advice received aims at final product being produced more easily, distributed more cheaply, at the same time following the product life-cycle.

In general, working with knowledgware systems provides control and monitoring reduction during designing process and unites product development phases raising a concurrent engineering to a higher level, which is extremely important in terms of manufacturability.

## ACKNOWLEDGEMENT

This research is sponsored by the Ministry of Science and Technology of the Republic of Serbia - project id III 41017 for the period of 2011-2014.

## REFERENCES

[1] MADAN, J., RAO, P.V.M., KUNDRA, T.K. (2007) *Computer Aided Manufacturability Analysis of Die-cast Parts*, Computer-Aided Design & Applications, Vol.4, Nos. 1-4, pp 147-158.

[2] BOOTHROYD, G., DEWHURST, P., KNIGHT, W., (1994) *Product Design for Manufacture and Assembly*, Marcel Dekker Inc., New York.

[3] VAN VLIET, J. W., VAN LUTTERVELT, C. A., KALS, H. J. J., (1999) *State of the art report on design for manufacturing*, Proceedings of ASME DETC, September 12-15, Las Vegas.

[4] GUPTA, S. K., DAS, D., REGLI, W. C., NAU, D. S., (1997) *Automated manufacturability analysis: A survey*, Research in Engineering Design, 9(3), pp 168-190.

[5] SHAH, J. J., WRIGHT, P. K., (2000) *Developing theoretical foundations of DFM*, DETC2000/DFM 14015, September 10- 14, Baltimore, MD.

[6] SRIKUMARAN, S., SIVALOGANATHAN, S., (2005) *Proving manufacturability at the design stage using commercial modeling software*, Computer-Aided Design and Applications, 2 (1-4), 507-516.

[7] RAMANA, K. V., RAO, P. V. M., (2005) *Automated manufacturability evaluation system for sheet metal components in mass production*, International Journal of Production Research, 43 (18), pp 3889–3913.

[8] ZHAO, Z., SHAH, J. J., (2005) *Domain independent shell for DFM and its application to sheet metal forming and injection molding*, Computer-Aided Design, 37, pp 881–898.

[9] SONG, I. –H., PARK, J. –M, CHUNG, S. –C, (2005) *Web based interference verification system for injection mold design*, Computer-Aided Design and Applications, 3 (1-4), pp 129-138.

[10] NI, Q., LU, W. F., YARLAGADDA, P.K.D.V., (2006) *A PDM-based framework for Design to Manufacturing in mold making industry*, Computer-Aided Design & Applications, Vol. 3 Nos. 1-4, pp 211-220.

[11] MANIĆ, M., MILTENOVIĆ, V., STOJKOVIĆ, M., BANIĆ, M., *Feature Models in Virtual Product Development*, Strojniški vestnik - Journal of Mechanical Engineering 56(2010)3.

[12] SHUKOR, S.A., AXINTE D.A. (2009) *Manufacturability analysis system: issues and future trends*, International Journal of Production Research, Vol. 47, No. 5, pp 1369-1390.

[13] MANIĆ, M., MILTENOVIĆ, V., STOJKOVIĆ, M., *Feature Models in Virtual Product Development*, The scientific journal FACTA UNIVERSITATES, Ser. Mechanical Engineering, Vol. 1, No 10, p.p. 1327-1337, 2003, 2003.

[14] STOJKOVIĆ, M. (2010), *Analysis of the Manufacturability Parameters Based on Semantic Structures of the Digital Product Model*, Doctoral dissertation, Faculty of Mechanical Engineering, Niš.

[15] HUI, K. C., (1997) *Geometric aspects of the mouldability of parts*, Computer aided design, 29 (3), pp 197-208.

[16] BRALLA, J.G. (1999) *Design for Manufacturability Handbook*, McGraw Hill, New York.

[17] (1998) *Product Design for Die Casting*, North American Die Casting Association (NADCA), Rosemont, USA.

[18] MADAN, J., RAO, P. V. M., KUNDRA, T. K. (2006) *An automated cost estimation system for die-cast parts*, Transactions of ASME Journal of Computing and Information Science in Engineering.

[19] STOJKOVIC, M., MANIC, M., TRAJANOVIC, M. (2005) *Knowledge-Embedded Template Concept*, CIRP Journal of Manufacturing Systems, Vol.34 No1.

[20] BIDKAR, R. A., McADAMS, D. A. (2010) *Methods for automated manufacturability analysis of injection-molded and die-cast parts*, Research in Engineering Design, Vol. 21, No. 1, pp 1-24.